

x 14

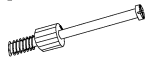

x 14

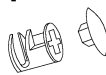

x 16

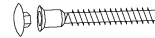

(a)

(b)

(c)

x 4 (400 mm - kpl.)

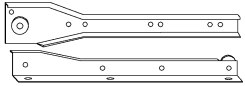

x 3

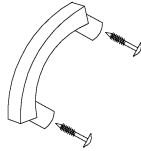

x 36

(3,5x30)



(d)

(e)

(f)

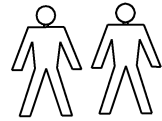

40 min



x 46

(3,5x16)



x 6

(ø6x18x2)



x 6



(g)

(h)

(i)

x 30

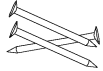

x 1

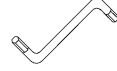

(j)

(k)

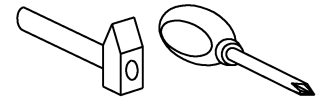

① - FAZY MONTAŻU

Ⓐ - OZNACZENIE ELEMENTÓW

Ⓐ - OZNACZENIE AKCESORIÓW

①

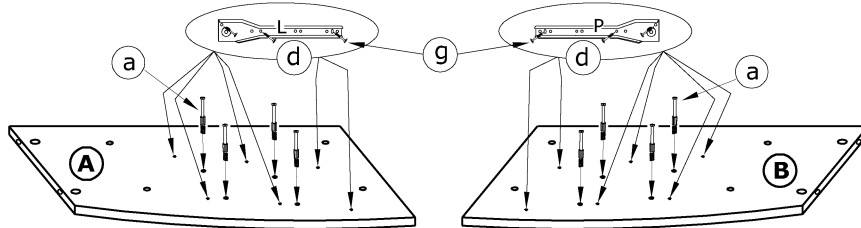

②

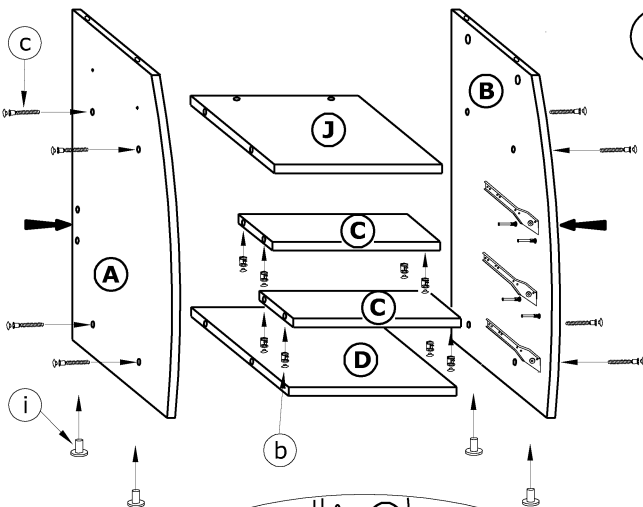

③

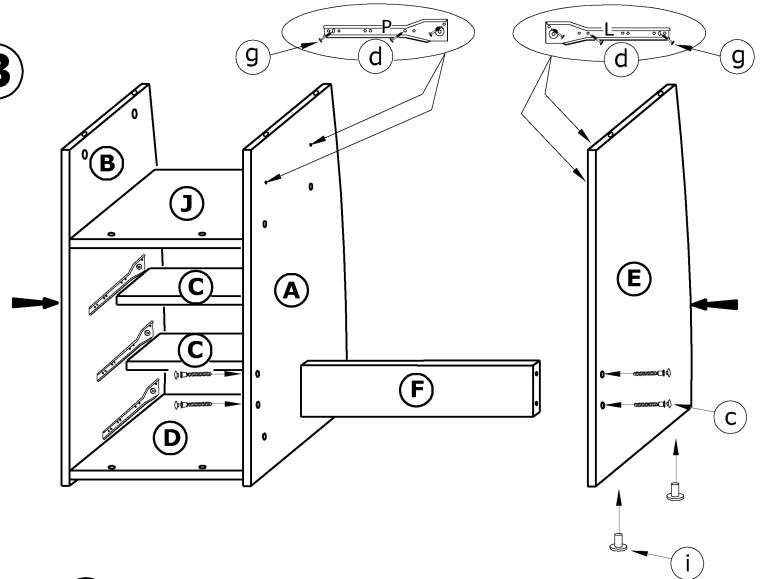

④

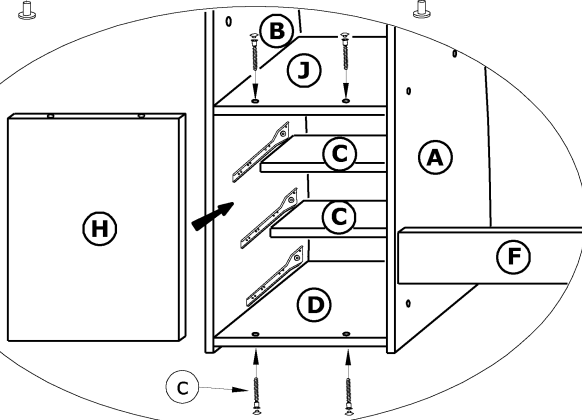

⑤

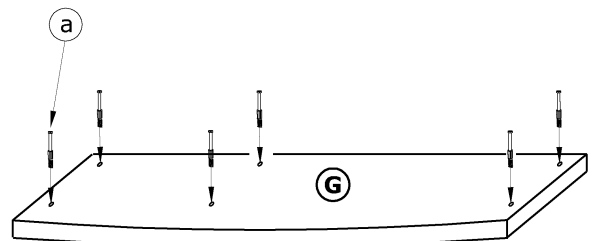

6

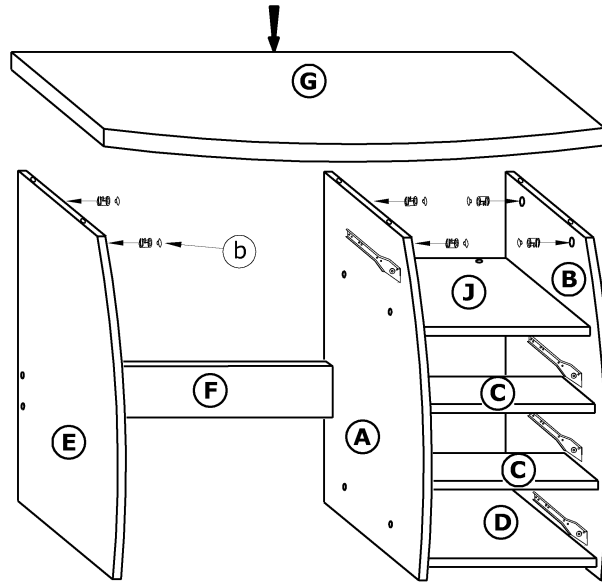

3X

7

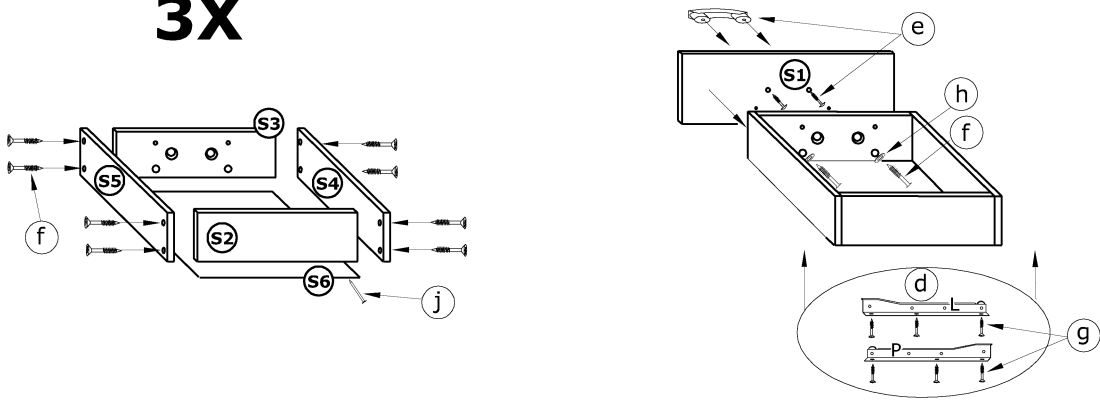

8

