

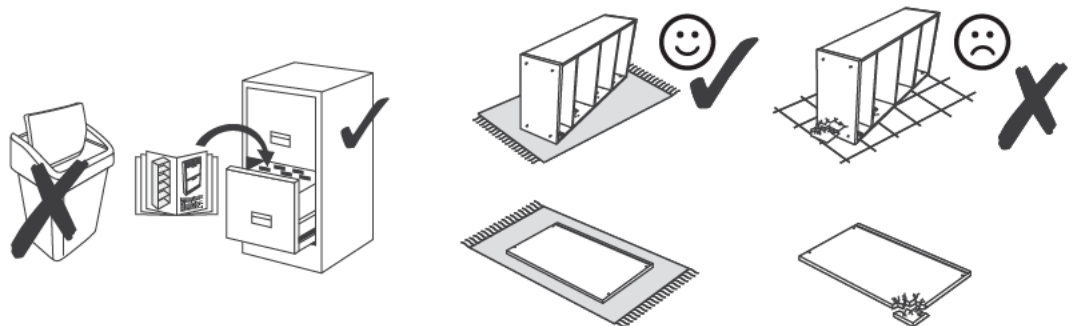

Modell **BL14**

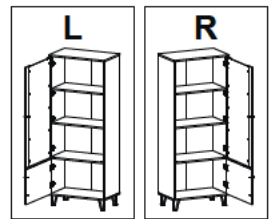

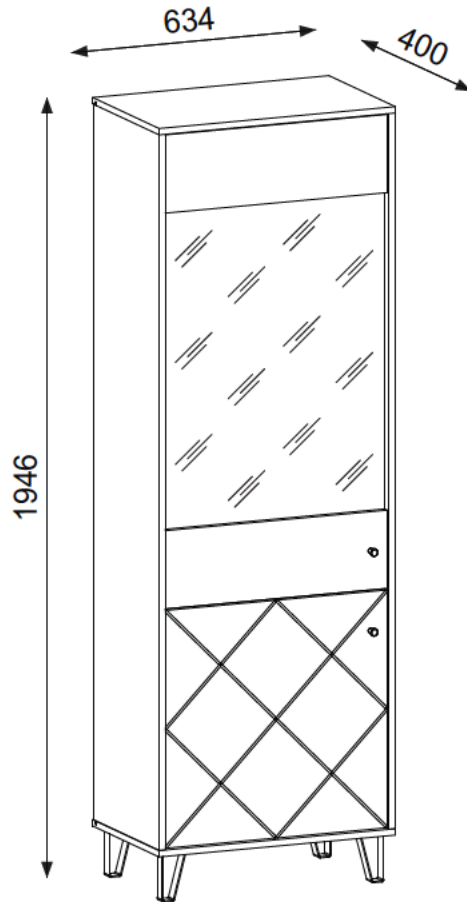

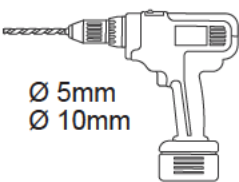
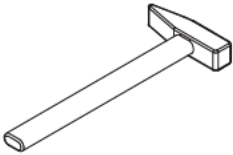
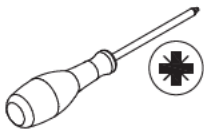
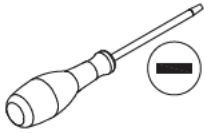
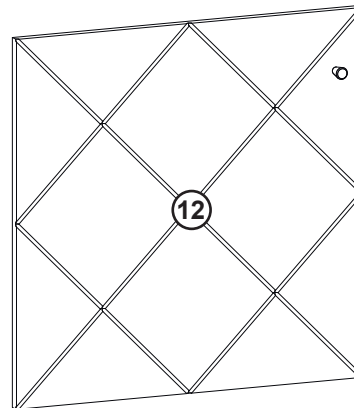
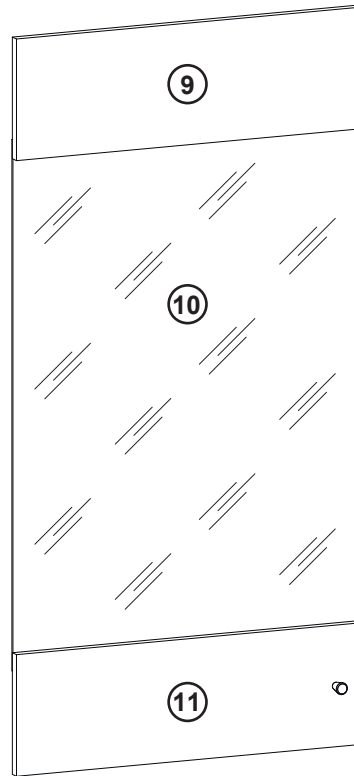
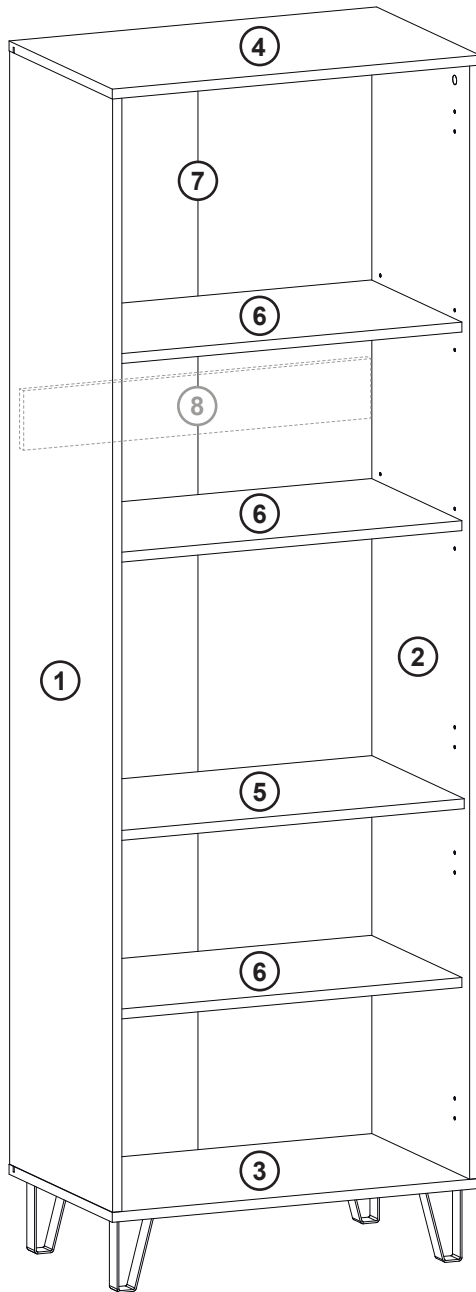
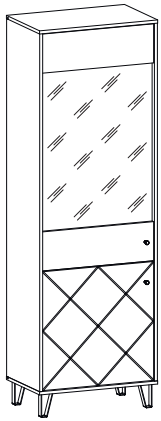

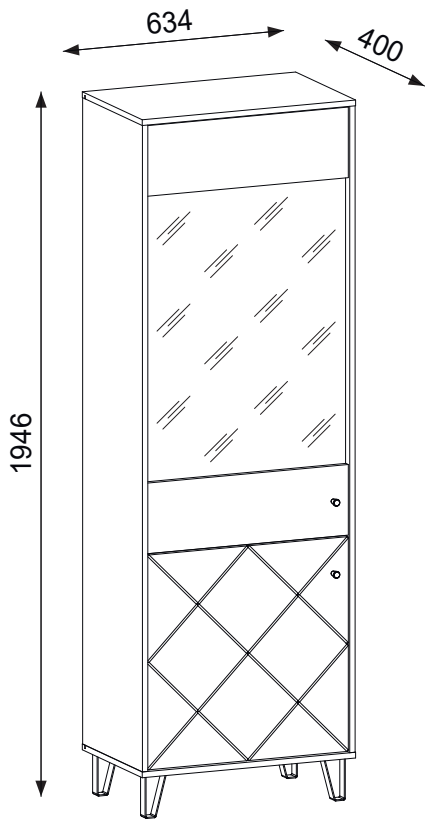

A	B (mm)			C	D
1	1794	399	16	x1	2/2
2	1794	399	16	x1	2/2
3	634	400	16	x1	2/2
4	634	400	16	x1	2/2
5	600	358	16	x1	1/2
6	599	350	16	x3	1/2
7	1808	614	2.5	x1	2/2
8	600	96	16	x1	1/2
9	596	196	16	x1	2/2
10	856	594	4	x1	1/2
11	596	196	16	x1	2/2
12	596	596	16	x1	1/2

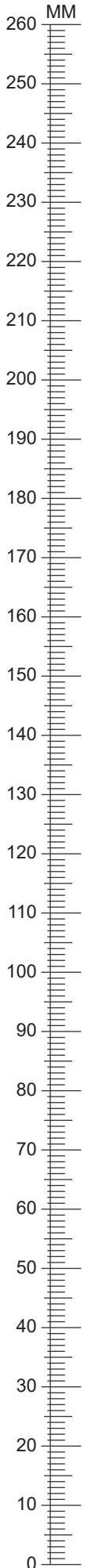

1x	
	L=75x25x15mm n14/2
1x	
	Ø 8x50mm y1
1x	
	Ø 5x50mm p60

1x		4x		16x	
4mm	z1	Ø 6,3x50mm	e27	Ø 8x30mm	f1
10x		10x		8x	
45mm	r23	Ø 15x12mm	r1	Ø 20mm	s1
4x		4x		16x	
Ø 35mm	ab4	h=120mm	k48	10x10x15mm	l2
12x		1x		2x	
Ø 5mm	d1	Ø 5mm	d2	25x19x19mm	k1
3x		2x		8x	
Ø 4,2x16mm	p21	Ø 4x27mm	p28	Ø 4,2x19mm	p29
8x		2x		8x	
10x6x10mm	d6	Ø 3x16mm	p50	Ø 3,5x16mm	p51



1	f1 x 16  Ø 8x30mm	r1 x 10  Ø 15x12mm	r23 x 10  45mm	d1 x 12  Ø 5mm
----------	---	--	--	--

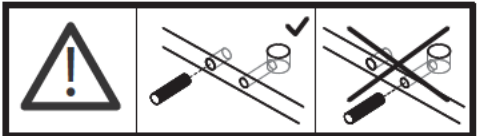
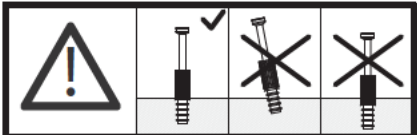
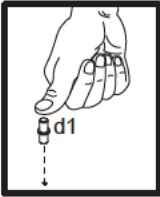
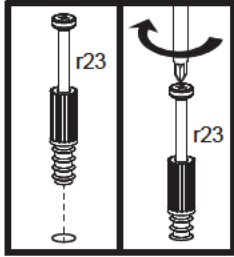
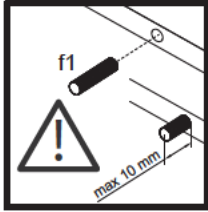
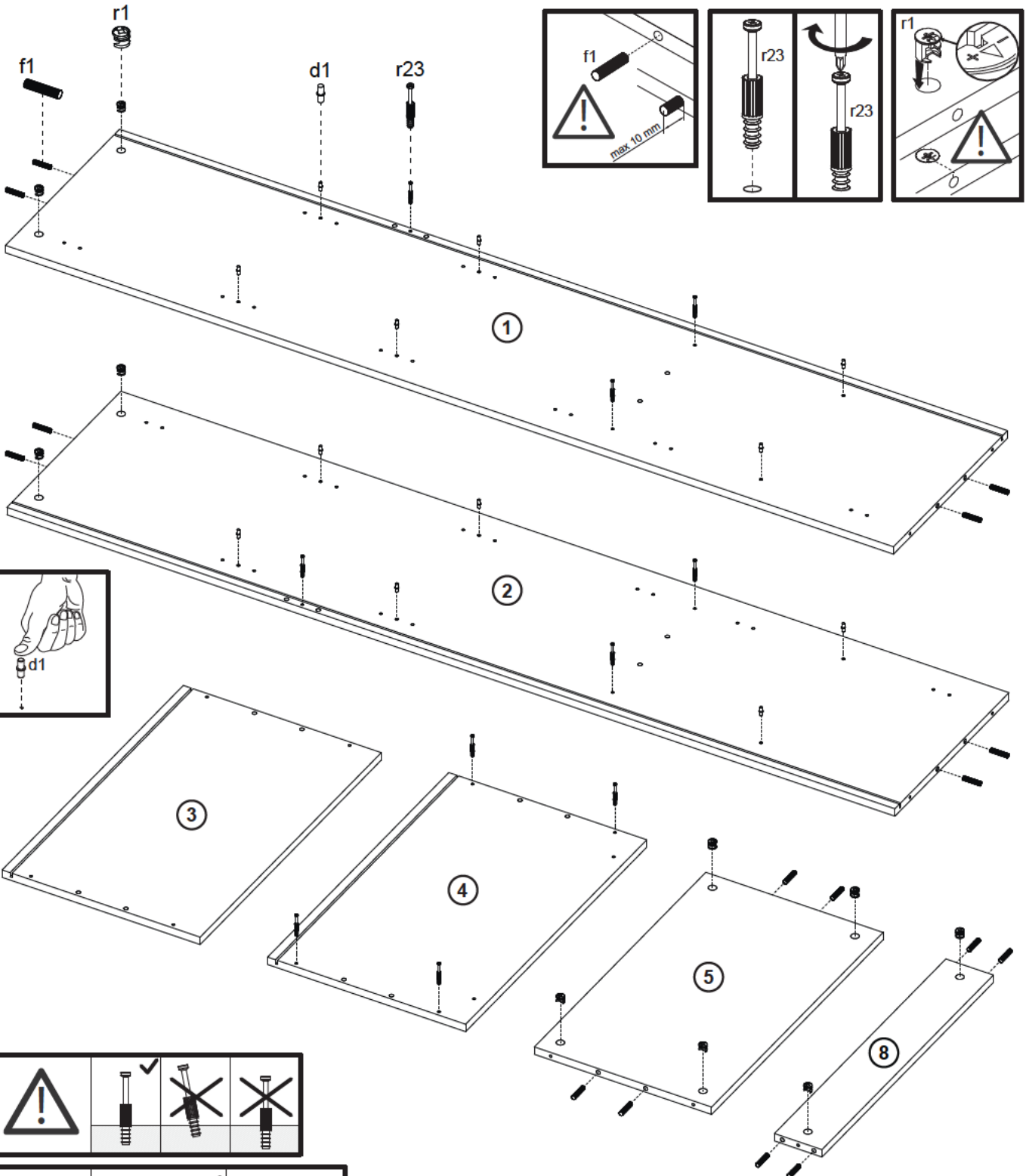

2	s1 x 4
	Ø 20mm

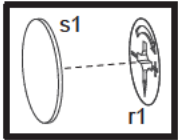
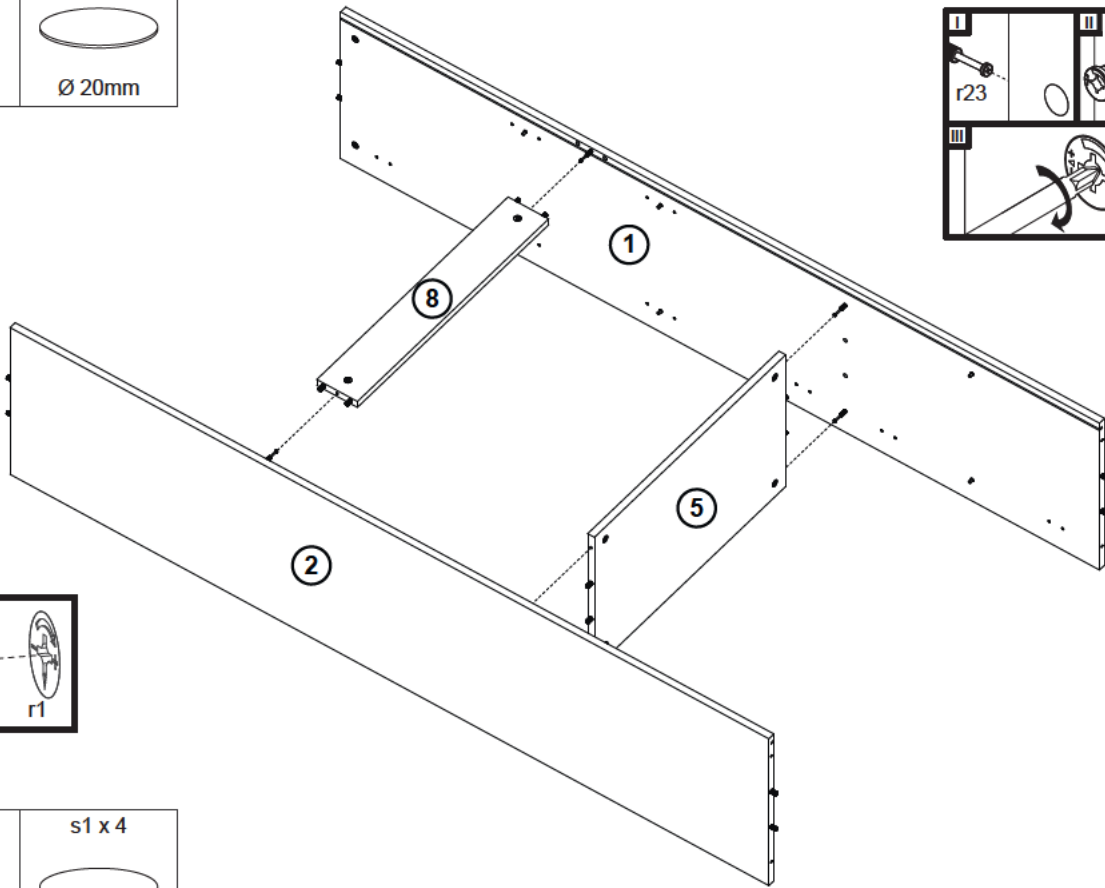
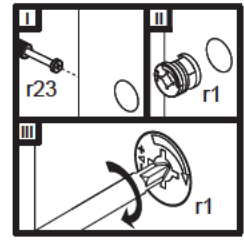

3	s1 x 4
	Ø 20mm

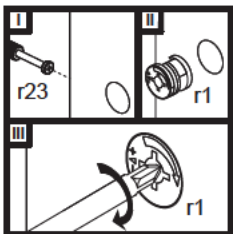
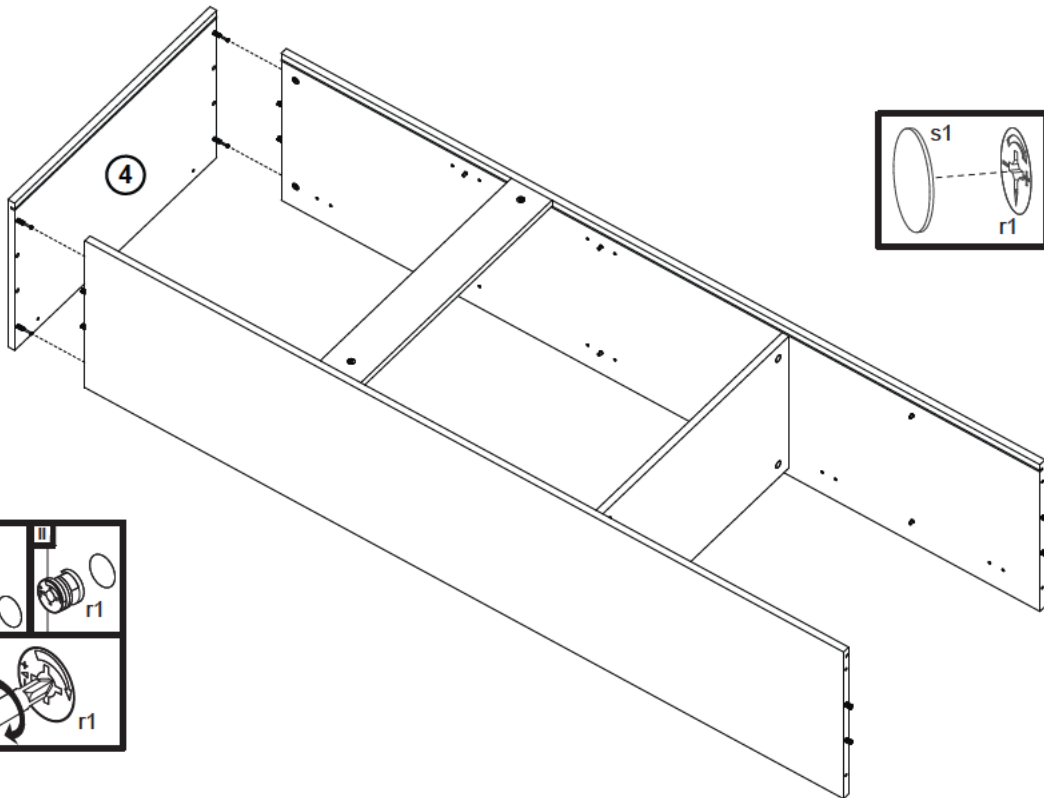
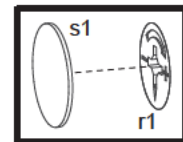

4

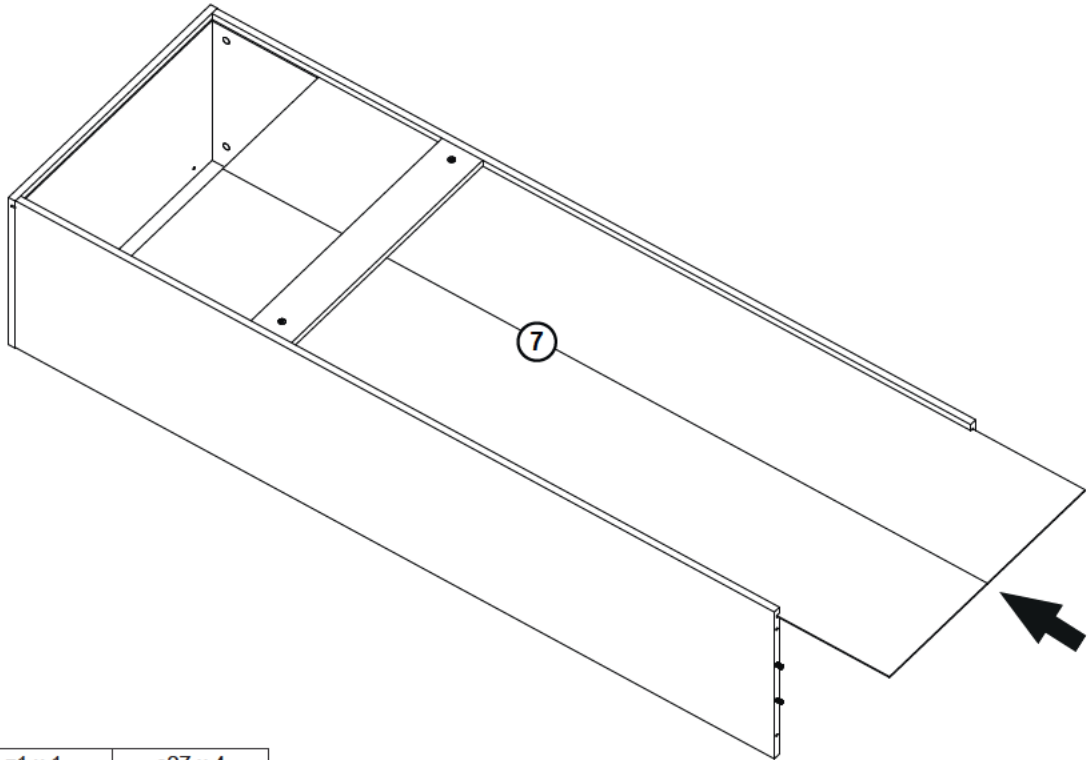

5

z1 x 1



4mm

e27 x 4



Ø 6,3x50mm

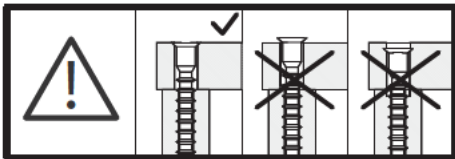
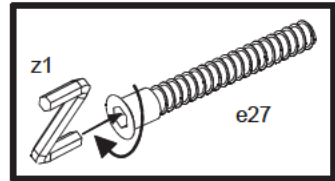
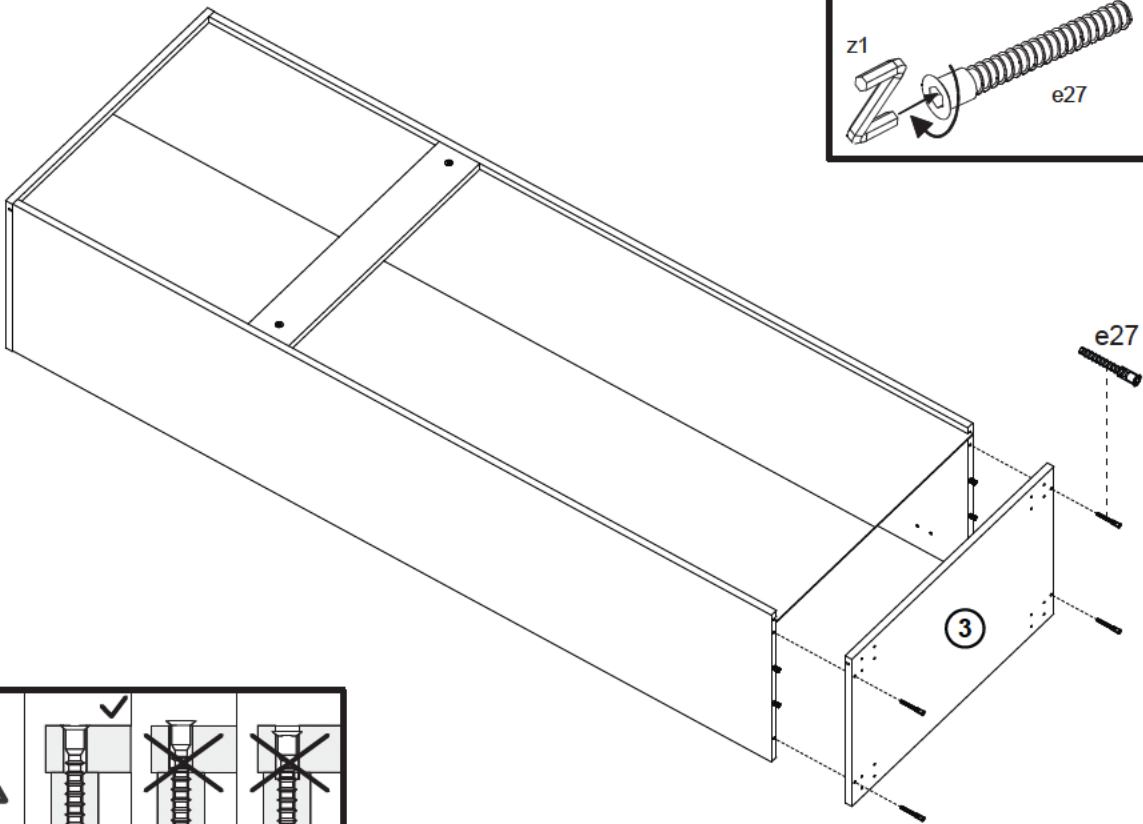

6

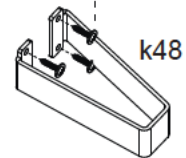
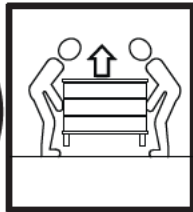
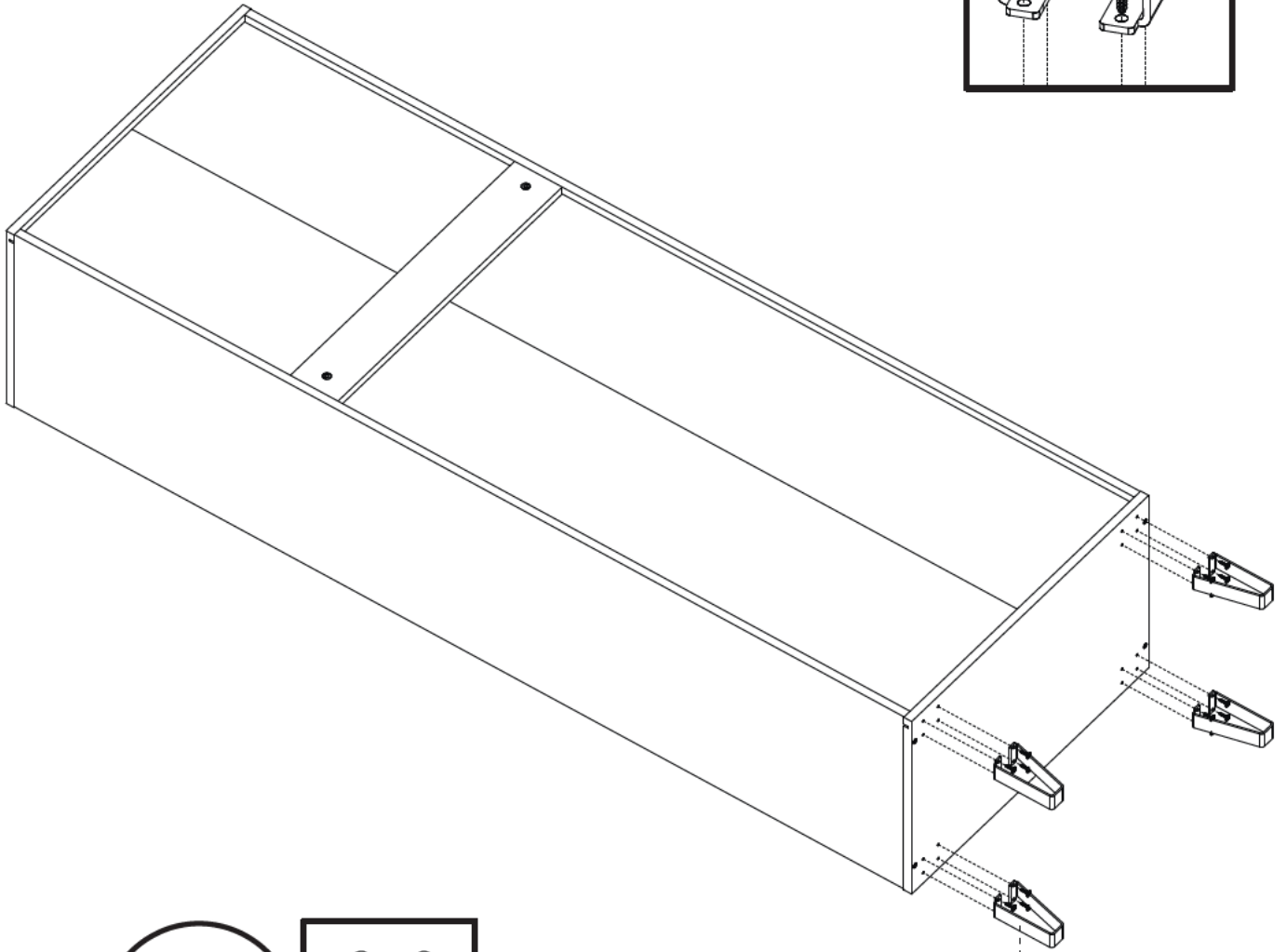
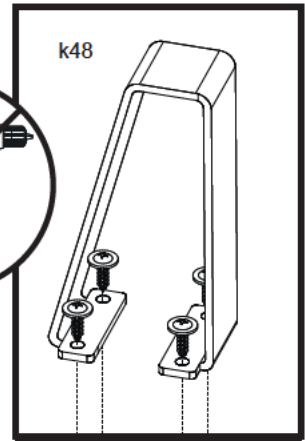
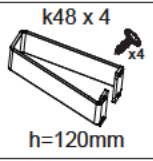

7

p21 x 3



Ø 4,2x16mm

I2 x 16



10x10x15mm

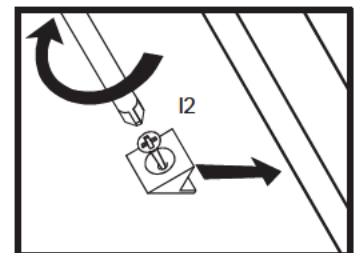
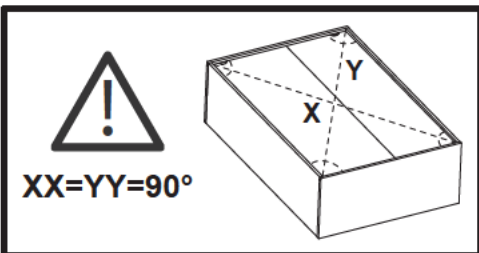
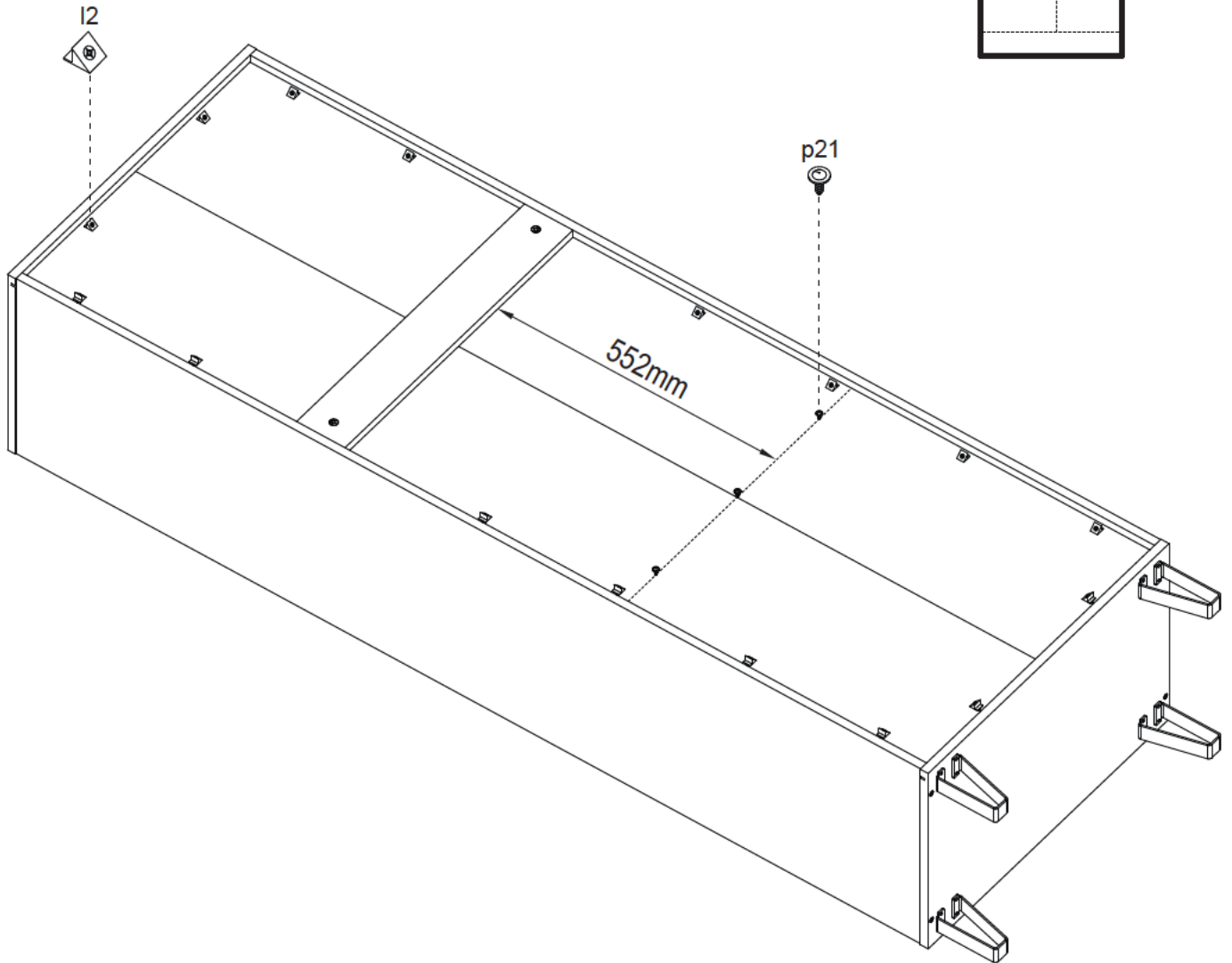
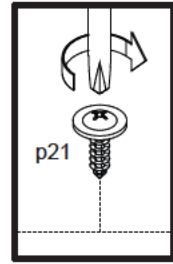

8

p50 x 2



Ø 3x16mm

n14/2 x 1



L=75x25x15mm

p60 x 1







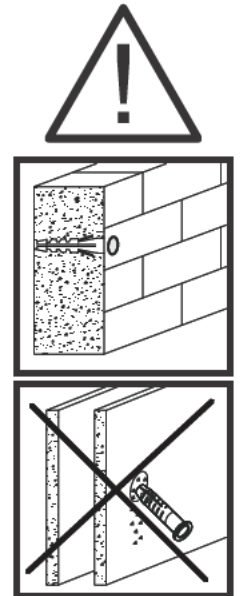
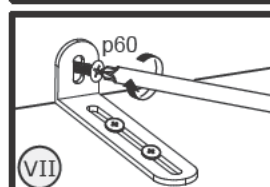
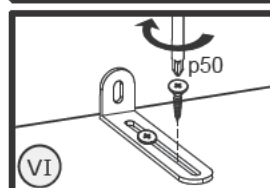
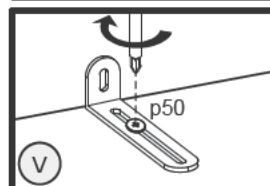
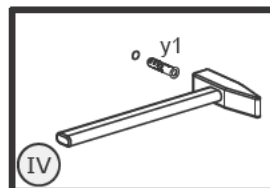
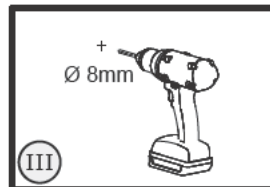
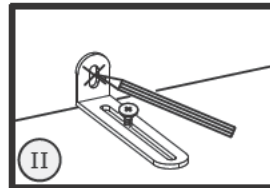
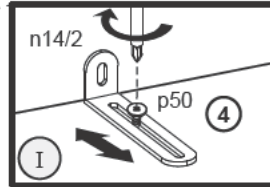
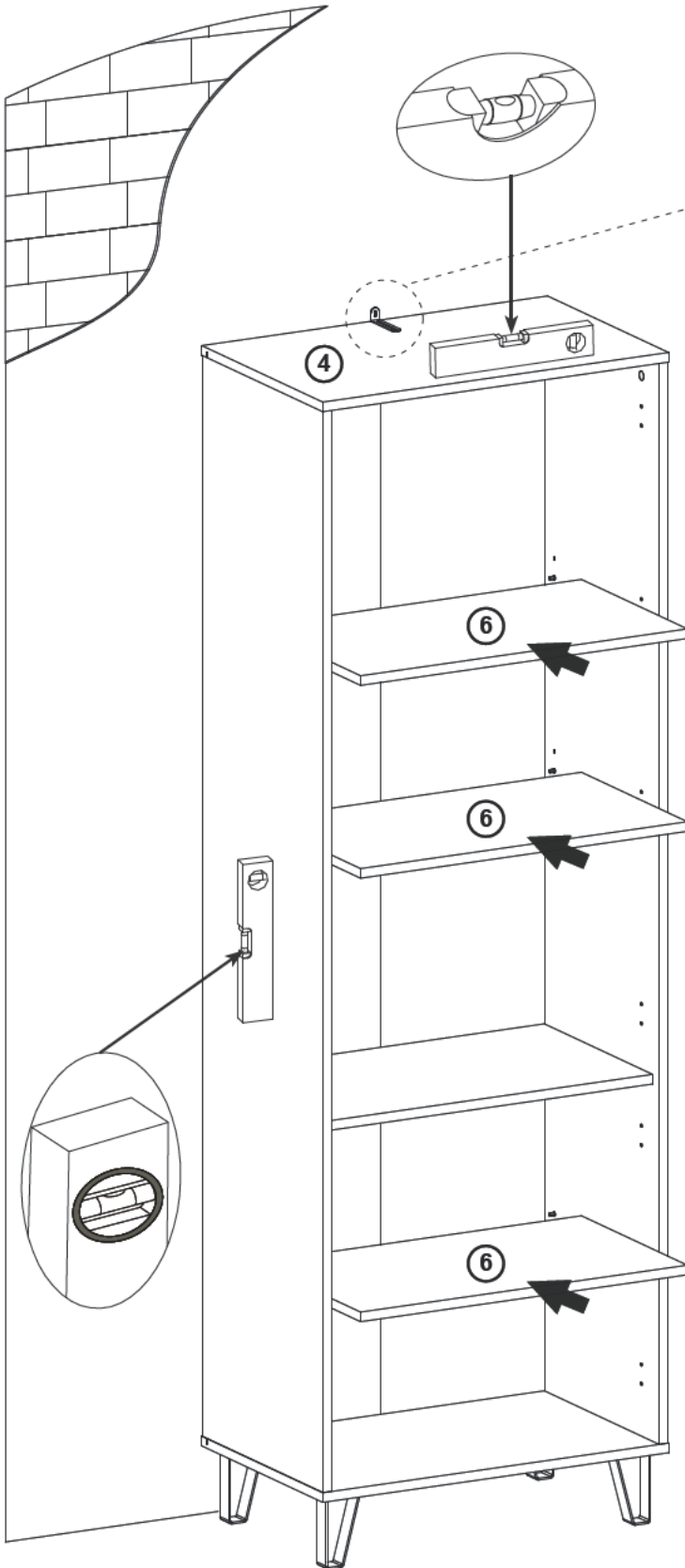

Ø 5x50mm

y1 x 1



Ø 8x50mm



9	ab4 x 4	p51 x 8	k1 x 2	p28 x 2	d6 x 8	p29 x 8
	 Ø 35mm	 Ø 3,5x16mm	 25x19x19mm	 Ø 4x27mm	 10x6x10mm	 Ø 4,2x19mm

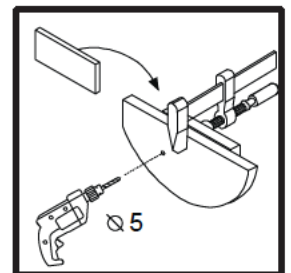
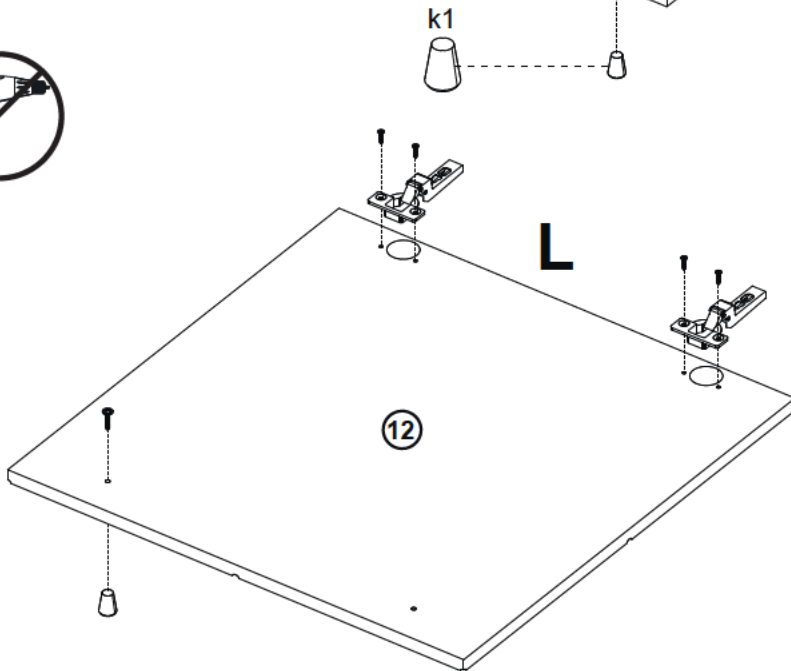
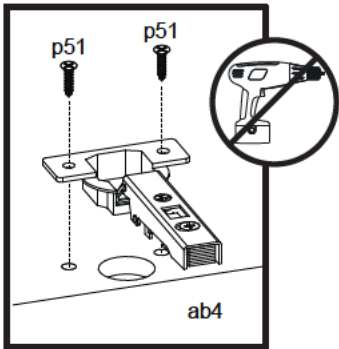
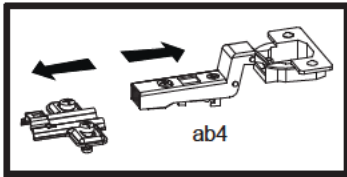
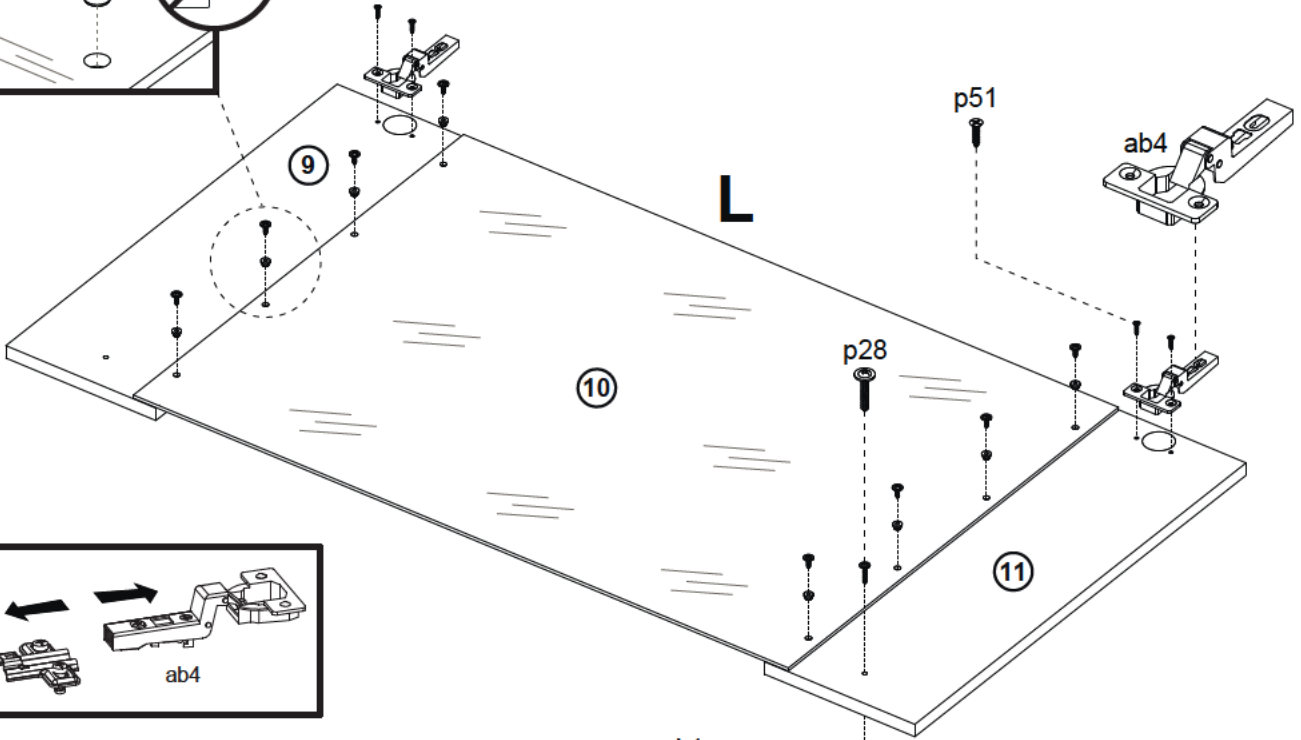
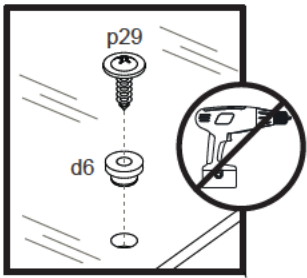

10

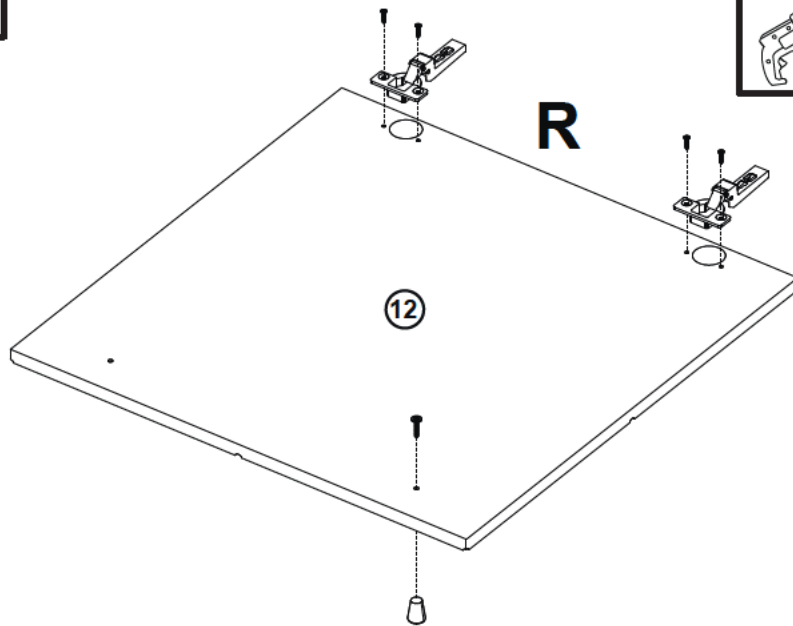
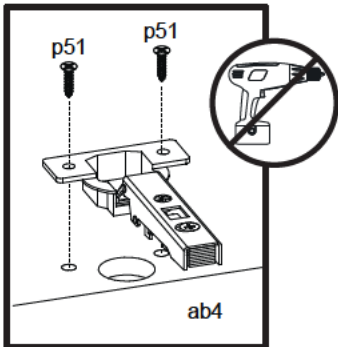
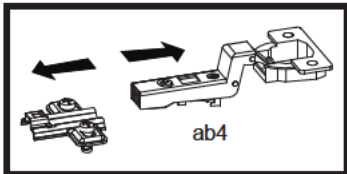
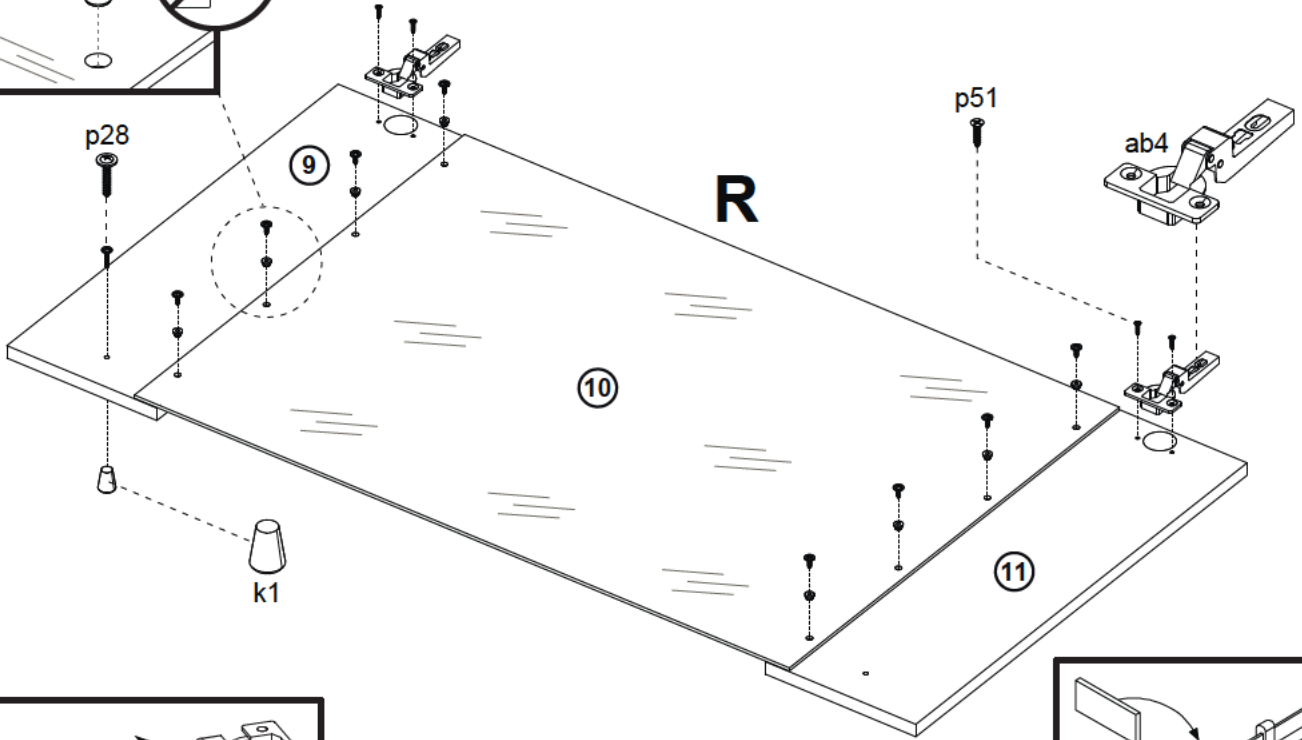
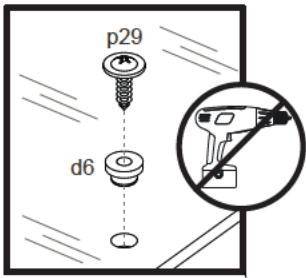
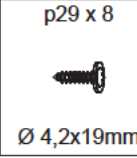
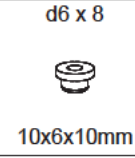
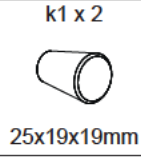
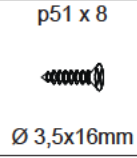
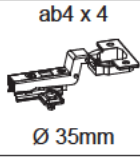

11

ab4 x 4



Ø 35mm

d2 x 1



Ø 5mm

L

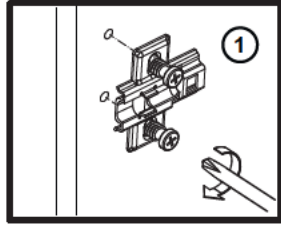

R

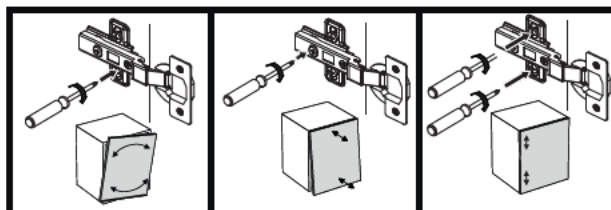
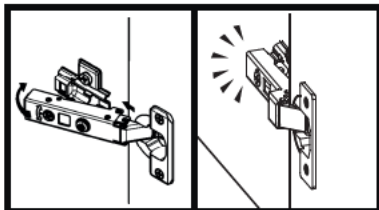
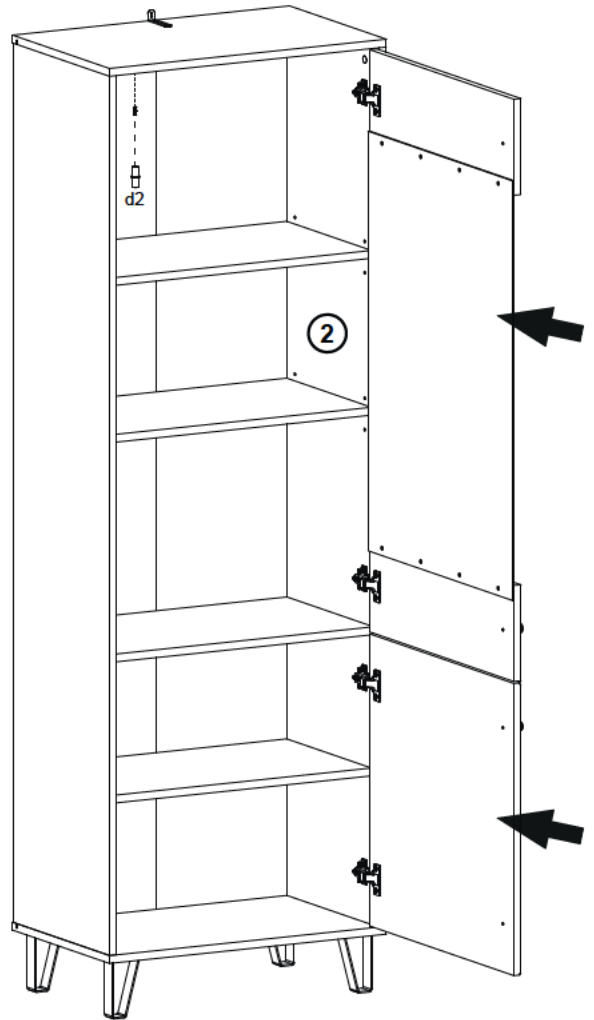
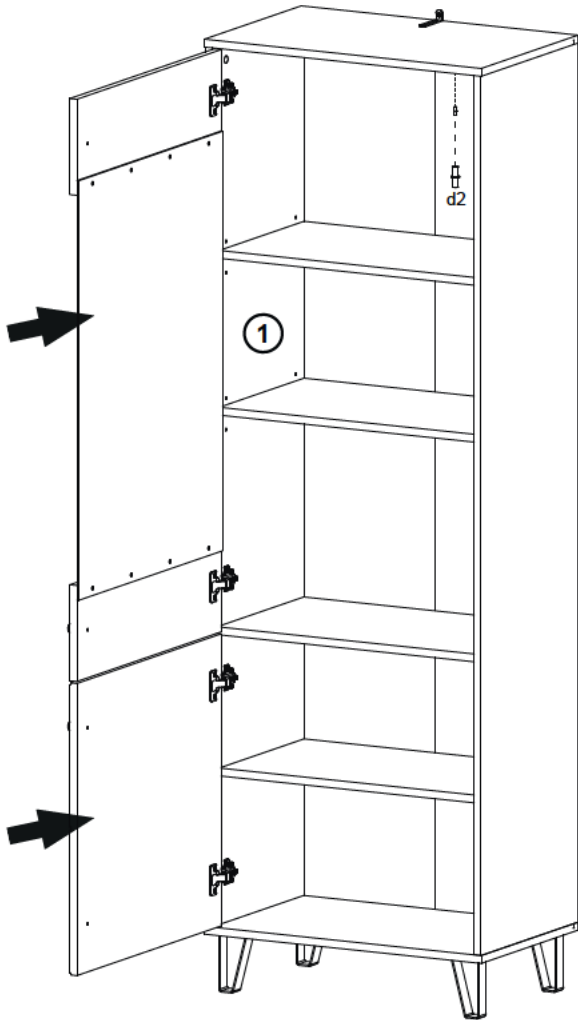
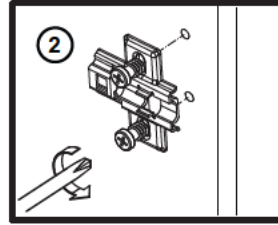

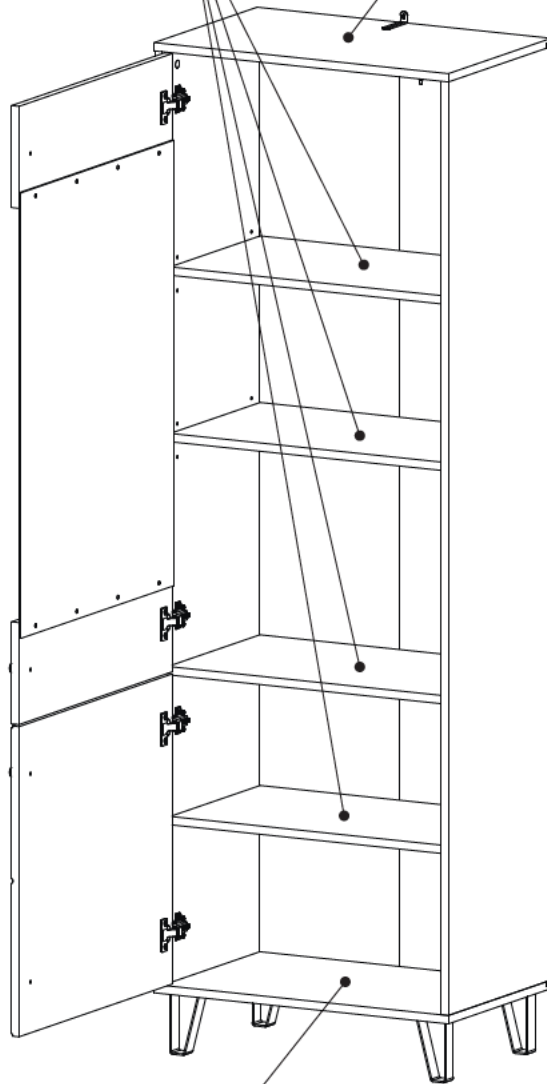

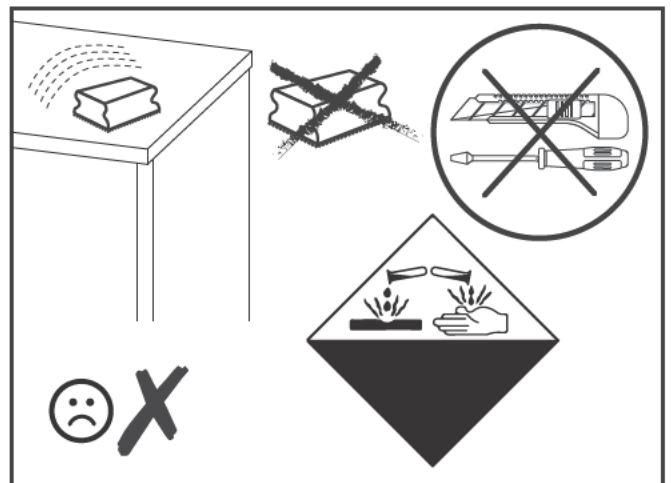
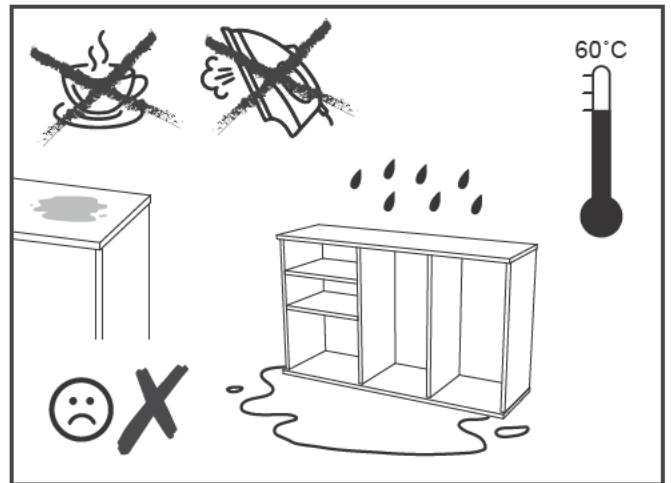
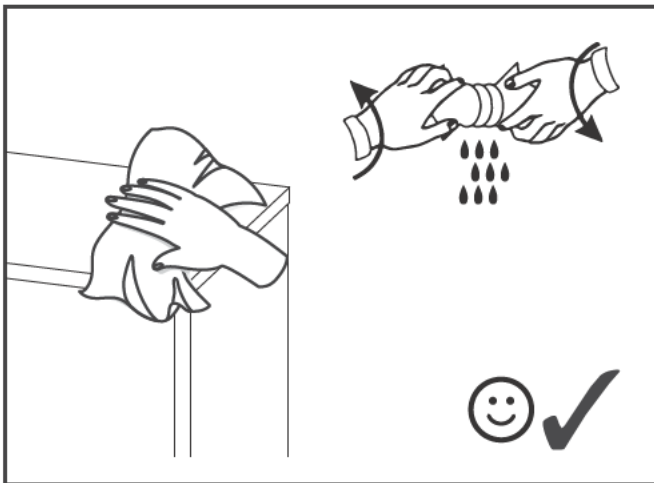
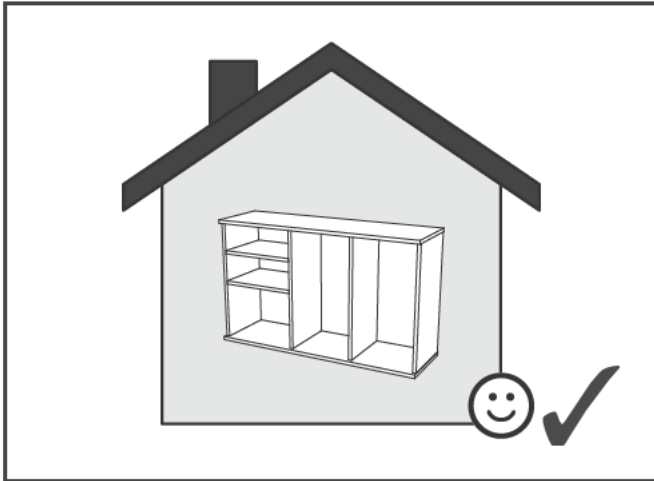

- PL** Powierzchnię mebli należy czyścić tylko środkami do pielęgnacji mebli. Szanowny kliencie w przypadku reklamacji prosimy wypełnić druki reklamacyjne dostępne w punktach sprzedaży przedkładając Kartę Reklamacyjną (zawierającą datę produkcji i numer pakowacza lub zmiany pakowania) umieszczona w każdej z paczek, oraz instrukcję montażu mebla, gdzie prosimy o zaznaczenie uszkodzonego elementu.
- SK** Povrch nábytku čistite iba prostriedkami určenými na ošetrovanie nábytku.Vá ení zákazníci! V prípade reklamácie prosíme, aby ste vyplnili tlačivá, ktoré sú prístupné v obchodoch, predlo ili Reklamačný list (ktorý obsahuje dátum výroby a číslo baliča alebo číslo zmeny pri balení), ktorý sa nachádza v ka dom balení a návod na montá nábytku, v ktorom označte poškodenú čas.
- CZ** Povrch nábytku čistěte pouze přípravky určenými k ošetřování nábytku.Vá ený zákazník, v případě uplatnění reklamace vyplňte prosím reklamační formuláře, které jsou dostupné v prodejnách a předlo te Reklamační kartu (obsahující datum výroby a číslo balení nebo změny balení, která je umístěna v balíčku) a návod k obsluze s vyznačením poškozeného dílu.
- BG** Повърхността на мебелите трябва да се почиства само с препарати за поддържане на мебели.Уважаеми клиенти, в случай на рекламация моля попълнете формулярите за рекламация, които ще получите в търговските пунктове, като представите Картата за рекламация (съдържаща датата на производство и номера на опаковчика или смяната за опаковане), която ще намерите във всяка опаковка, и инструкцията за монтаж на мебела, върху която да отбележите повредения елемент.
- RO** Suprafața ei trebuie să fie curățată numai cu substanțe destinate pentru curățarea mobilei.Stimate Cumpărător, în caz de reclamație vă rugăm să completați formularul de reclamație pe care îl puteți lua de la punctul de vânzare și pe care îl veți prezenta împreună cu Cartela de Garanție (care conține data producției și nr ambalatorului sau turei de ambalare), însoțită la fiecare ambalaj, precum și instrucțiunile de montaj ale mobilei, pe care vă rugăm să marcați elementul deteriorat.
- UA** Поверхню меблів потрібно чистити тільки засобами для догляду за меблями.Шановний клієнте для заяви рекламачії, просимо заповнити формуляр рекламачії, доступний у пунктах продажу, вказуючи рекламачійну карту (містить дату виробництва та номер пакувальника або зміни упаковки), прикладену до кожного пакету, а також інструкцію з монтажу меблів, на якій просимо позначити пошкоджений елемент.
- RUS** Поверхность мебели надо чистить только средствами для ухода за мебелью.Уважаемый клиент для заявления рекламации, просим заполнить формуляр рекламации, доступный в пунктах продажи, указывая Рекламационную карту (содержащую дату производства и номер упаковщика или смены упаковки), приложенную к каждому пакету, а также инструкцию по монтажу мебели, на которой просим обозначить поврежденный элемент.
- DE** Reinigen Sie den Möbelbereich nur mit Möbelpflege. Kunden, bei Beanstandung Bitte füllen Sie die Reklamationsformulare, die in den Verkaufsabteilungen erhältlich sind, vor dem Verkauf aus eine Reklamationskarte (mit Angabe des Produktionsdatums und der Anzahl der Personen, die die Waren verpacken, oder der Anzahl der Schichten)Verpackung), die in jeder Packung enthlten ist, und Halterungen, in denen Sie reichlich vorhanden oder beschädigt sind ElementeReinigen Sie den Möbelbereich nur mit Möbelpflege. Kunden, bei Beanstandung.
- GB** Furniture surface must be cleaned only with furniture maintenance formulas.Dear Customer, should you wish to file a complaint, we would request you to fill in the complaint forms available in our outlets, submitting the Complaint Card (specifying the date manufactured, packaging employee/ shift code) enclosed in each of the packets, together with the Assembly Manual, where please highlight the faulty component.
- H** A bútorok felületét kizárólag a bútorápolószerekkel lehet tisztítani. Tisztelt Vásárló! Reklamáció esetén kérjük az eladási helyeken kapható reklamációs nyomtatványokat kitölteni a Reklamációs Lap (tartalmazza a gyártási dátumát és csomagoló számát vagy műszakszámát) bemutatásával, amely mindegyik csomagban található, valamint a bútor szerelési utasítását, amelyen kérjük a sérült elemet bejelölni sziveskedjék.
- FR** La surface des meubles ne peut être nettoyée qu'avec des produits pour l'entretien de meubles. Cher Client, en cas de réclamation, veuillez bien remplir des formulaires de réclamation accessibles dans les centres de vente en montrant le mode d'emploi pour monter le meuble. Nous vous demandons de bien vouloir y entourer l'élément en panne.
- ES** Limpiar la superficie de muebles exclusivamente con los agentes para el cuidado de los muebles.Estimado Cliente, en caso de reclamaciones, hagan favor de rellenar los formularios de reclamación disponibles en los puntos de venta, presentando las instrucciones de montaje de mueble, donde es necesario indicar un elemento estropeado.