

ASSEMBLY INSTRUCTION

MANHATTAN GB II 5+5 CHEST

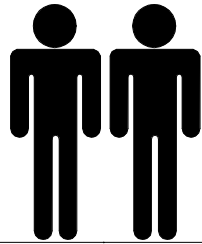

2 PERSON ASSEMBLY

FLOOR AREA
3.5M X 2.0M



CEILING HEIGHT
2.3M

(FLAT BULD)
REQUIRED ASSEMBLY SPACE

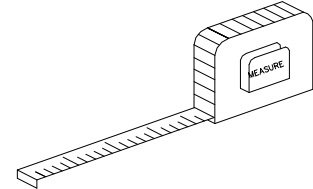
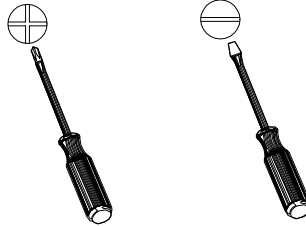

REQUIRED ASSEMBLY TOOLS

ASSEMBLED DIMENSIONS

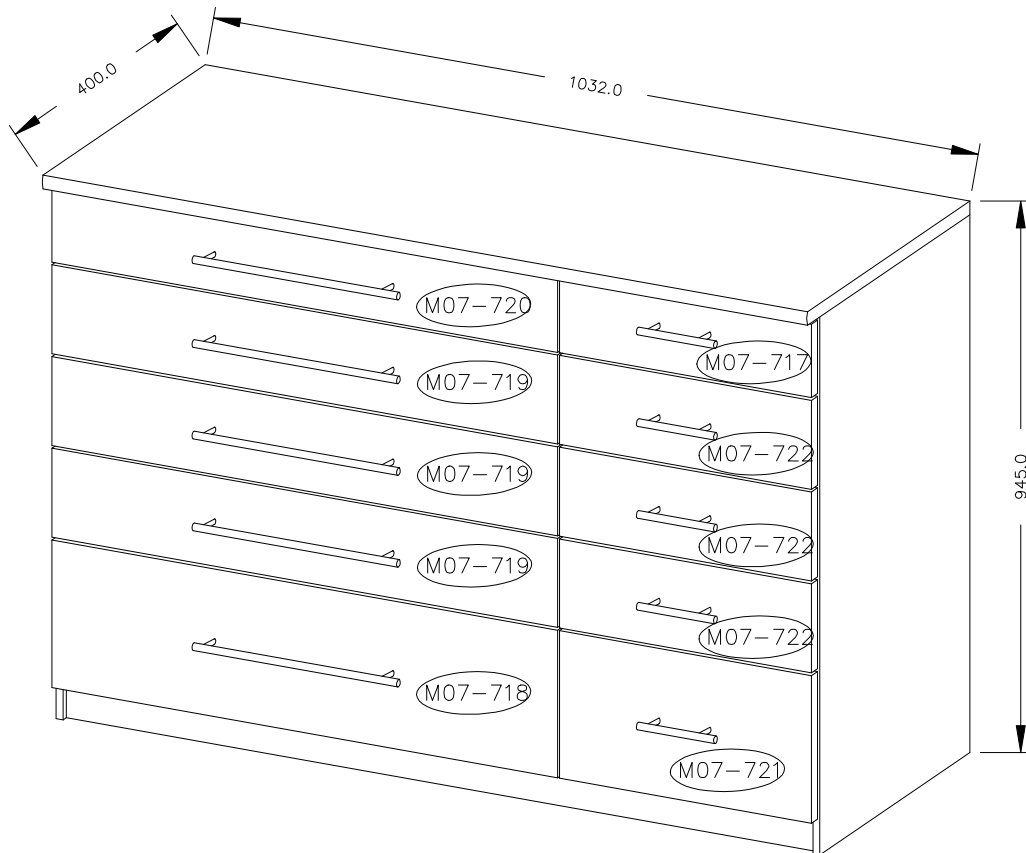

NO.	PART LIST	QTY
122	LEFT SIDE	1
123	RIGHT SIDE	1
2130	DASH PANEL	1
422	UPPER PANEL	1
423	BOTTOM PANEL	1
806	BATTEN OF PLINTH	2
351	JOINING SLAT	1
352	JOINING SLAT	1
717	DRAWER'S FRONT	1
718	DRAWER'S FRONT	3
719	DRAWER'S FRONT	1
720	DRAWER'S FRONT	1
721	DRAWER'S FRONT	3
722	DRAWER'S FRONT	1
9100	LEFT SIDE OF CARCASE	8
9110	RIGHT SIDE OF CARCASE	8
9130	LEFT SIDE OF CARCASE	2
9140	RIGHT SIDE OF CARCASE	2
962	BACK PANEL OF CARCASE	4
963	BACK PANEL OF CARCASE	4
968	BACK PANEL OF CARCASE	1
969	BACK PANEL OF CARCASE	1
052	BOTTOM OF DRAWER	5
053	BOTTOM OF DRAWER	5
014	BACK PANEL COMBINED WITH TAPE	1
015	BACK PANEL	1

PARTS LIST

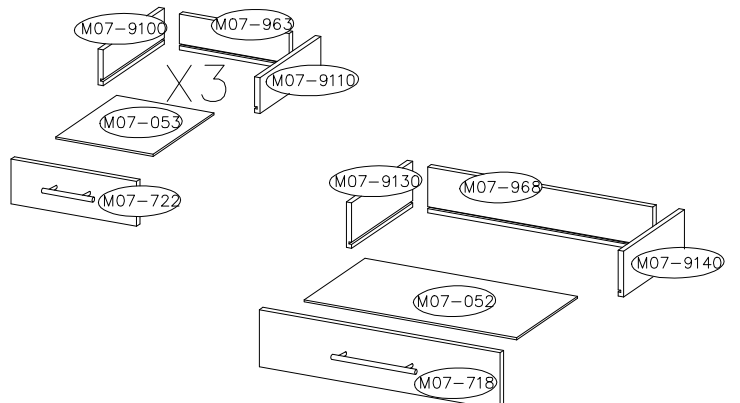
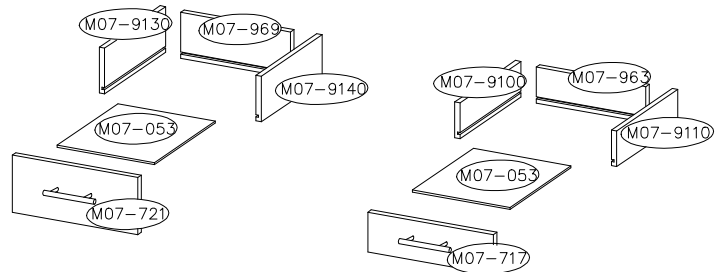
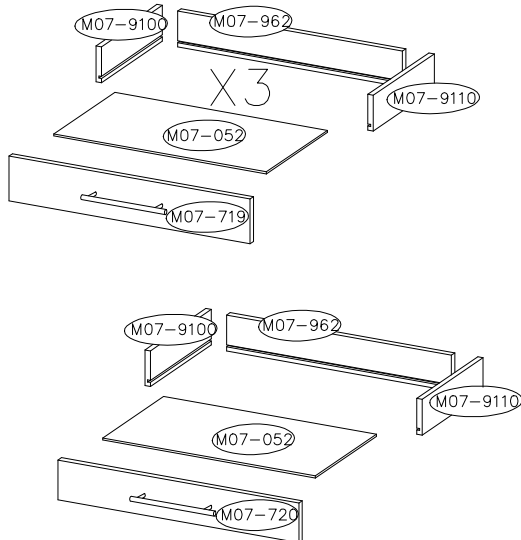
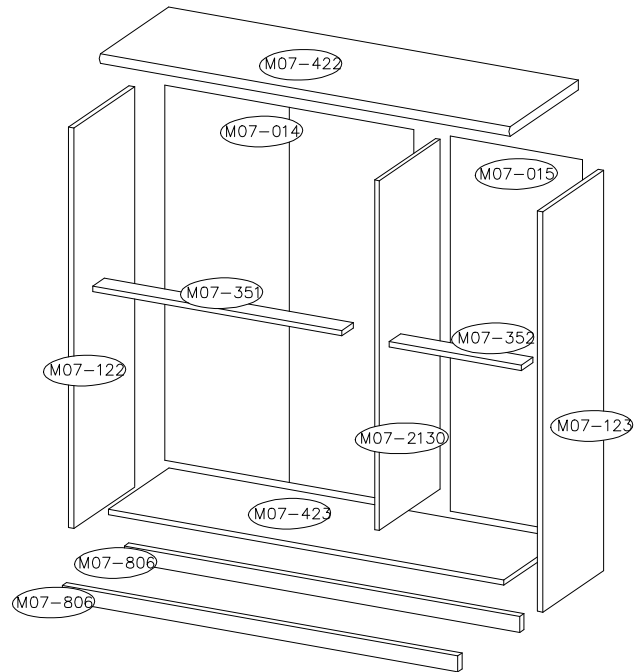





PACK 1 CONSISTS OF PARTS:



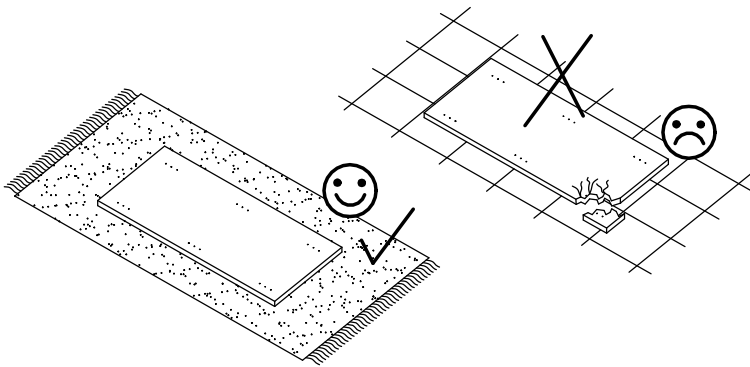
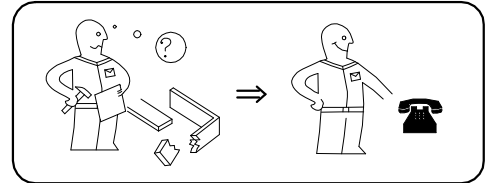
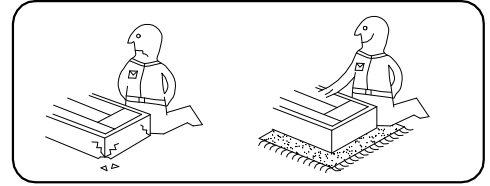
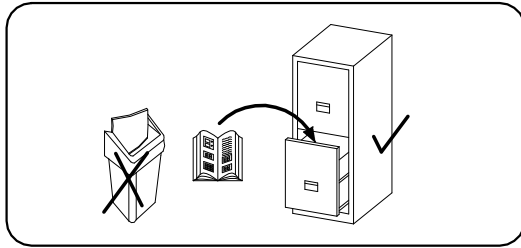



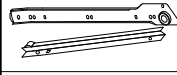



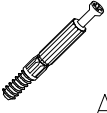



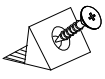
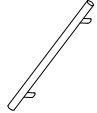
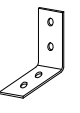

422, 423, 351, 352, 806, 717, 718, 719, 720,
721, 722, 962, 963, 968, 969, Al, Fittings

PACK 2 CONSISTS OF PARTS:

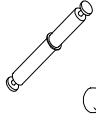
122, 123, 2130, 014, 015, 052, 053, 9100, 9110, 9130, 9140,

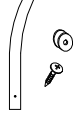

 C	 R
	 L
20	10 KPL

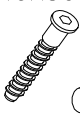
 A	 B	 D	 6.3X13 F	 M4.0X40 G	 I	 J	 U	 N	 3.5X13 S
34	36	60	20	20	1	10	5	4	16
 T3	 4.0X8 U6	 Q	 U1	 3mm K1	 I1	 J2	 3.0X10 M1	 3.0X15 P1	 5.0X50 Q1
10	20	1	5	1	1	5	10	60	44

Top Tips before you start!

1. Please check that all parts are present before you start the assembly of your furniture, as once assembled, the furniture is exempt from our home approval policy.
2. For ease and speed of assembly, we recommend that before you commence each step of the assembly, that you identify all the parts required for that step.
3. For larger items, please ensure that you have sufficient space and people (as indicated on page 1) to assemble your product safely.
4. We recommend that, where possible, all items are assembled near to the area in which they will be placed in use, to avoid moving the product unnecessarily once assembled.
5. For the protection of your furniture, particularly items of high gloss finish, we recommend that the product is placed on a protected surface during assembly to prevent any damage.
6. During assembly please take care not to over-tighten any fittings, as this may damage the product.

Care and Maintenance of your Furniture

Please periodically check all fittings and re-tighten as necessary.

To clean your item, please use a damp cloth and wipe clean.

Never allow any kind of liquid to remain on your furniture. Absorption can cause wood to warp or finishes to de-laminate.



Please do not place hot items (e. g. hot drinks) directly on to the wood surface.

Please do not drag or pull your furniture.



WARNING! IN ORDER TO HELP PREVENT OVERTURNING THIS PRODUCT MUST BE USED WITH THE WALL ATTACHMENT DEVICE PROVIDED

Free Standing Furniture with a height over 600mm



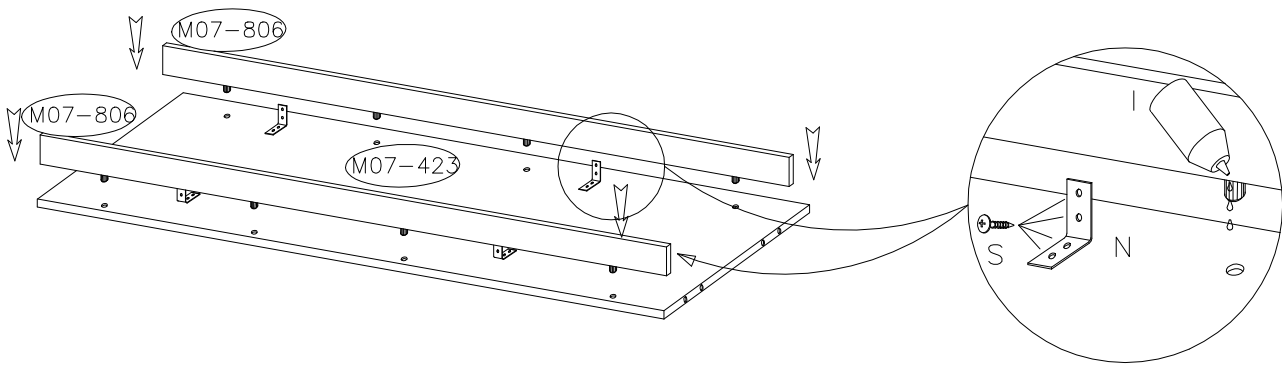
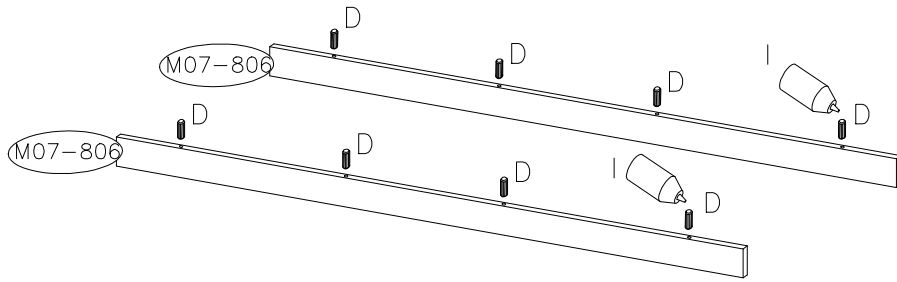

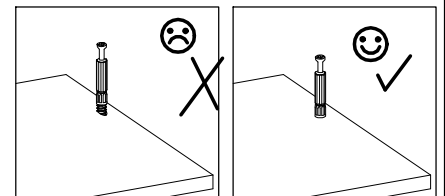
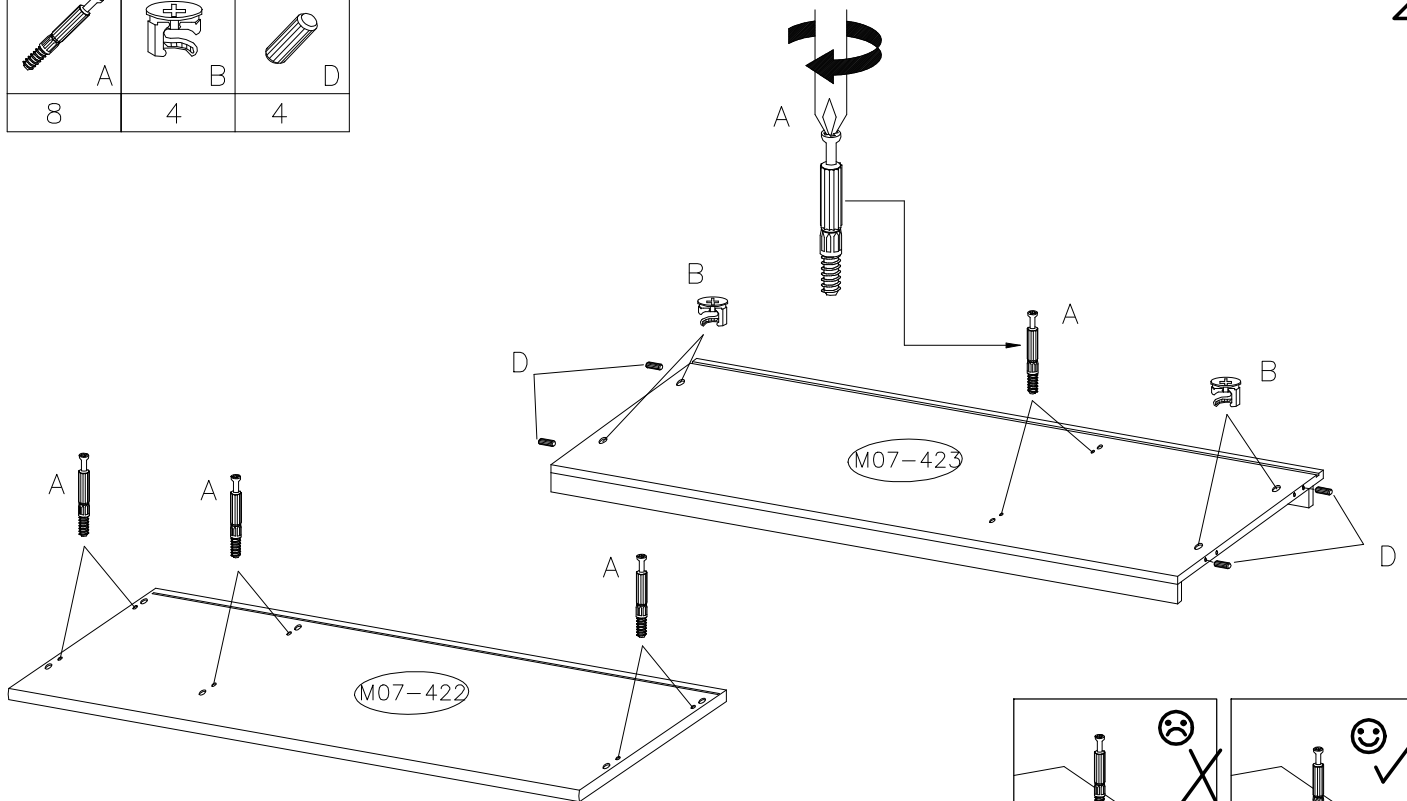

- Use the wall attachment device provided
- Never allow children to climb or hang on drawers, doors or shelves.
- Place heaviest items in the lower drawers or shelves
- Unless specifically designed to accommodate, do not set TV's or other heavy objects on top of this product.
- Never open more than one drawer at a time.

			3.5X13
D	I	N	S
8	1	4	16





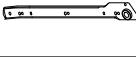

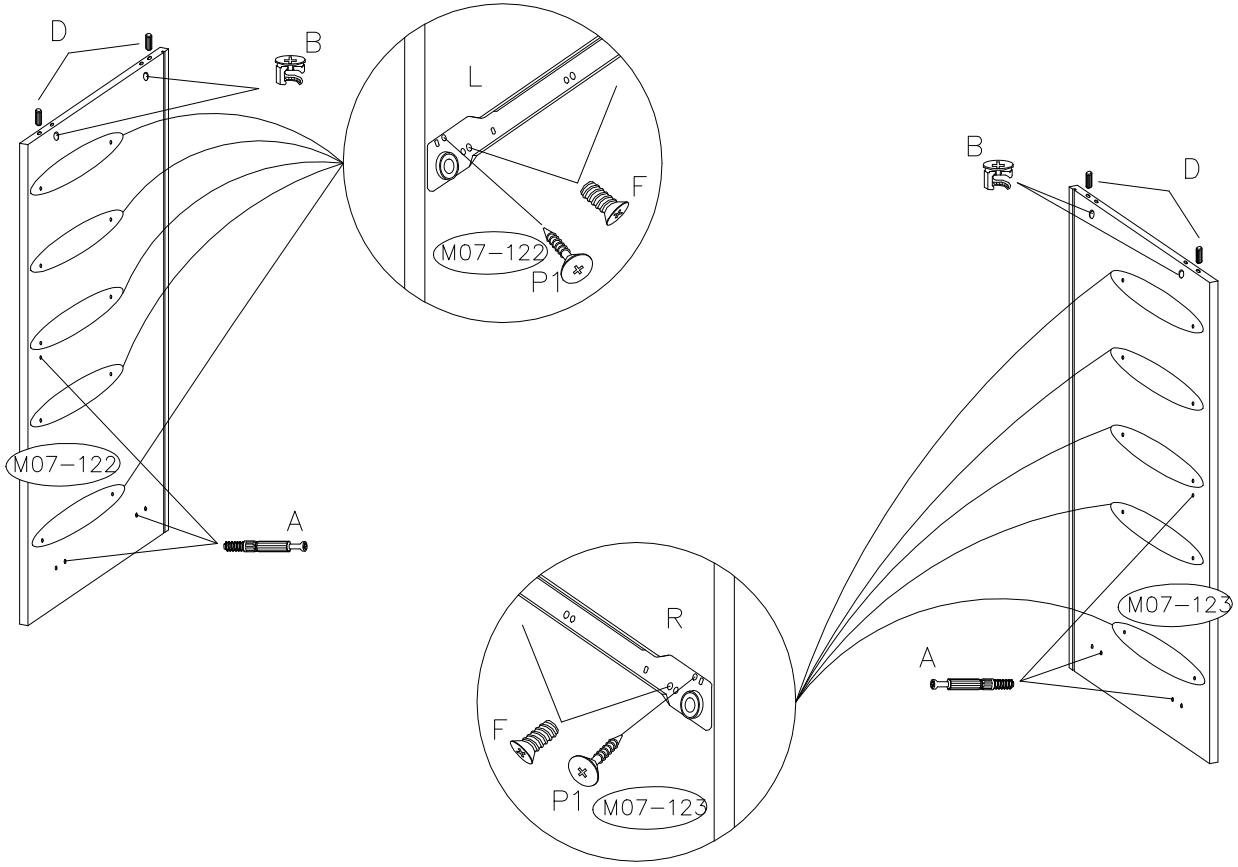

		
A	B	D
8	4	4





			6.3X13 	3.0X15 	 R  L
6	4	4	20	10	5 KPL

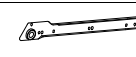

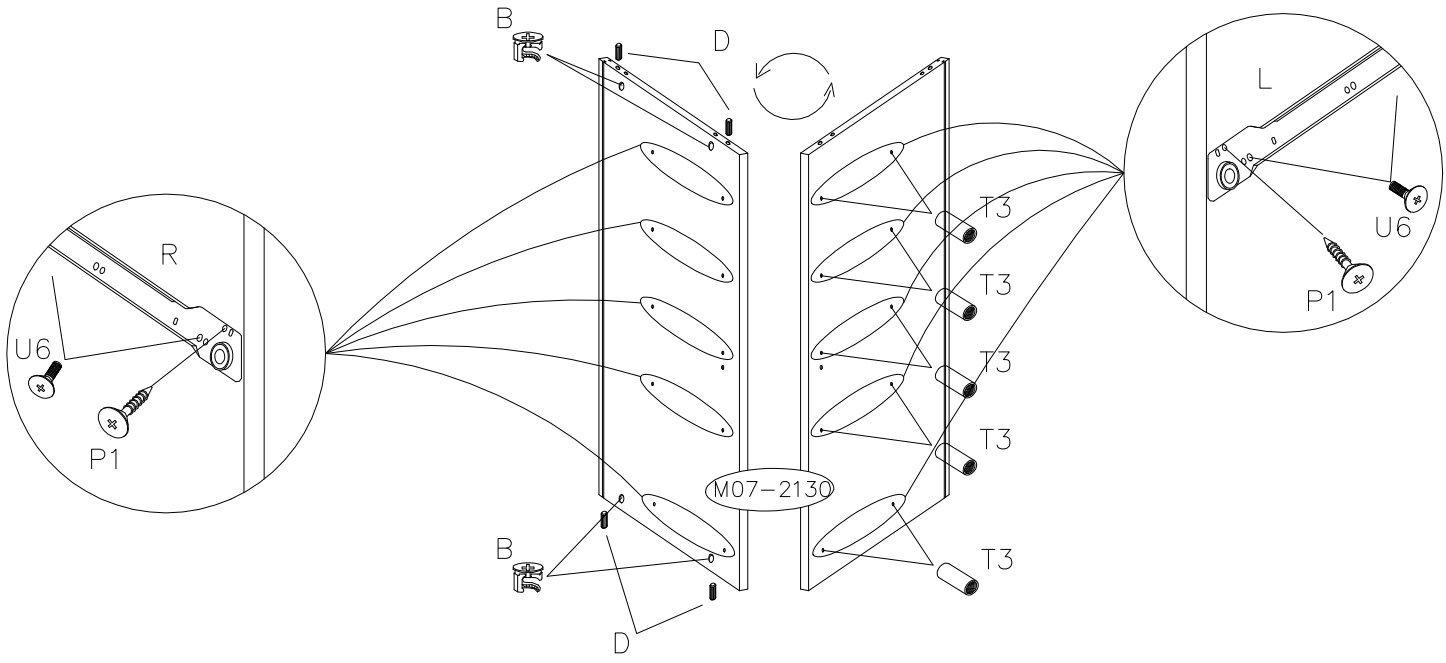
			4.0X8 	3.0X15 	 R  L
4	4	10	20	10	5 KPL

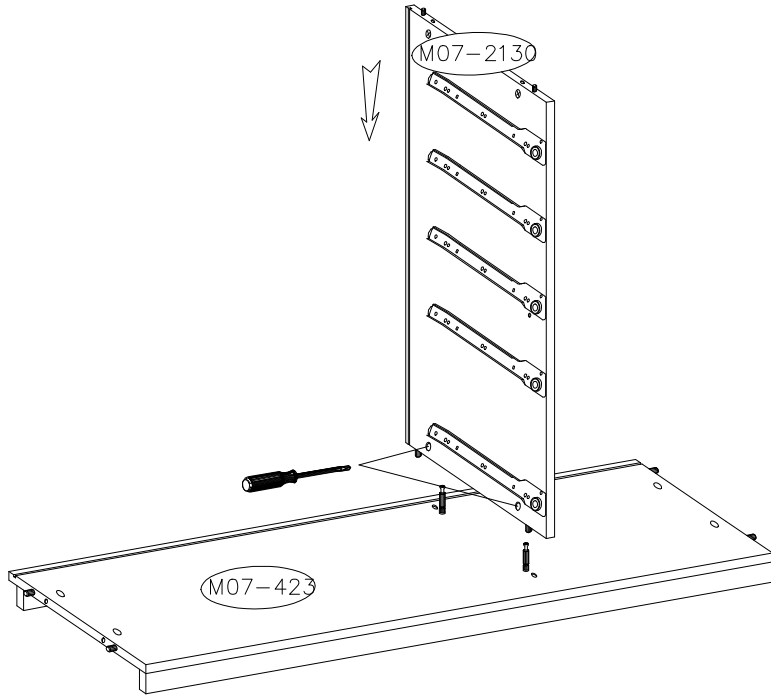





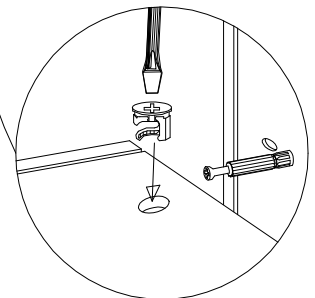
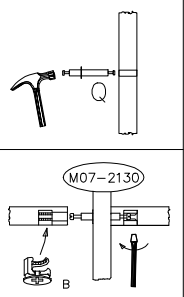
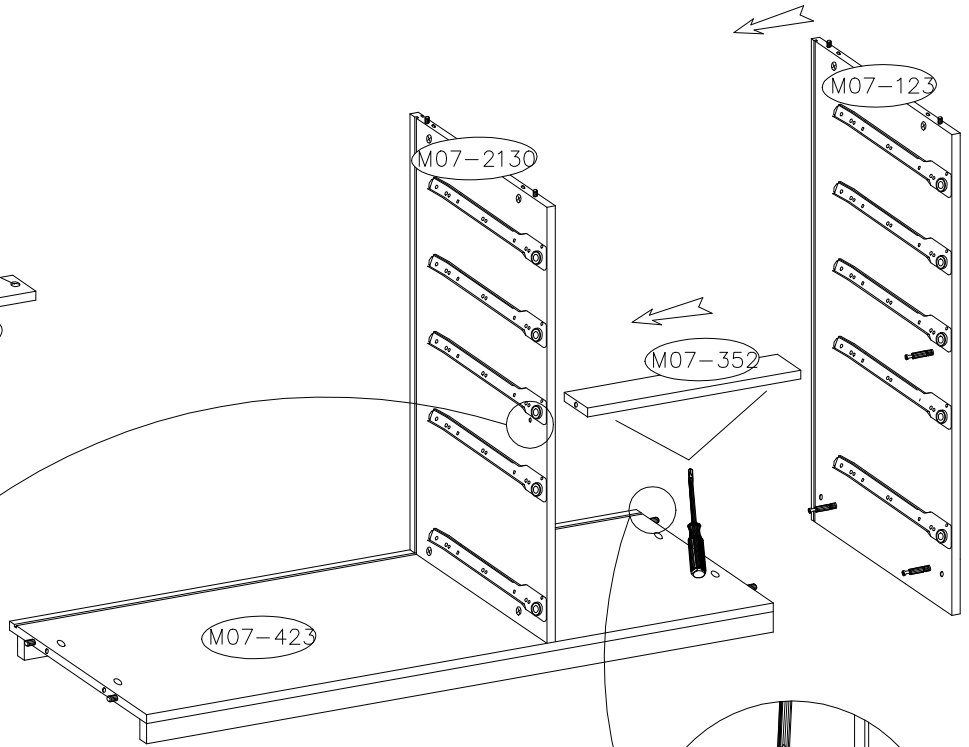
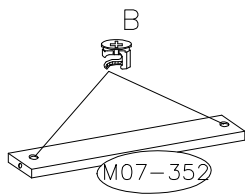

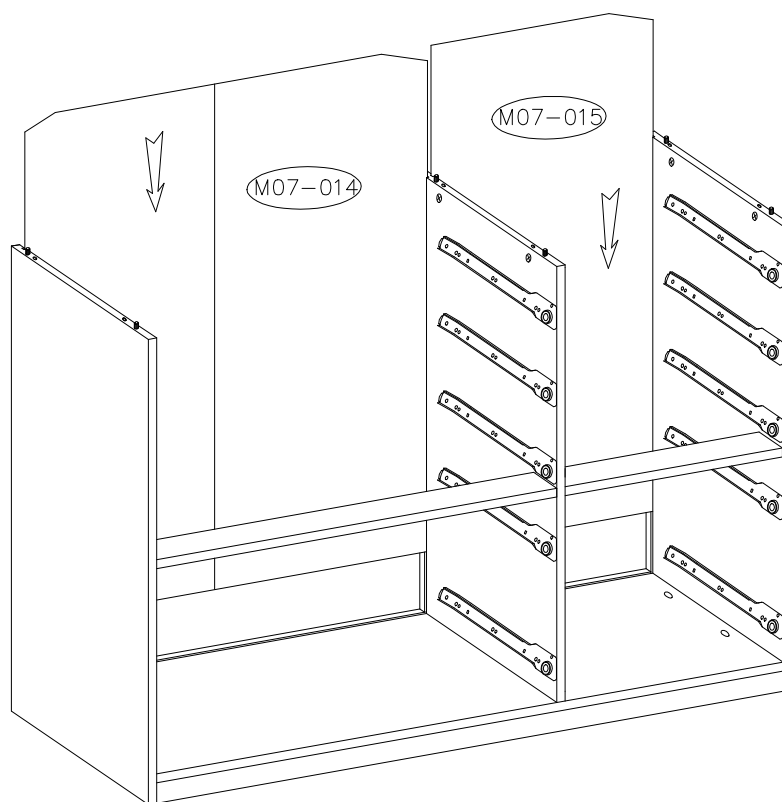
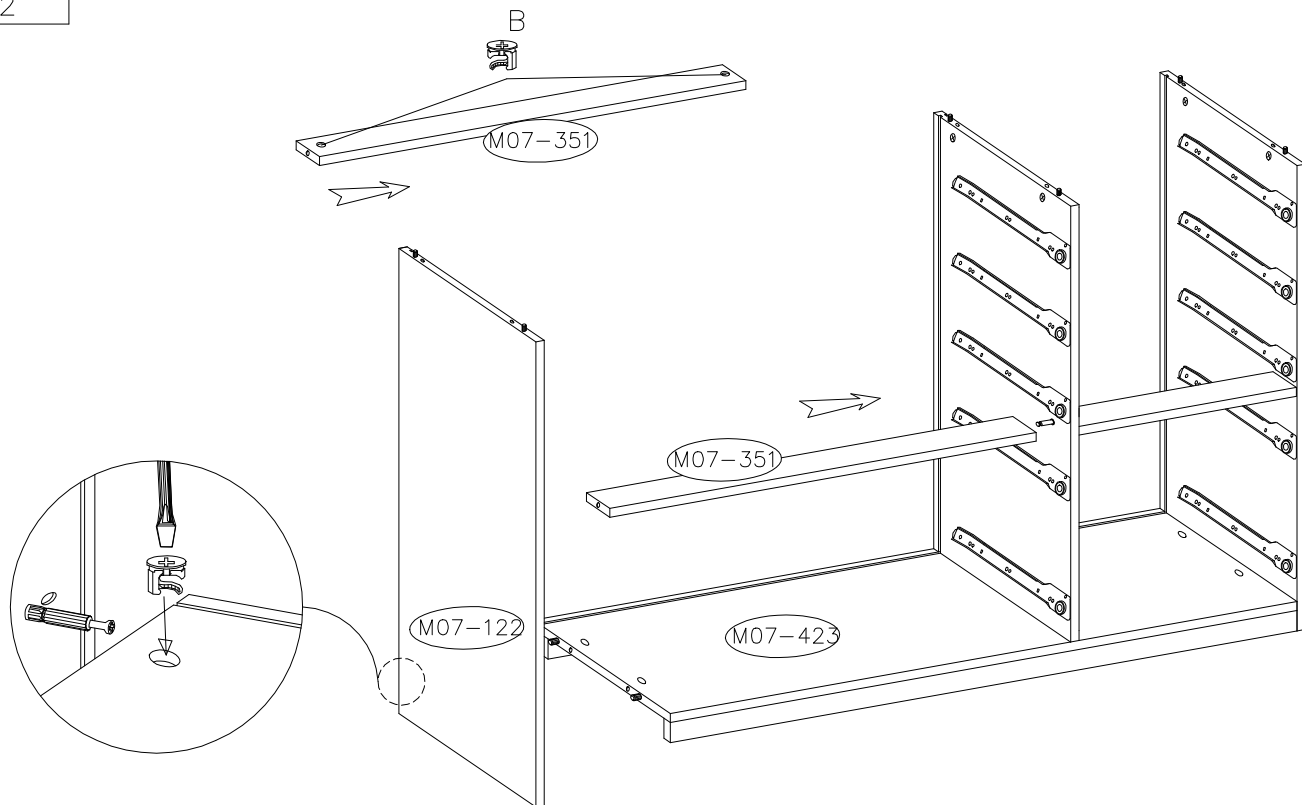
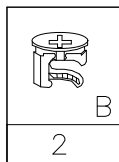

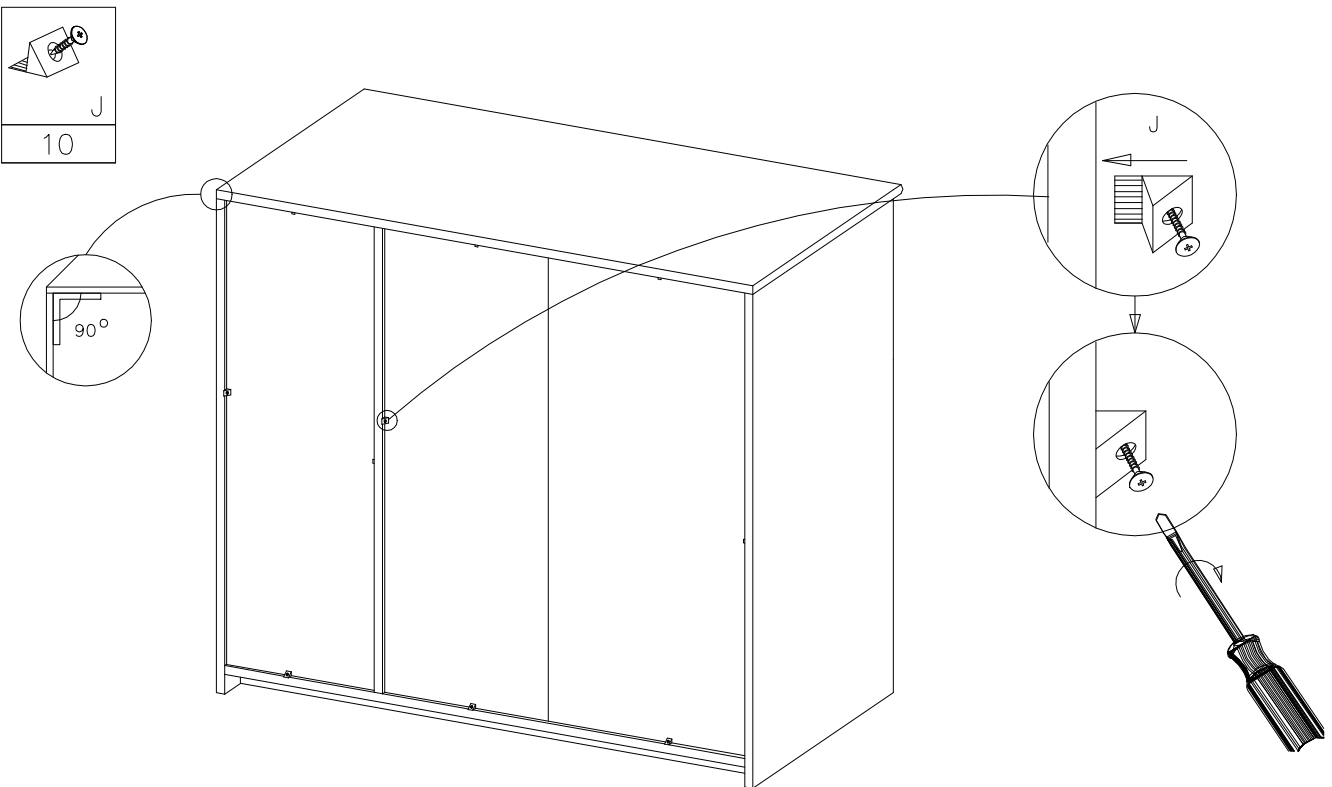
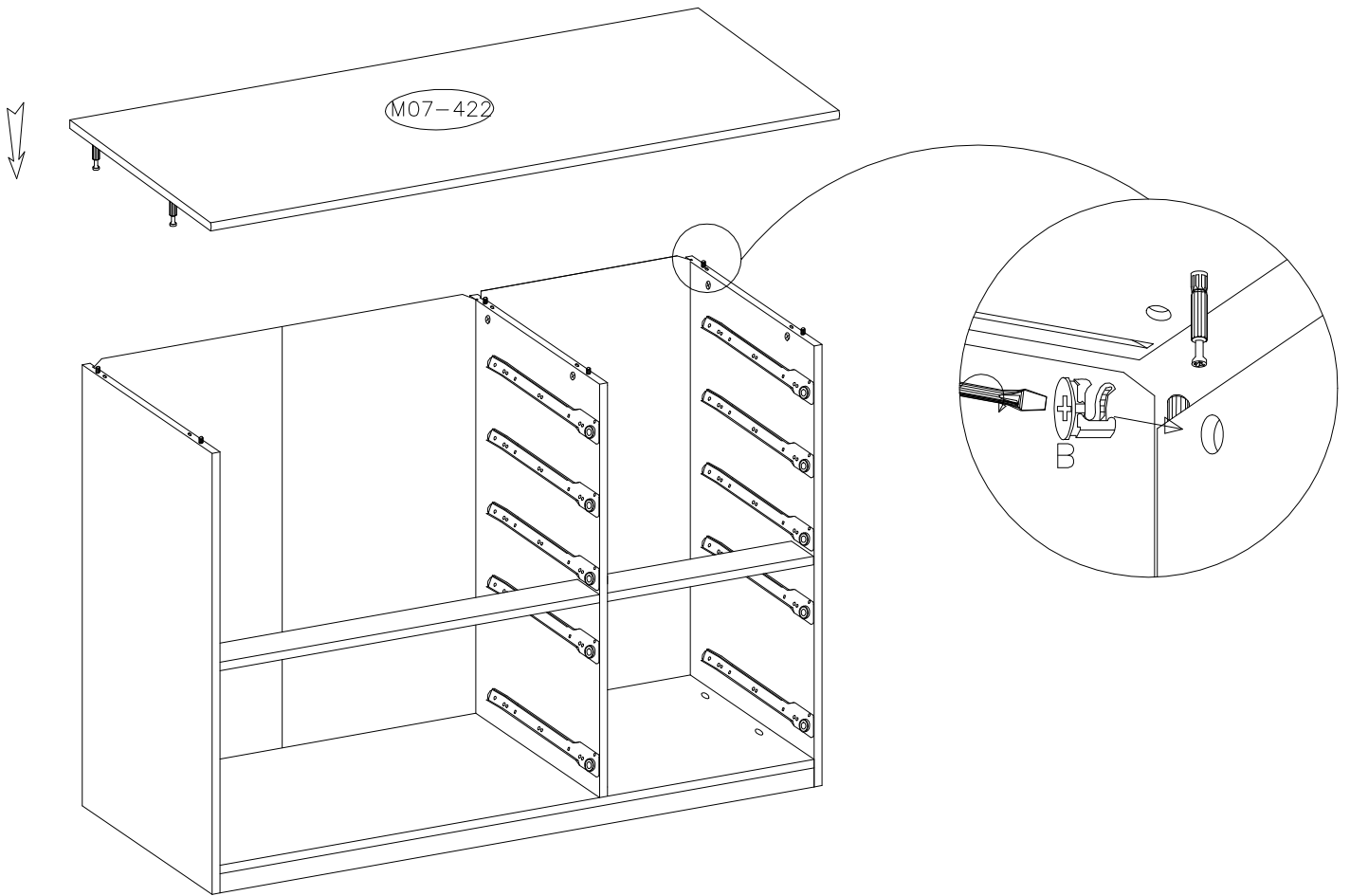



	
B	Q
2	1



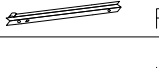





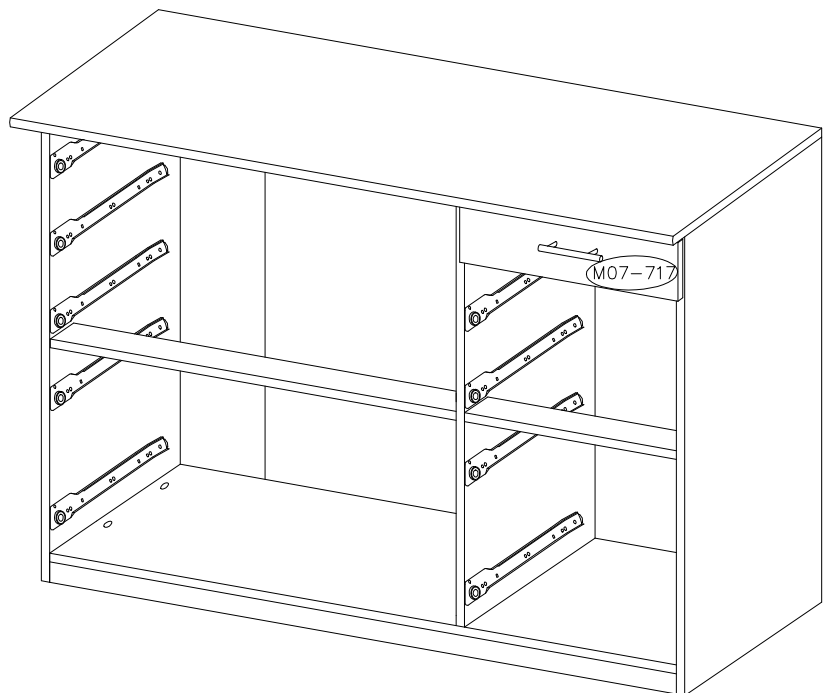
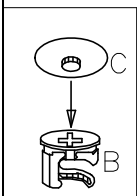
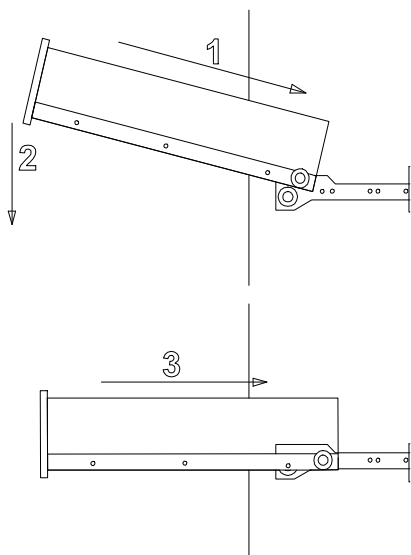
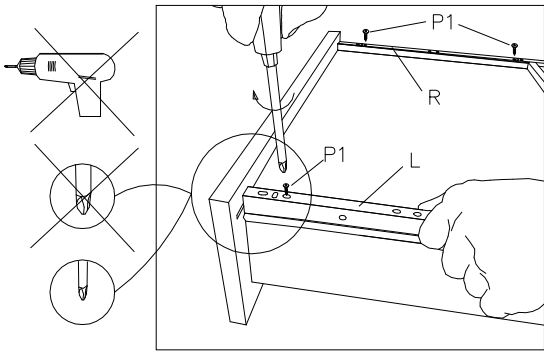
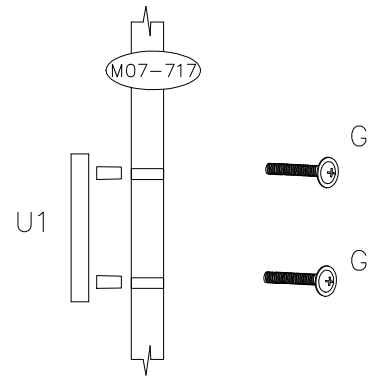
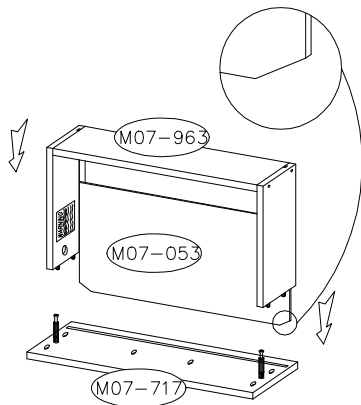
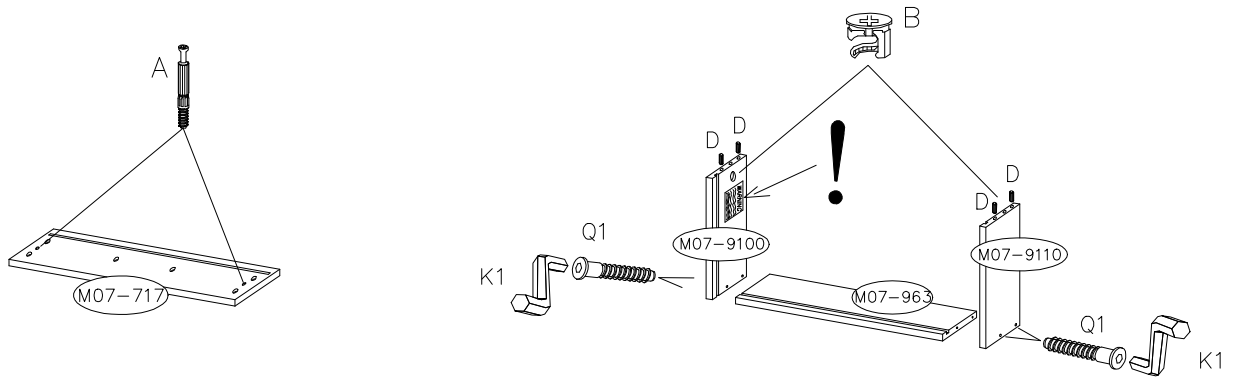

	3mm 	5.0X50 	M4.0X40 	3.0X15 					
4	1	4	2	4	1 KPL	1	2	2	2



	3mm 	5.0X50 		
36	1	40	18	18

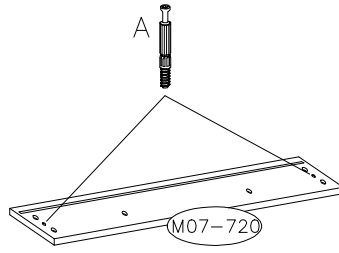
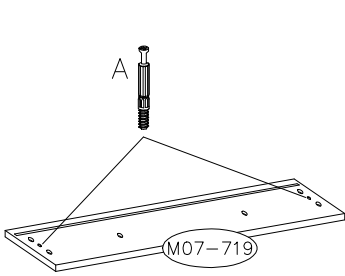
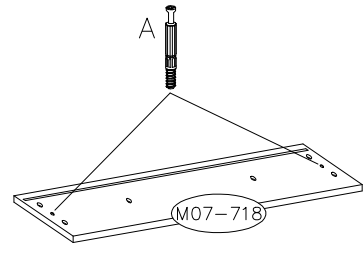
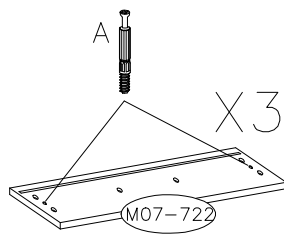
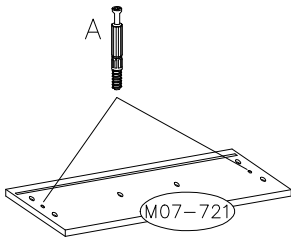



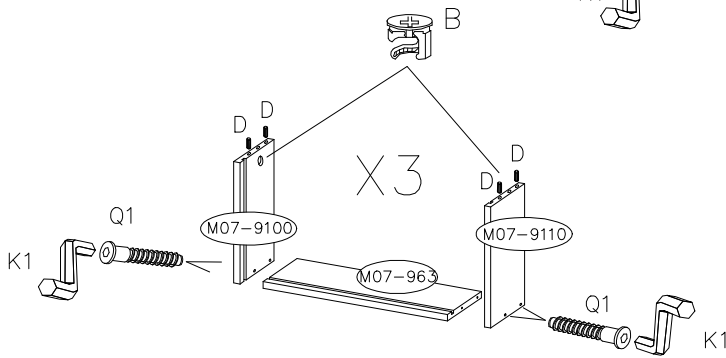
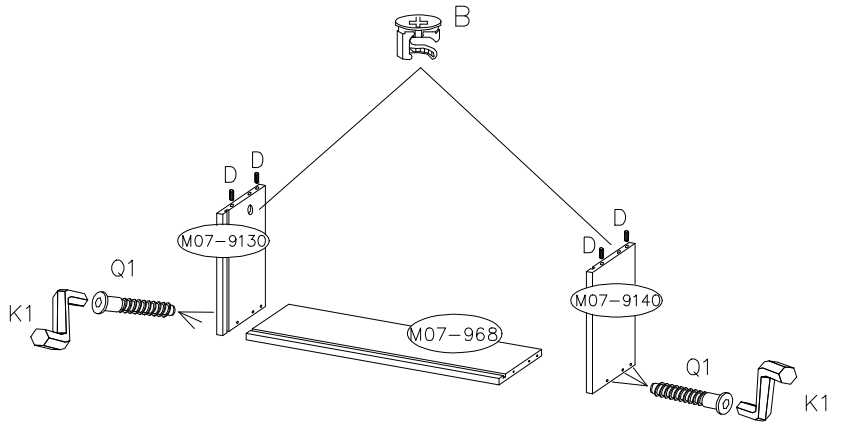

X3

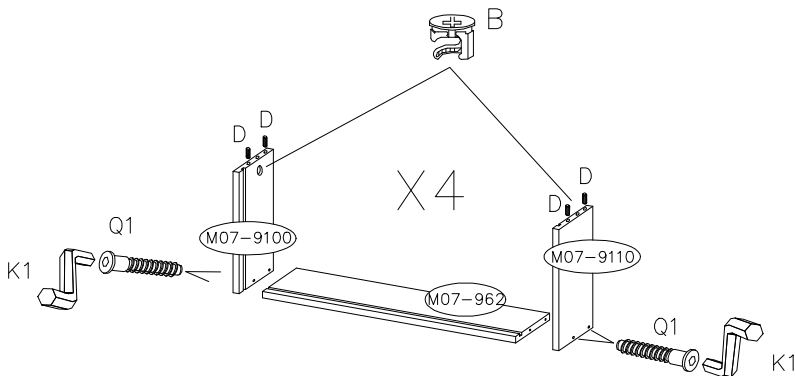
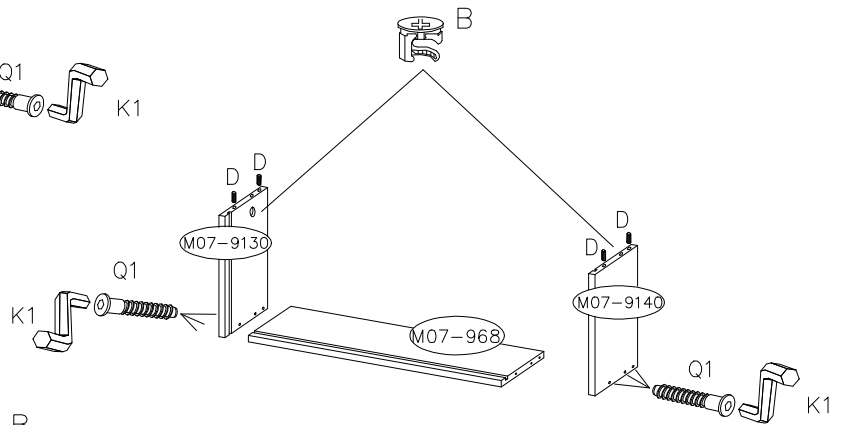

X3

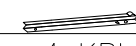

X4

M4.0X40  G	3.0X15  P1	 R  L	 U1	 C
8	16	4 KPL	4	8

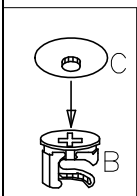
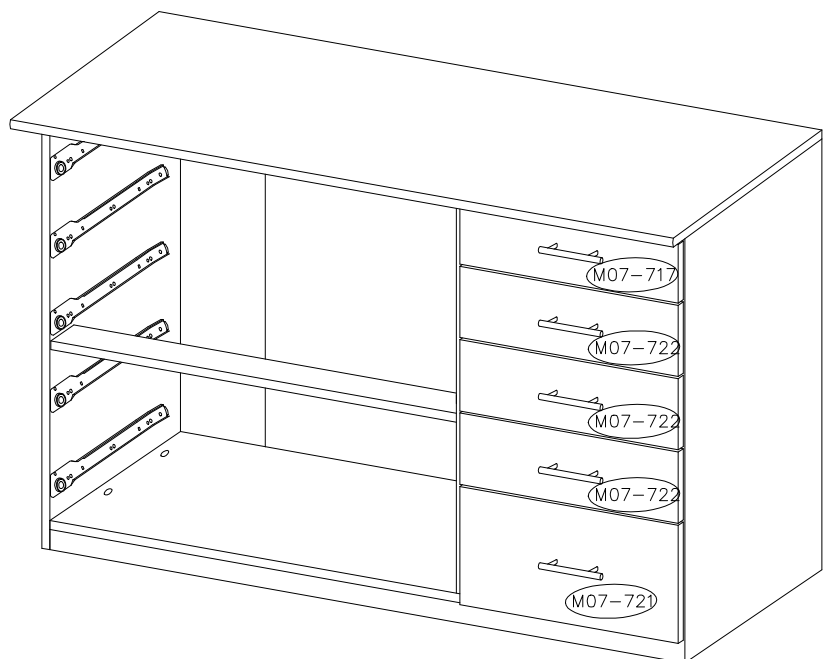
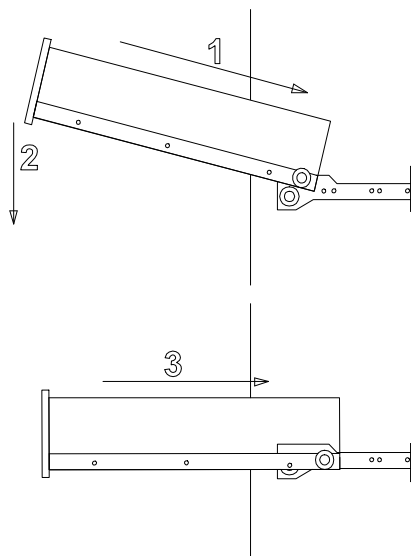
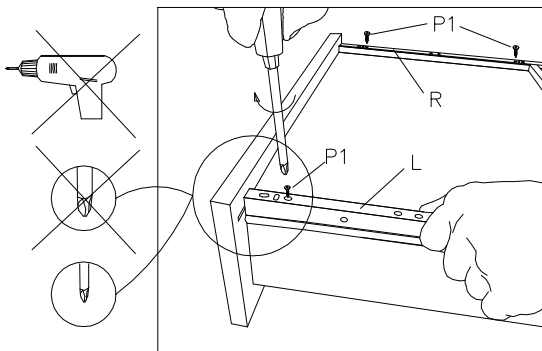
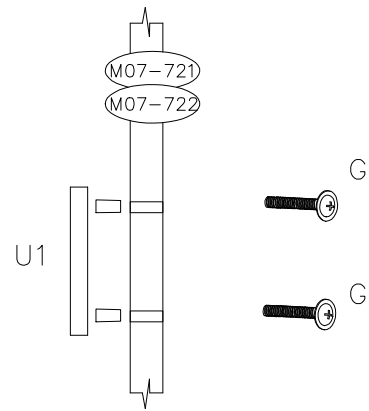
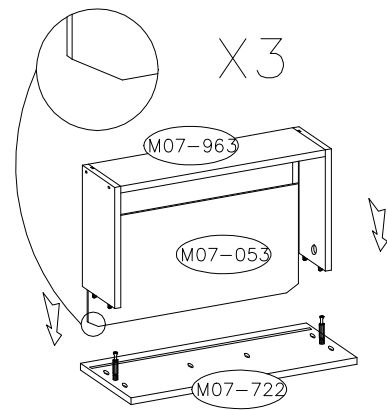
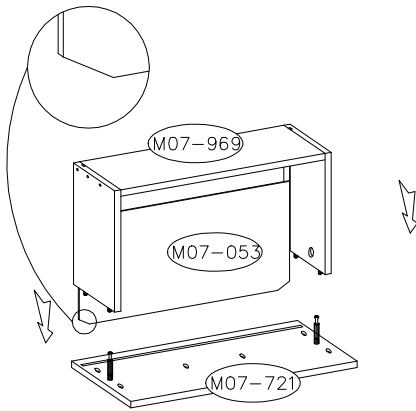

M4.0X40 G		3.0X15 P1	R L	J2	3.0X10 M1	C
10	5	20	5 KPL	5	10	10

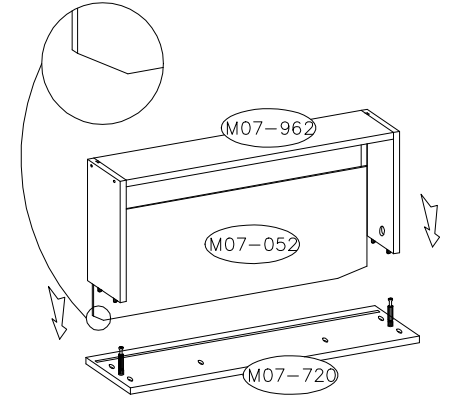
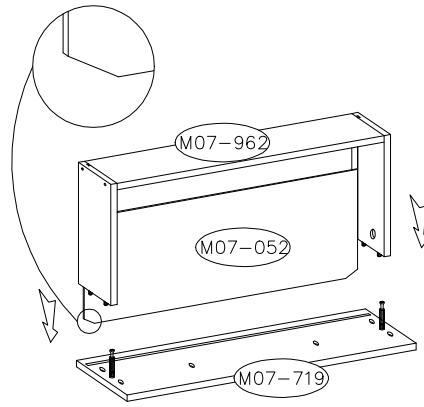
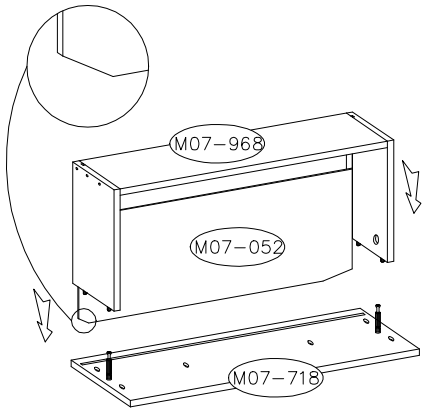

X3

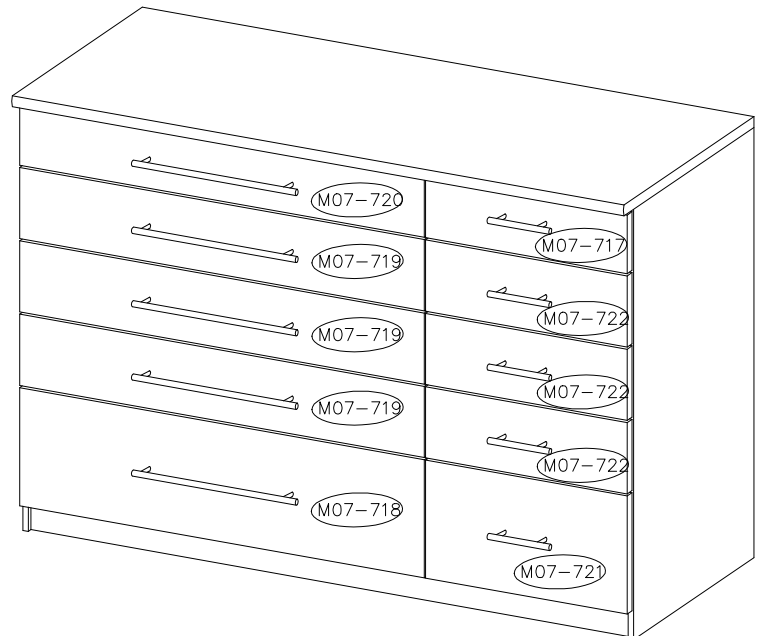
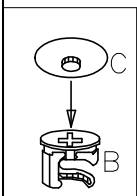
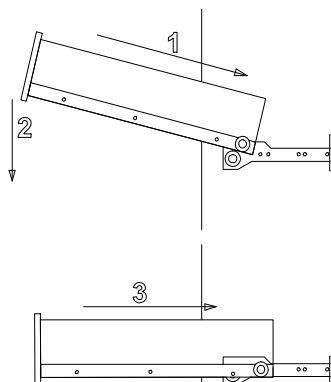
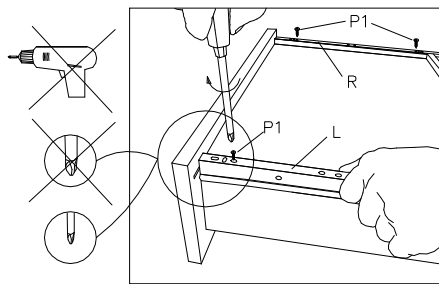
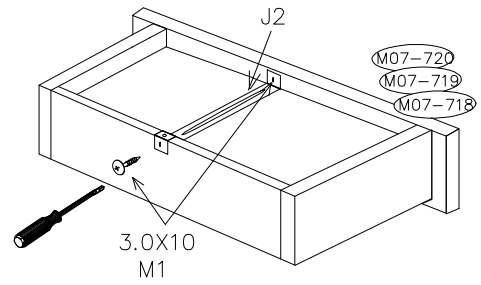
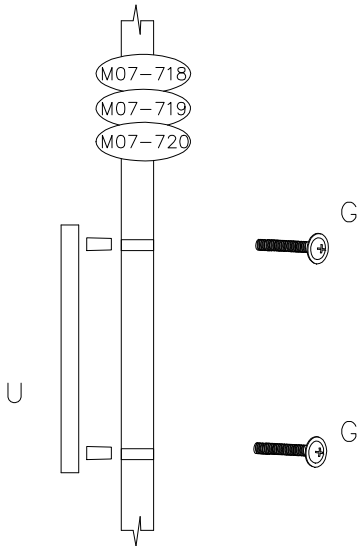

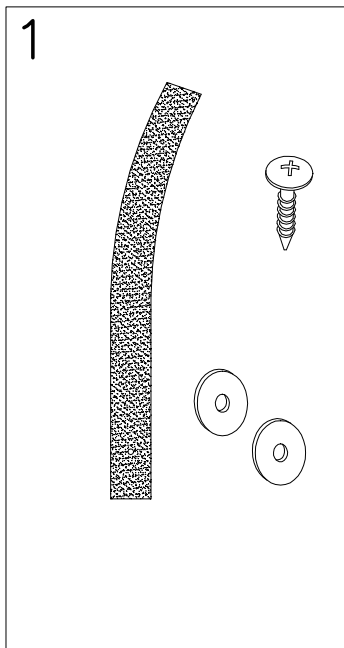

! Uwaga • Upozornini • Achtung • Attention • Caution • Figyelem ! ! Attenzione • Opgelet • Внимание • Atentie • Upozornenie • Dikkat !	
PL	Mocowanie do ściany jest jednocześnie zabezpieczeniem przed przewróceniem – koniecznie zamontować!
CZ	Do některých rodziůw ťian koniecznie zastoťowaċ ťpeciálne koĥki mocujice. Montáž na ťtĕnu ťlouží jako ochrana proti pĕvrhnutí – bezpodmiĕnĕ umĕťte! U některých typů ťtĕn může být zapoĥřebí ťpeciální hmoždinka!
D	Wandbefestigung dient als Kippschutz – unbedingt anbringen! Bei einigen Wandtypen kann ein Spezialdübel erforderlich sein!
GB	The wall fastening serves to prevent tipping – be absolutely sure to mount it! For certain wall types, a special wall plug may be necessary!
FR	La fixation murale sert de protection contre le basculement – à installer impérativement ! Pour certains types de murs il faut des chevilles spéciales !
NL	Bevestiging aan de muur dient als kantelbescherming – zeker en vast bevestigen! Bij enkele muurtypes is een speciale plug misschien vereist!
IT	Il fissaggio alla parete serve da protezione anti-ribaltamento – attaccarla assolutamente! Per alcune strutture di parete può essere necessario un tassello speciale!
HU	A termékét a falhoz kel rögzíténi, különben az felborulhat! Egyes faltípusoknál speciális tiplít kell használni!
RU	Обязательно установите крепление на стене во избежание опрокидывания! Для некоторых типов стен может потребоваться специальный дюбель!
RO	Sistemul de fixare la perete serve ca protecĥie la rĕsturnare – de montat obligatoriu!
SK	Pre niektoré druhy ťtien může být poĥrebná ťpeciálna hmoždinka!
TR	Duvardaki sabitleme, devrilmeye karĥ bir emniyet tedbiridir ve mutlaka monte edilmelidir! Bazı duvar tiplerinde bunun için özel bir dübel gerekli olabilir!

