

ASSEMBLY INSTRUCTION

MANHATTAN GB II 4 DR. ROBE WITH MIRRORS

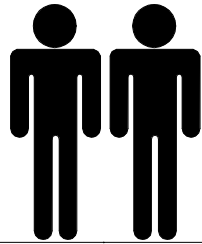

2 PERSON ASSEMBLY

FLOOR AREA
3.5M X 2.0M



CEILING HEIGHT
2.3M

(FLAT BULD)
REQUIRED ASSEMBLY SPACE

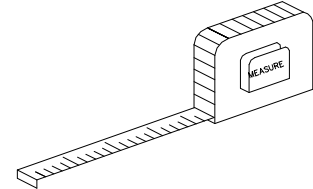
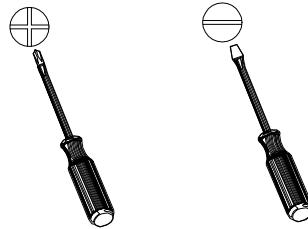

REQUIRED ASSEMBLY TOOLS

ASSEMBLED DIMENSIONS

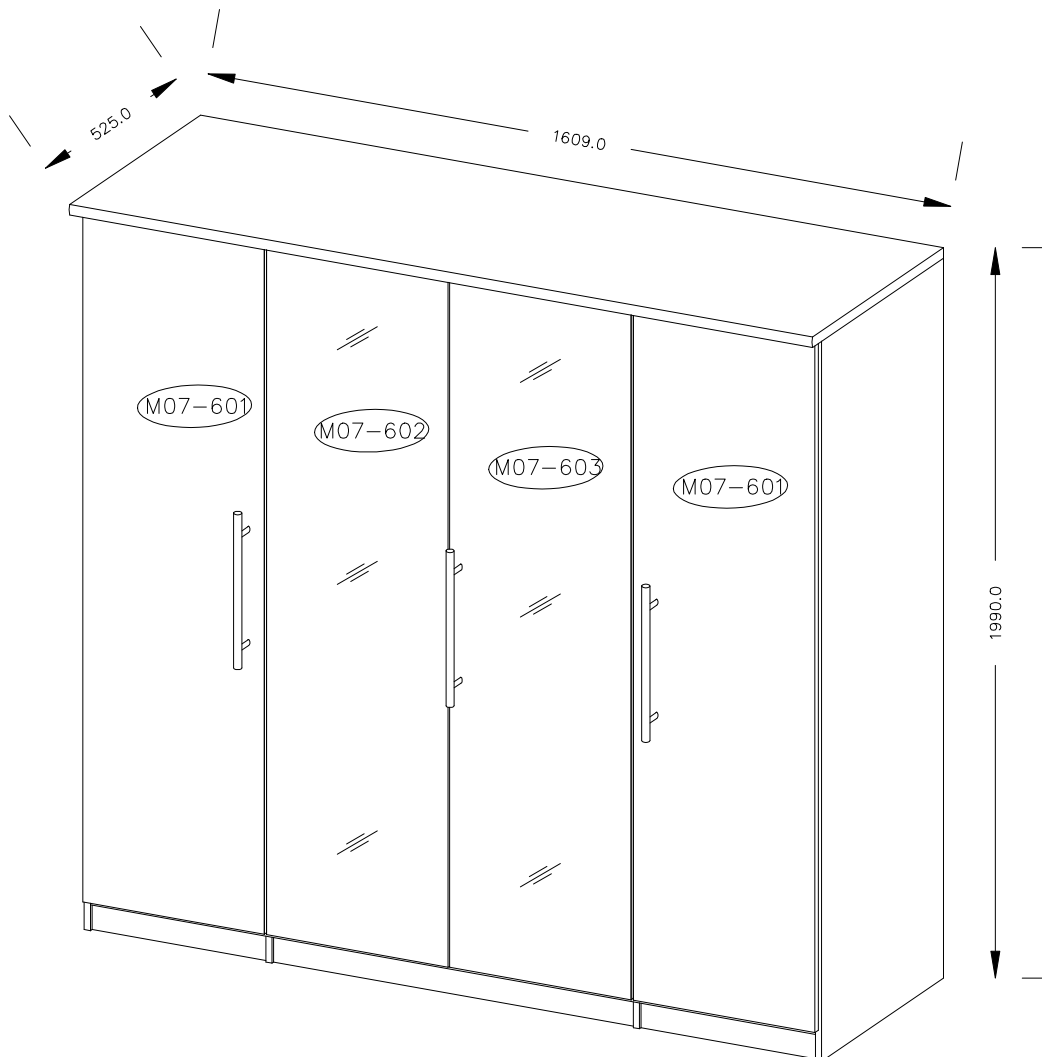

PARTS LIST

NO.	PART LIST	QTY
101	LEFT SIDE	1
102	RIGHT SIDE	1
201	DASH PANEL	2
202	SMALL LH DASH PANEL	1
203	SMALL RH DASH PANEL	1
407	UPPER PANEL	1
408	MIDDLE PANEL	1
405	NARROW MIDDLE PANEL	2
403	WIDE BOTTOM PANEL	1
406	NARROW BOTTOM PANEL	2
801	LONG PLINTH	2
802	SHORT PLINTH	4
601	DOOR LH/RH WITH HANDLE	2
602	DOOR LH/RH WITH MIRROR	1
603	DOOR WITH MIRROR AND HANDLE	1
380	BATTEN	2
701	FRONT	3
9100	LEFT SIDE OF CARCASE	3
9110	RIGHT SIDE OF CARCASE	3
960	BACK PANEL OF CARCASE	3
050	BOTTOM OF DRAWER	3
001	BACK PANEL COMBINED WITH TAPE	1
002	NARROW BACK SIDE PANEL	2

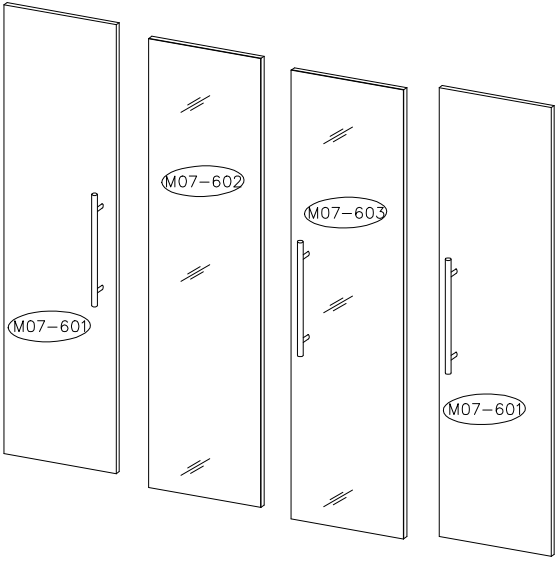
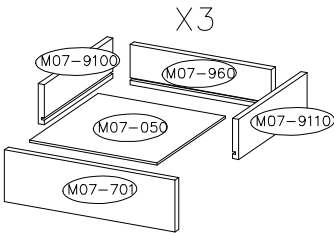
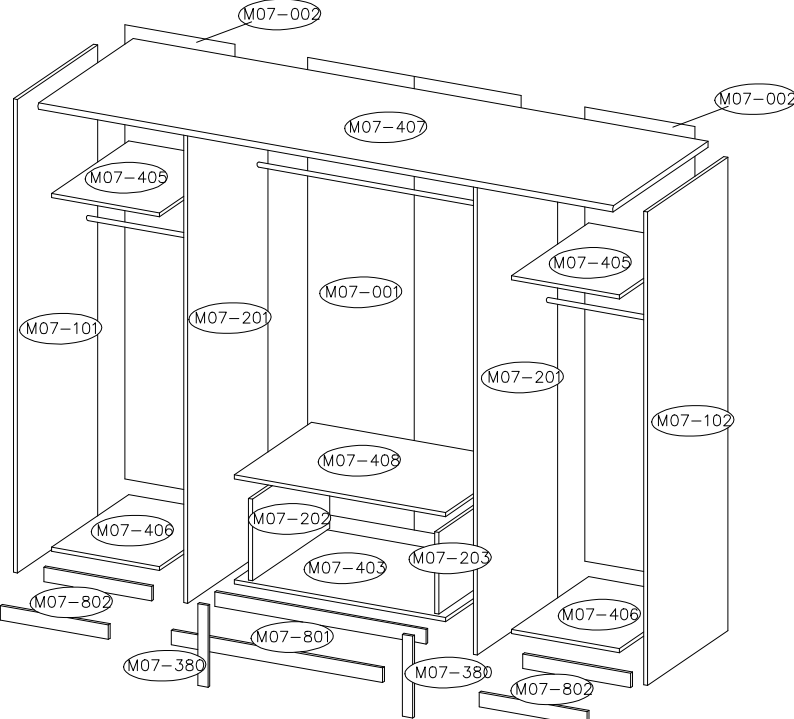







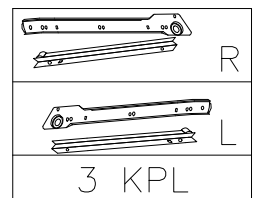
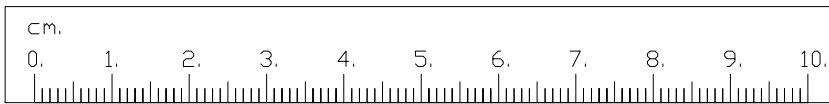
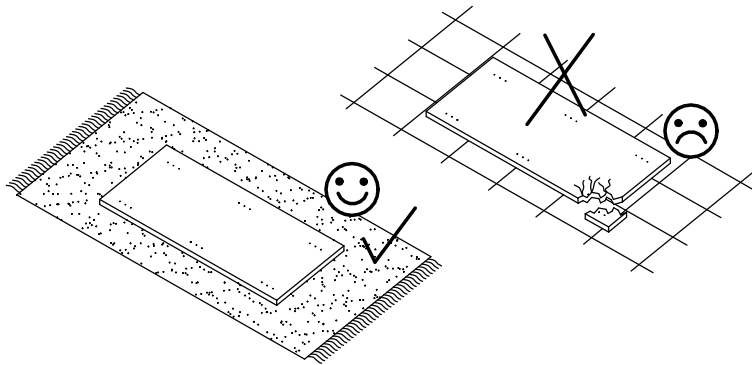
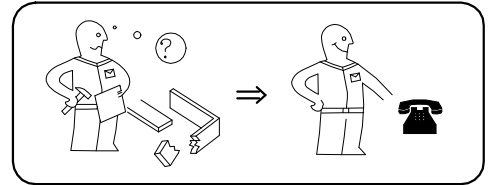
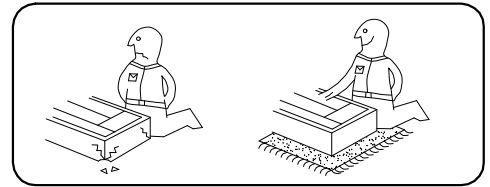
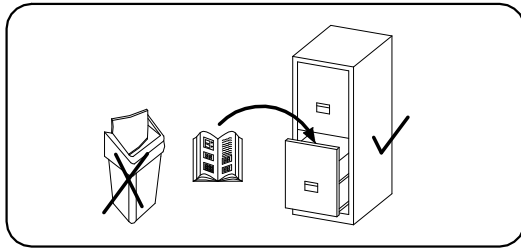









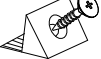

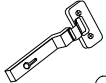



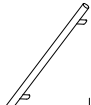





PACK 1 CONSISTS OF PARTS:
101, 102, 001, 002, 201 All

PACK 2 CONSISTS OF PARTS:
601, 602, 603

PACK 3 CONSISTS OF PARTS:
202, 203, 380, 403, 405, 406, 407, 408, 050,
9100, 9110, 960, 801, 802, Fittings



				6.3X13 	M4.0X40 				
30	38	26	48	36	4	8	1	16	6
			3.5X13 	3.0X13 		6.3X11 			
8	12	6	32	6	3	6	12	4	2
3.5X30 	M4.0X28 			3mm 	3.0X10 	3.0X15 	5.0X50 	L-773 	L-375 
4	2	2	3	1	6	18	12	1	2

Top Tips before you start!

1. Please check that all parts are present before you start the assembly of your furniture, as once assembled, the furniture is exempt from our home approval policy.
2. For ease and speed of assembly, we recommend that before you commence each step of the assembly, that you identify all the parts required for that step.
3. For larger items, please ensure that you have sufficient space and people (as indicated on page 1) to assemble your product safely.
4. We recommend that, where possible, all items are assembled near to the area in which they will be placed in use, to avoid moving the product unnecessarily once assembled.
5. For the protection of your furniture, particularly items of high gloss finish, we recommend that the product is placed on a protected surface during assembly to prevent any damage.
6. During assembly please take care not to over-tighten any fittings, as this may damage the product.

Care and Maintenance of your Furniture

Please periodically check all fittings and re-tighten as necessary.

To clean your item, please use a damp cloth and wipe clean.

Never allow any kind of liquid to remain on your furniture. Absorption can cause wood to warp or finishes to de-laminate.



Please do not place hot items (e. g. hot drinks) directly on to the wood surface.

Please do not drag or pull your furniture.



WARNING! IN ORDER TO HELP PREVENT OVERTURNING THIS PRODUCT MUST BE USED WITH THE WALL ATTACHMENT DEVICE PROVIDED

Free Standing Furniture with a height over 600mm

- Use the wall attachment device provided
- Never allow children to climb or hang on drawers, doors or shelves.
- Place heaviest items in the lower drawers or shelves
- Unless specifically designed to accommodate, do not set TV's or other heavy objects on top of this product.
- Never open more than one drawer at a time.

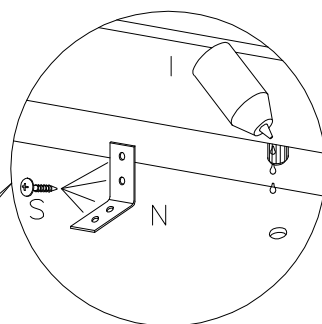
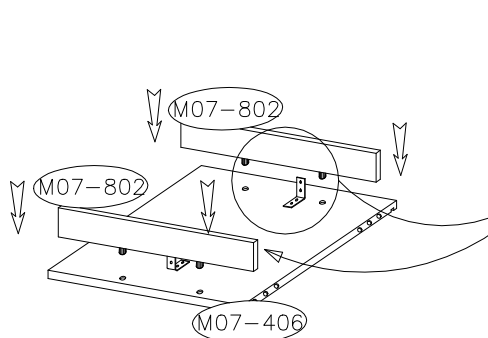
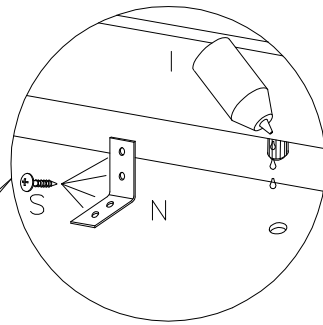
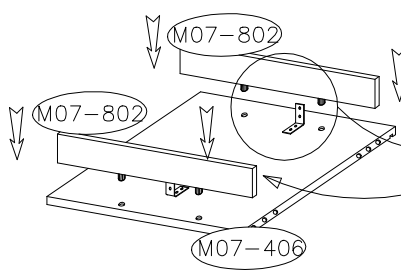
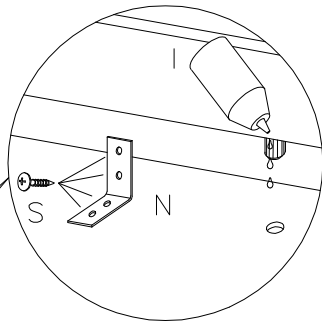
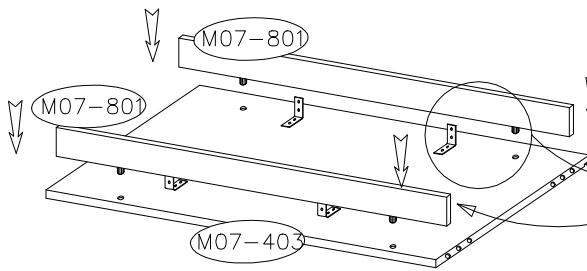
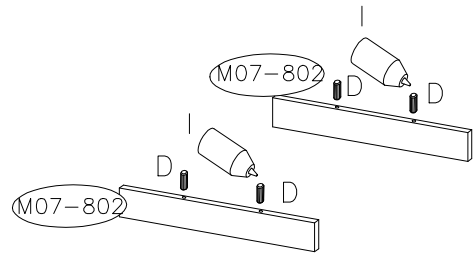
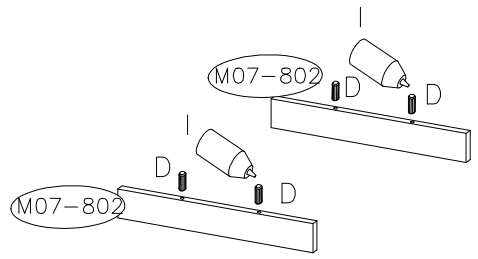
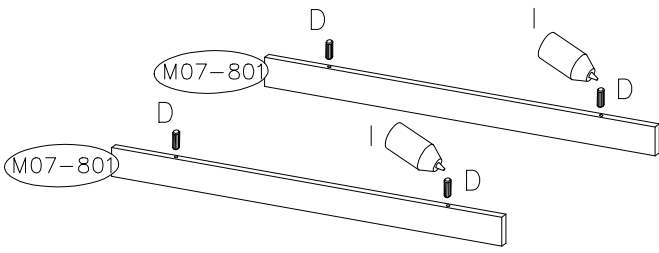
			3.5X13
D	I	N	S
12	1	8	32



		
A	B	D
4	12	12

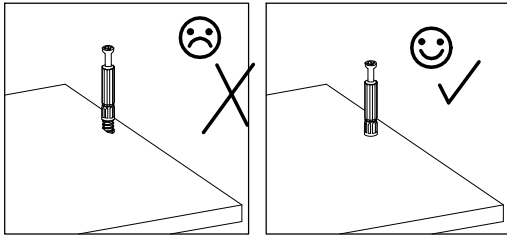
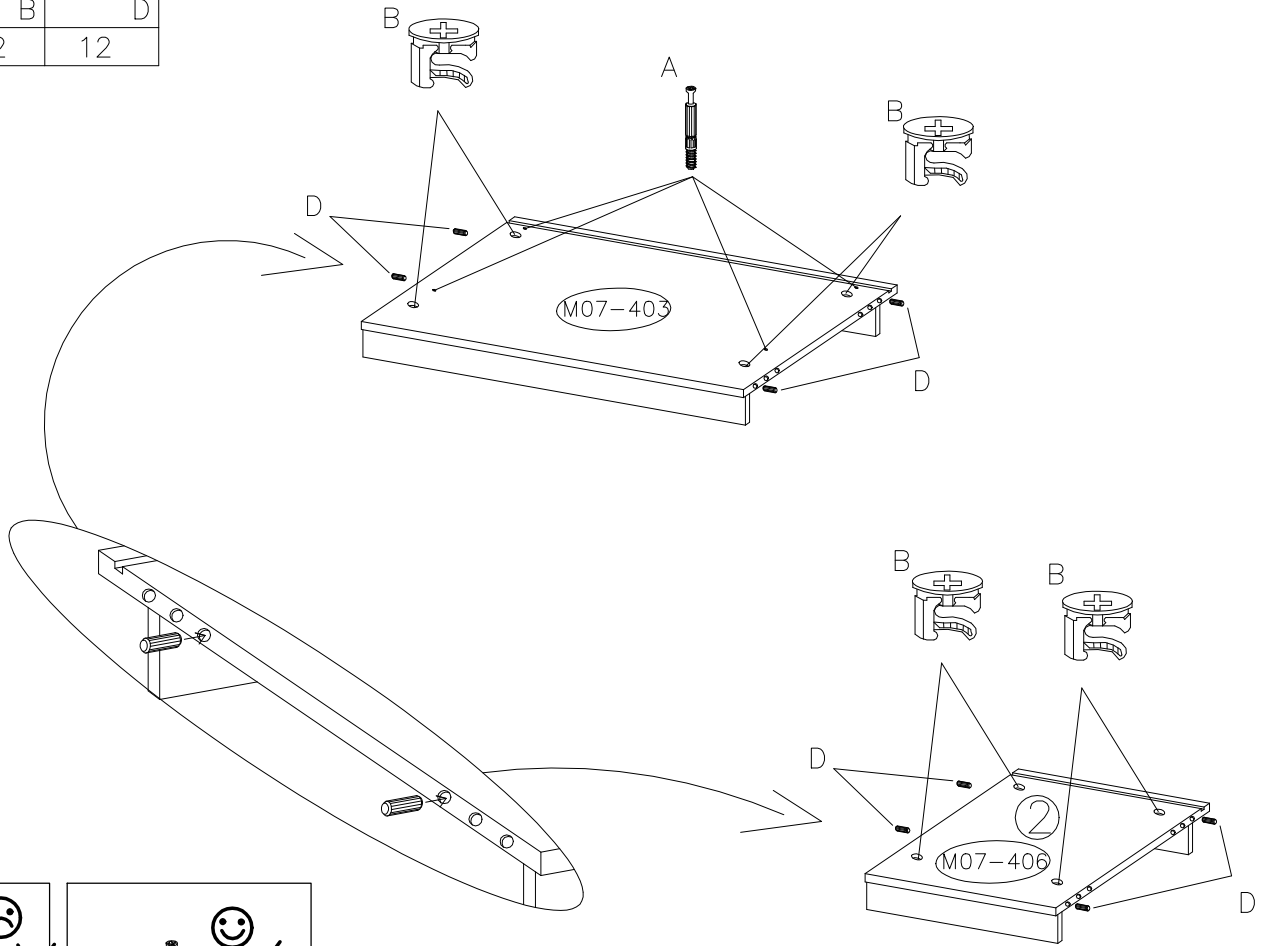

For the other Part P24-406 fix the dowels near to the front and back outside edges as shown

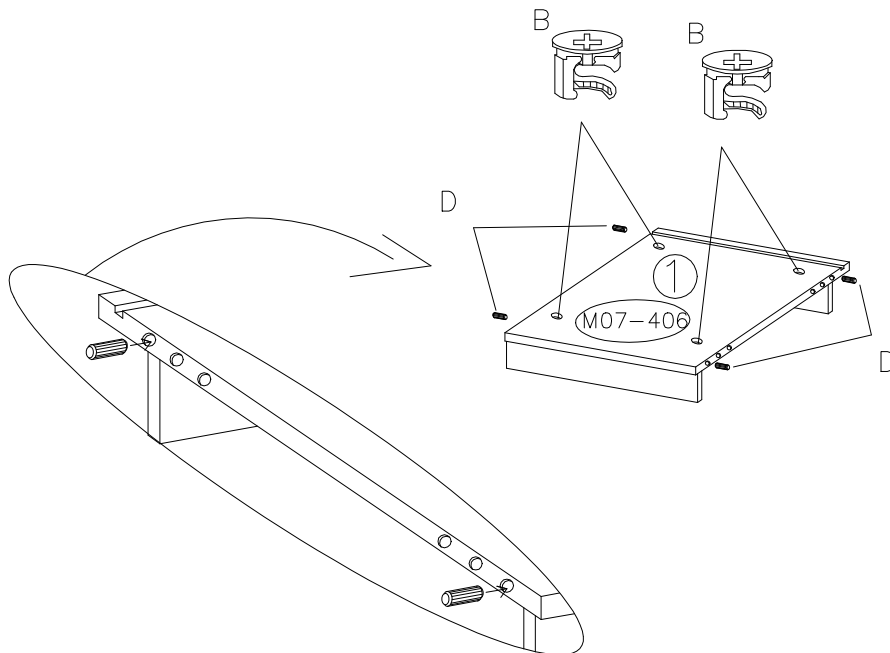

3

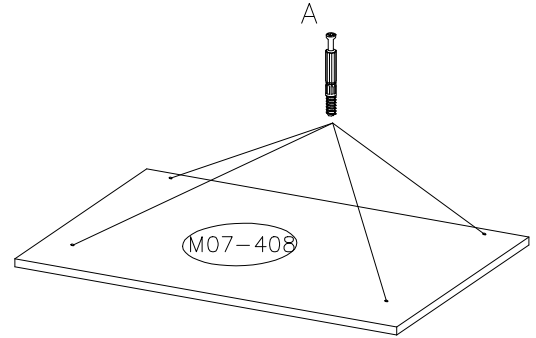
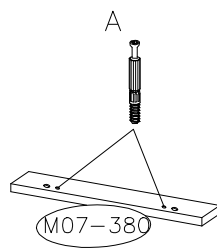
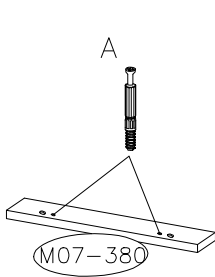
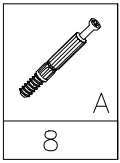



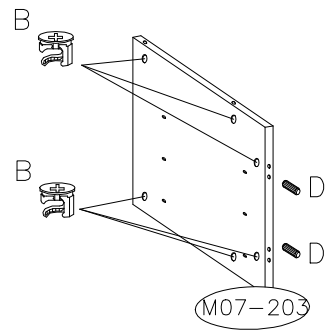
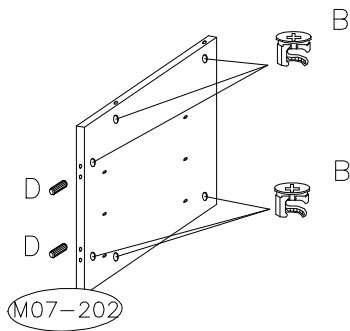
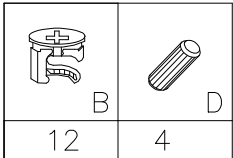

4

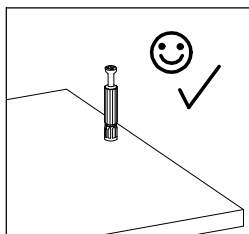
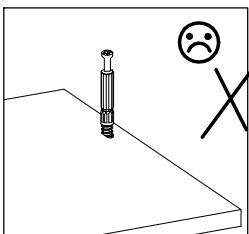
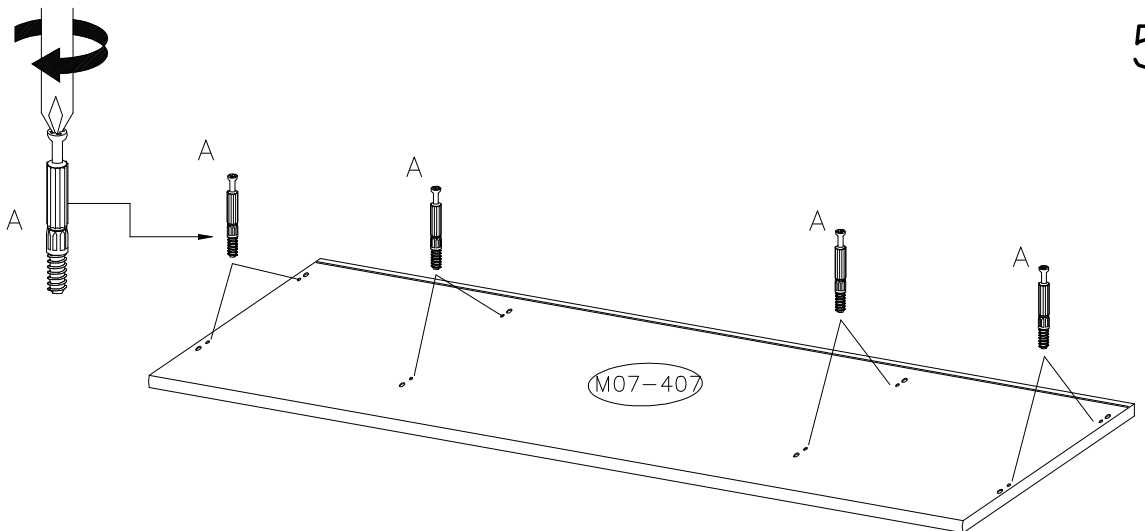
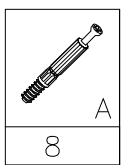



5



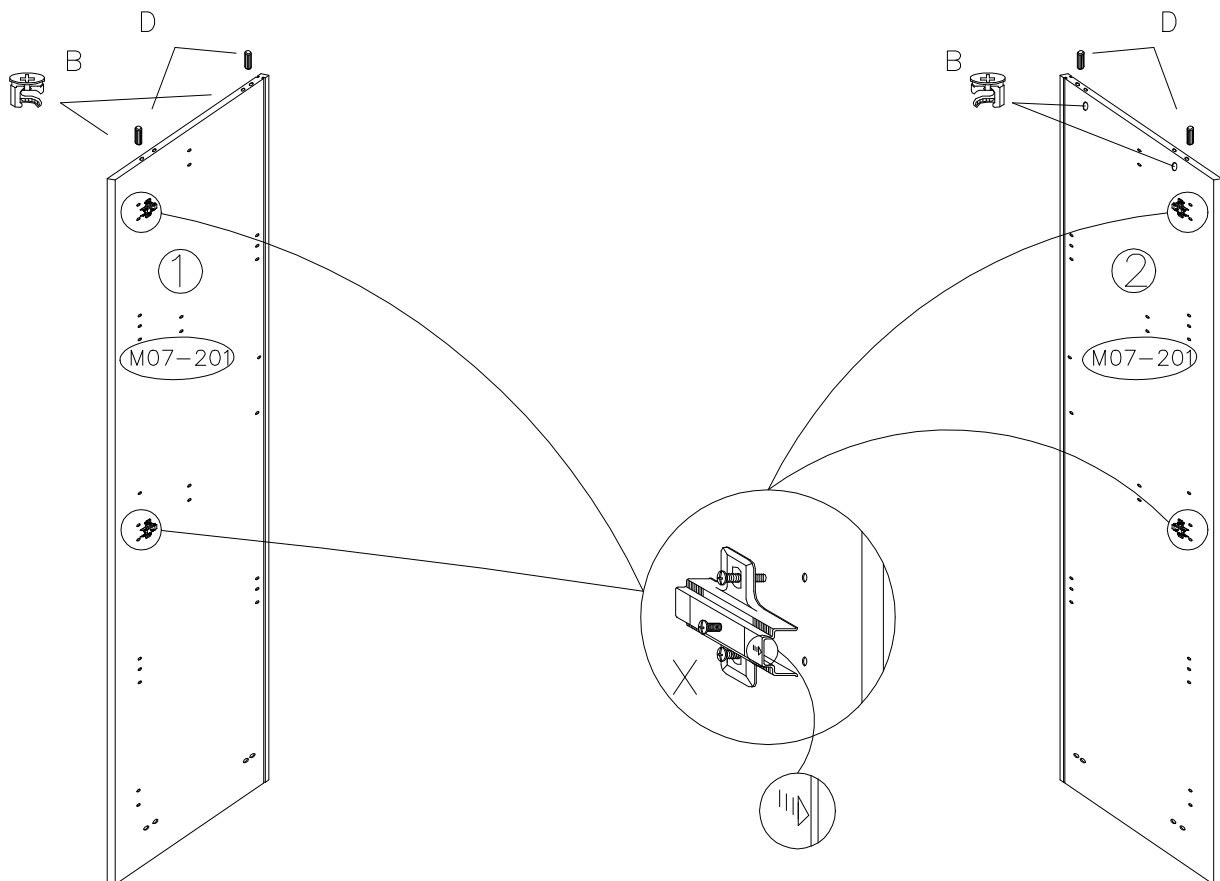
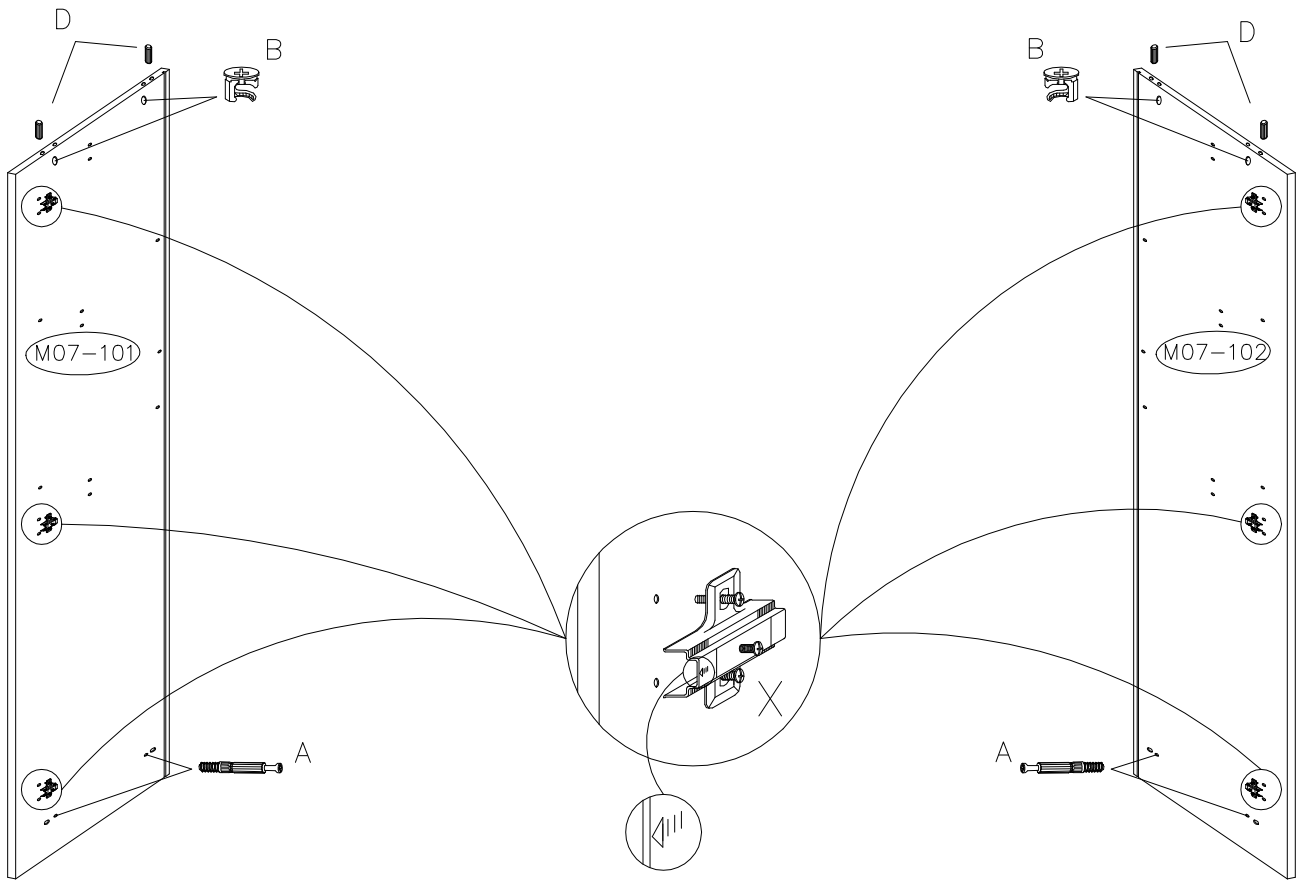

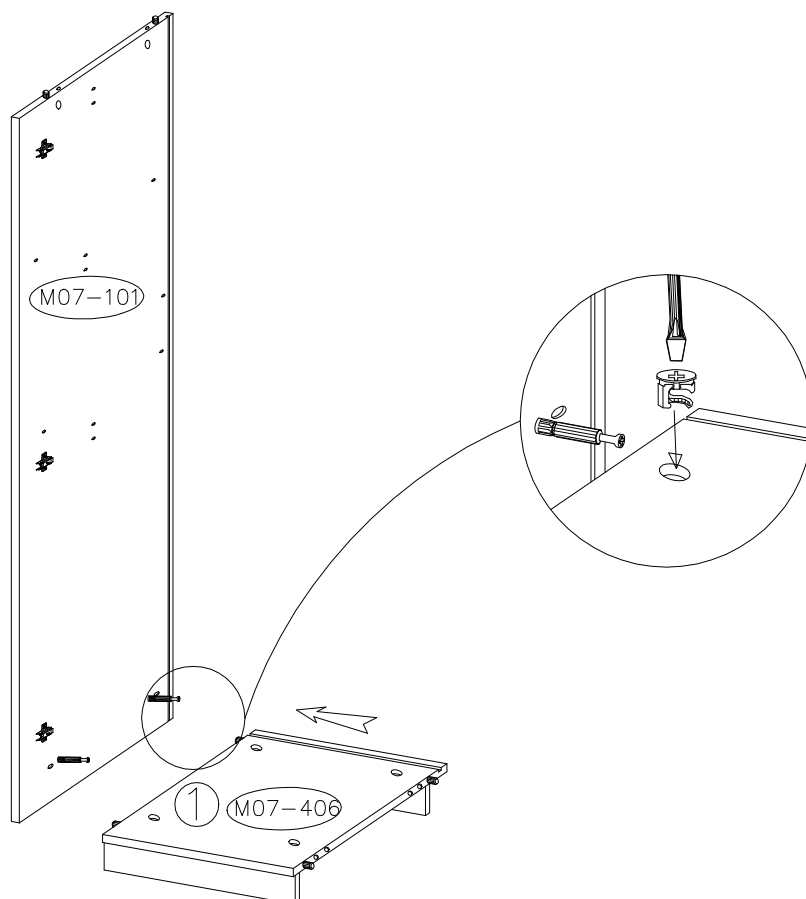
			
A	B	D	X
4	8	8	10





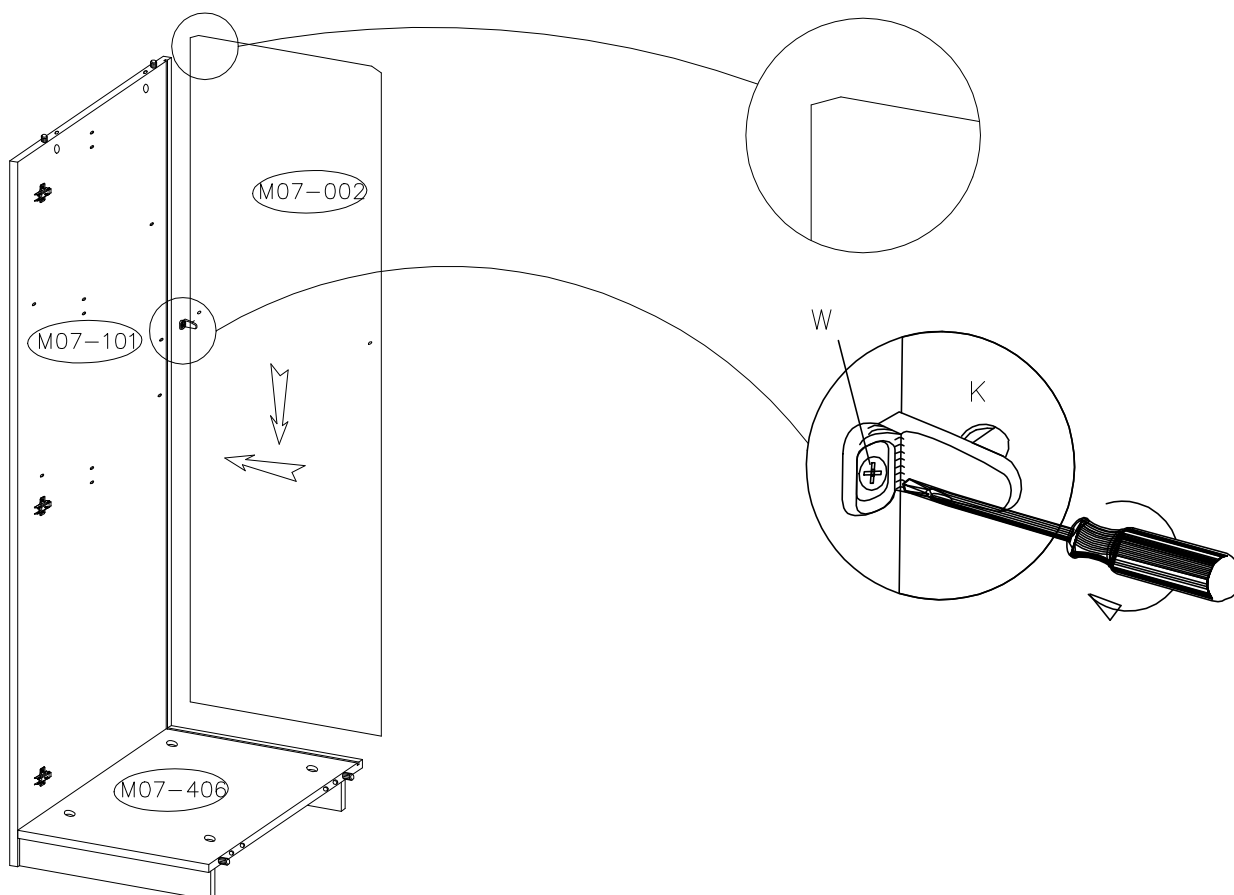



	6.3X11
K	W
1	1

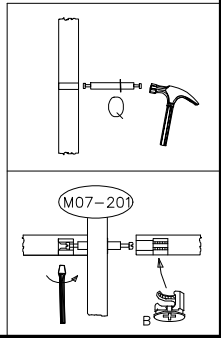
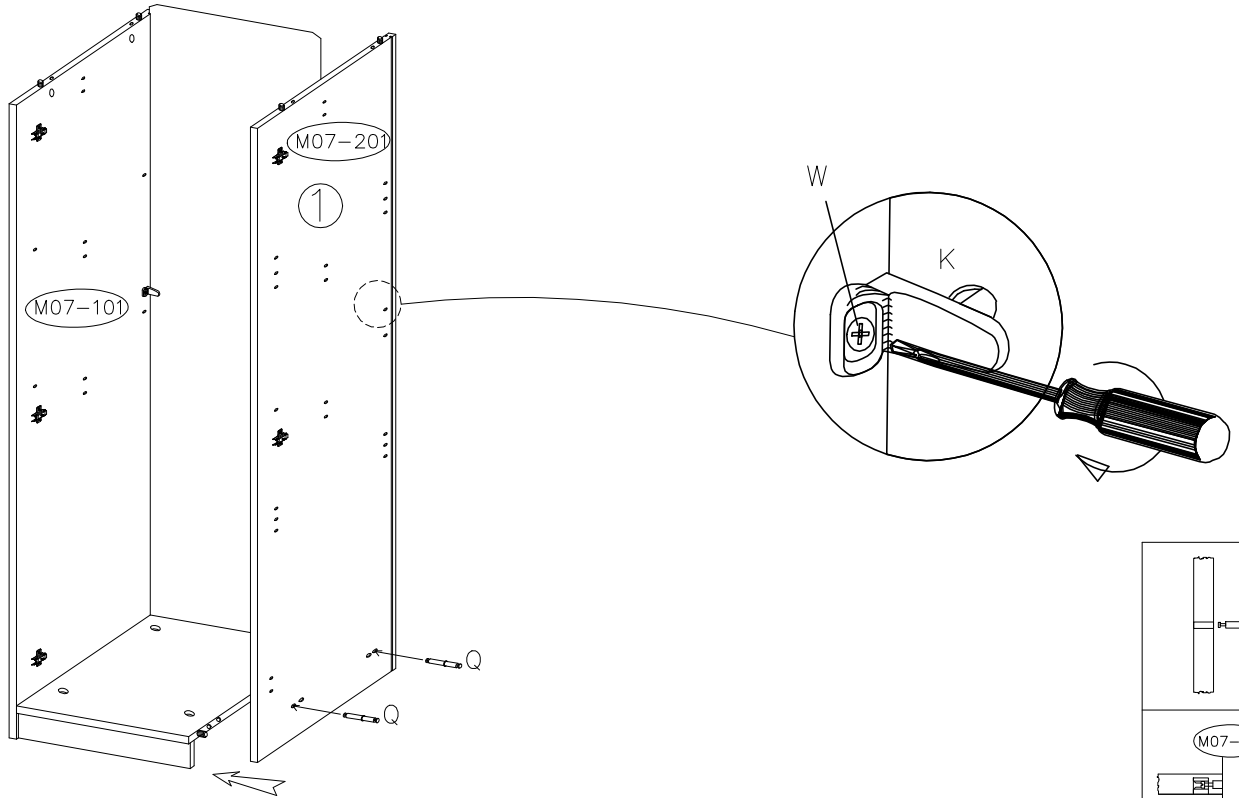

	6.3X11	
K		W
1	1	2





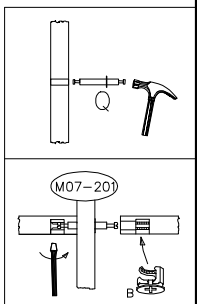
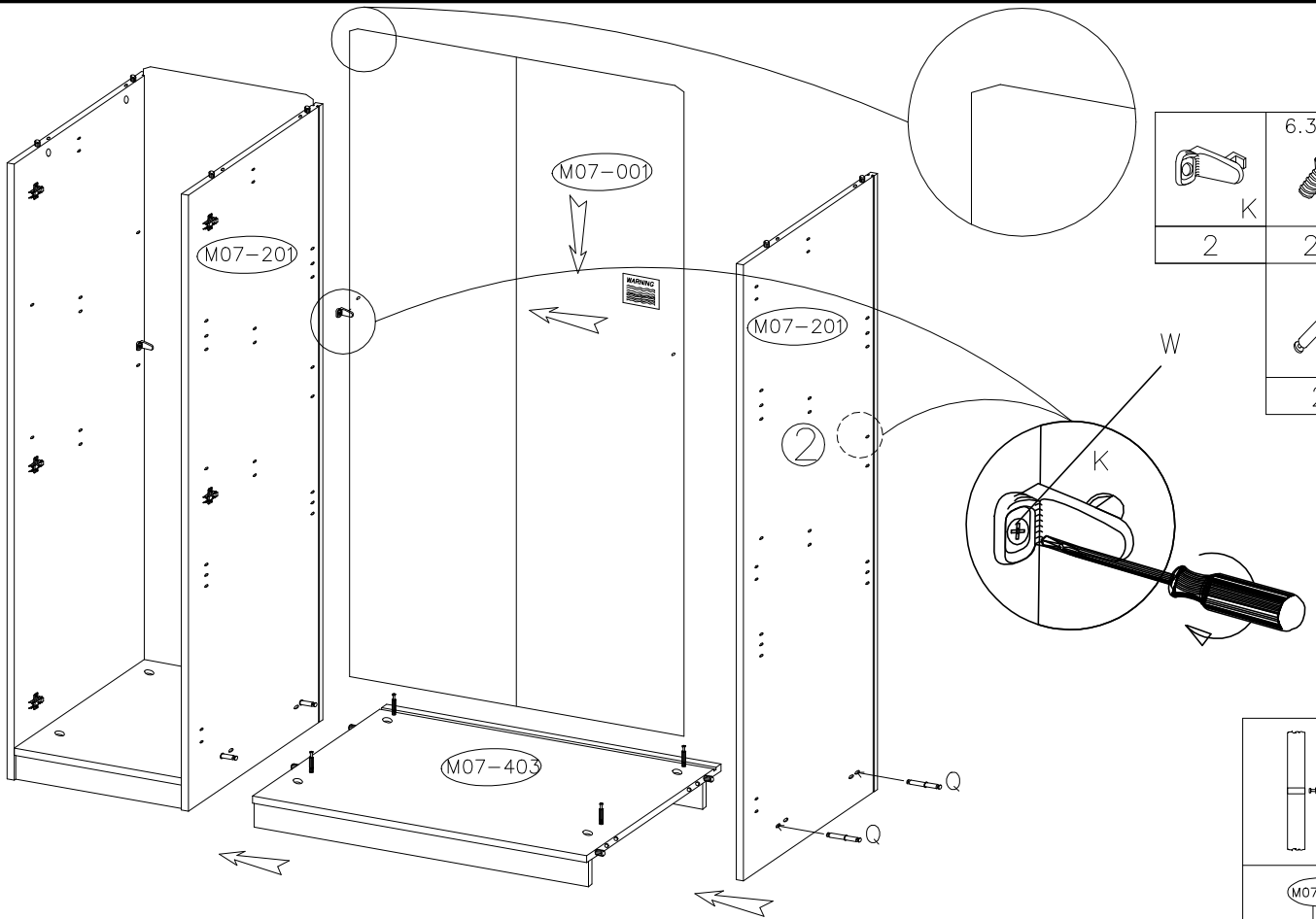

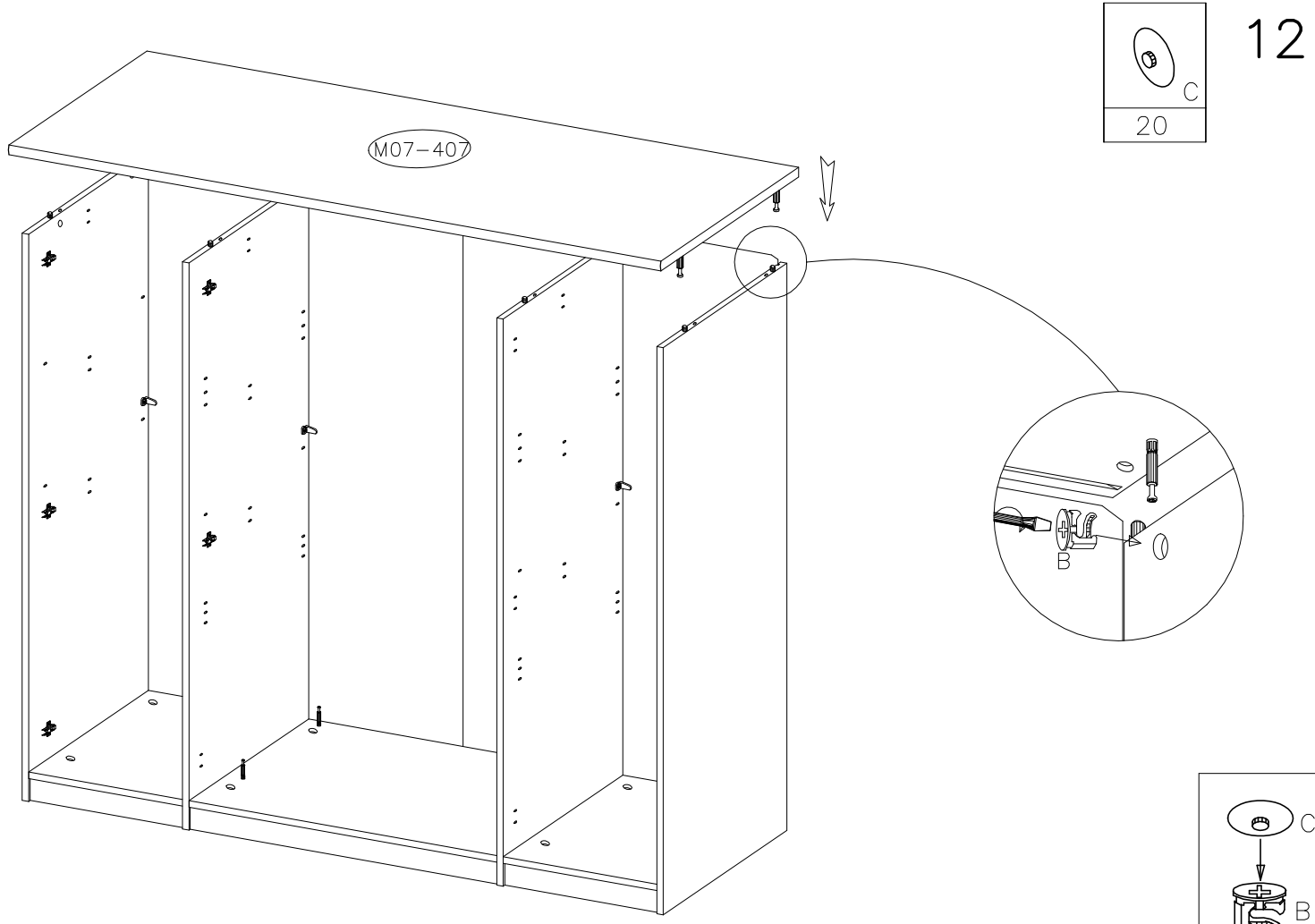
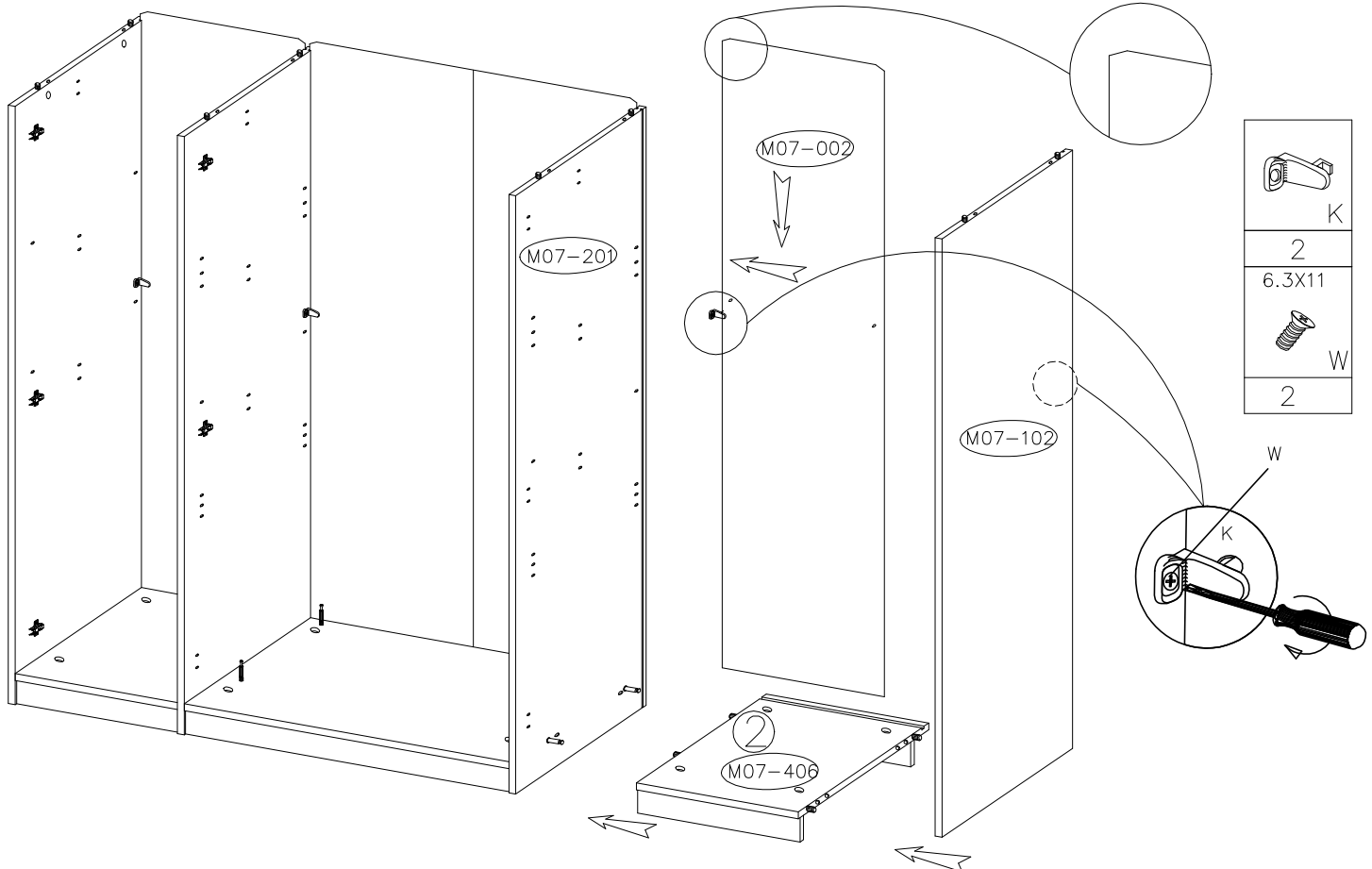
	6.3X11	
K		W
2	2	
		
		2

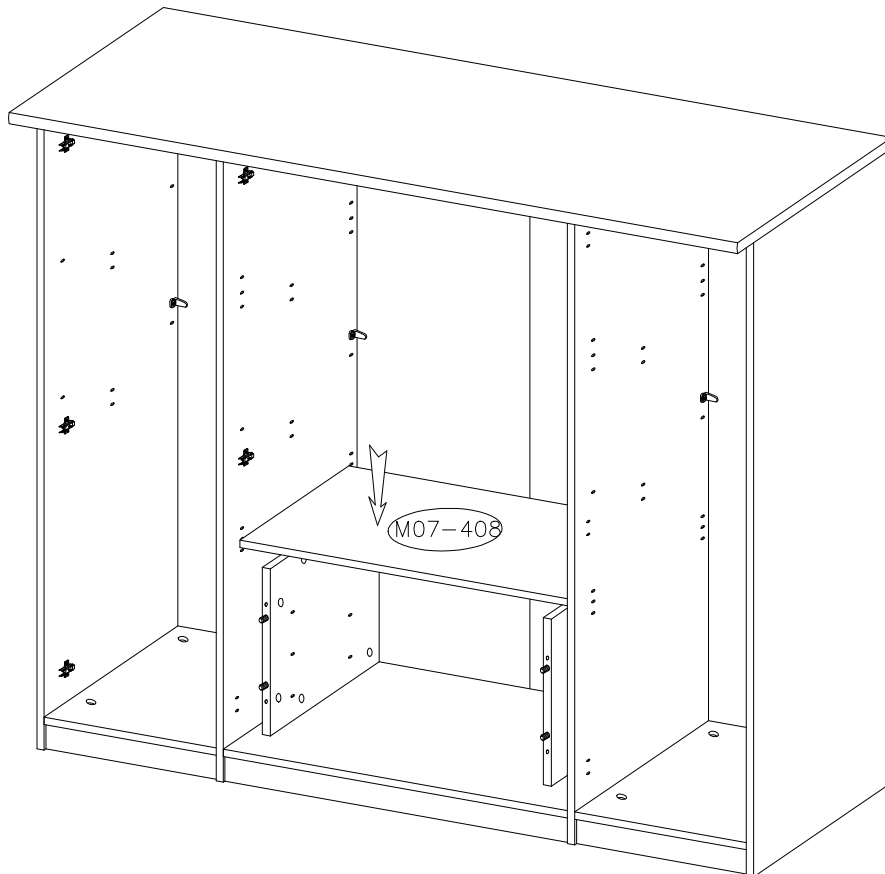
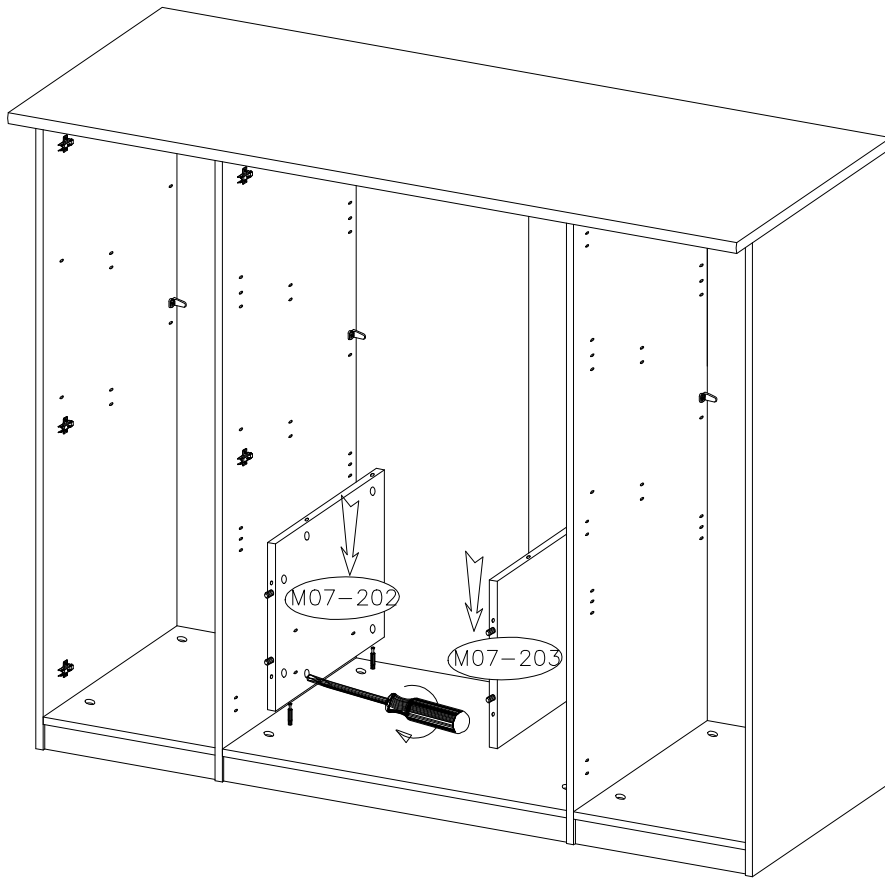

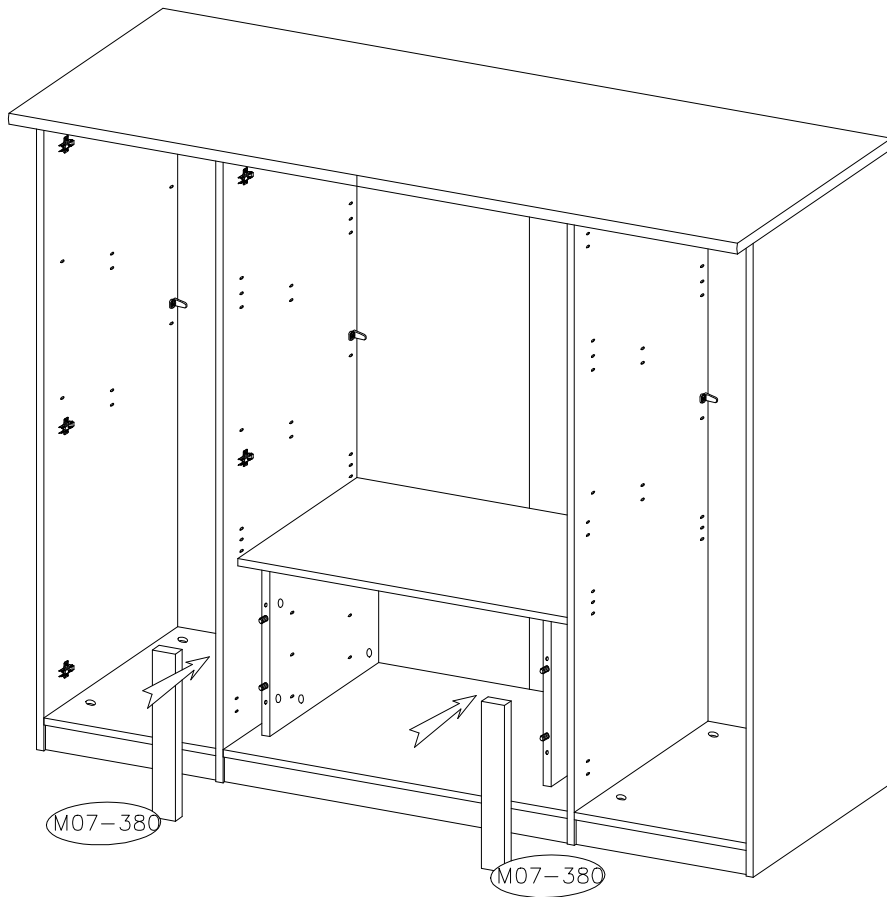



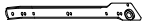



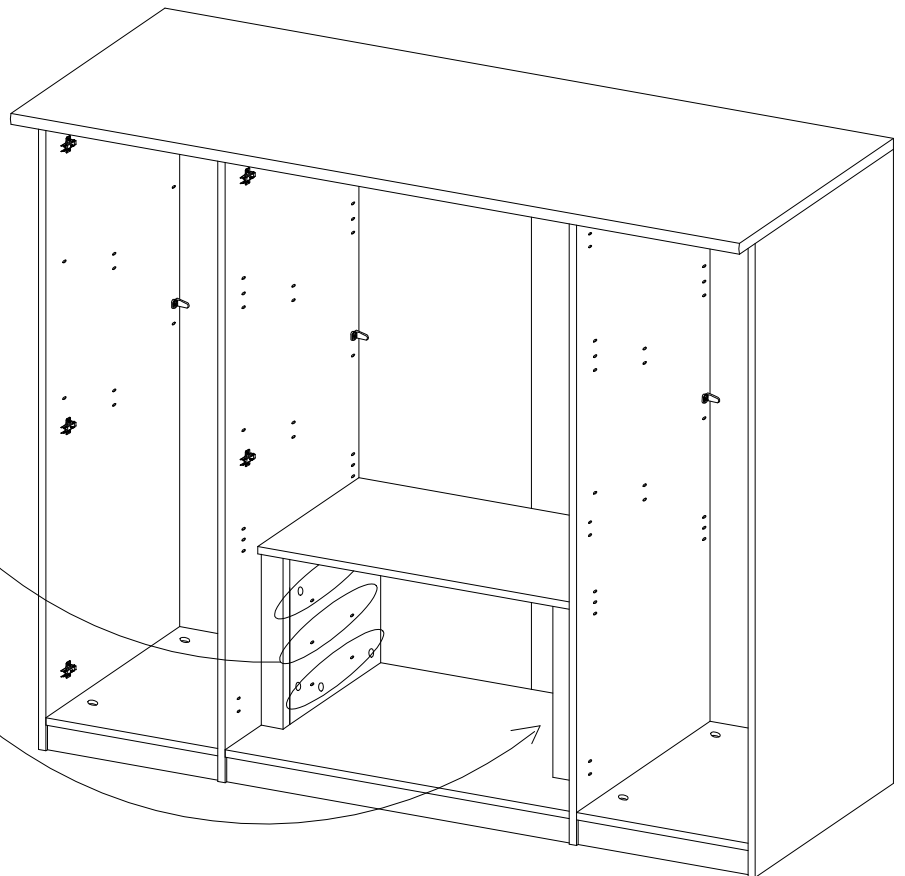
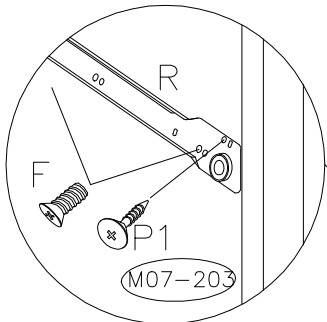
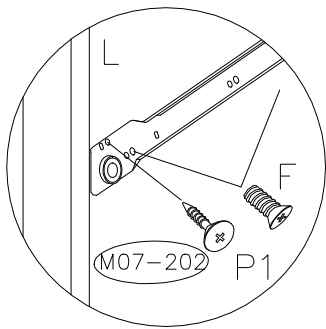

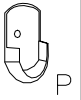

6.3X13 	3.0X15 	 R  L
12	6 P1	3 KPL

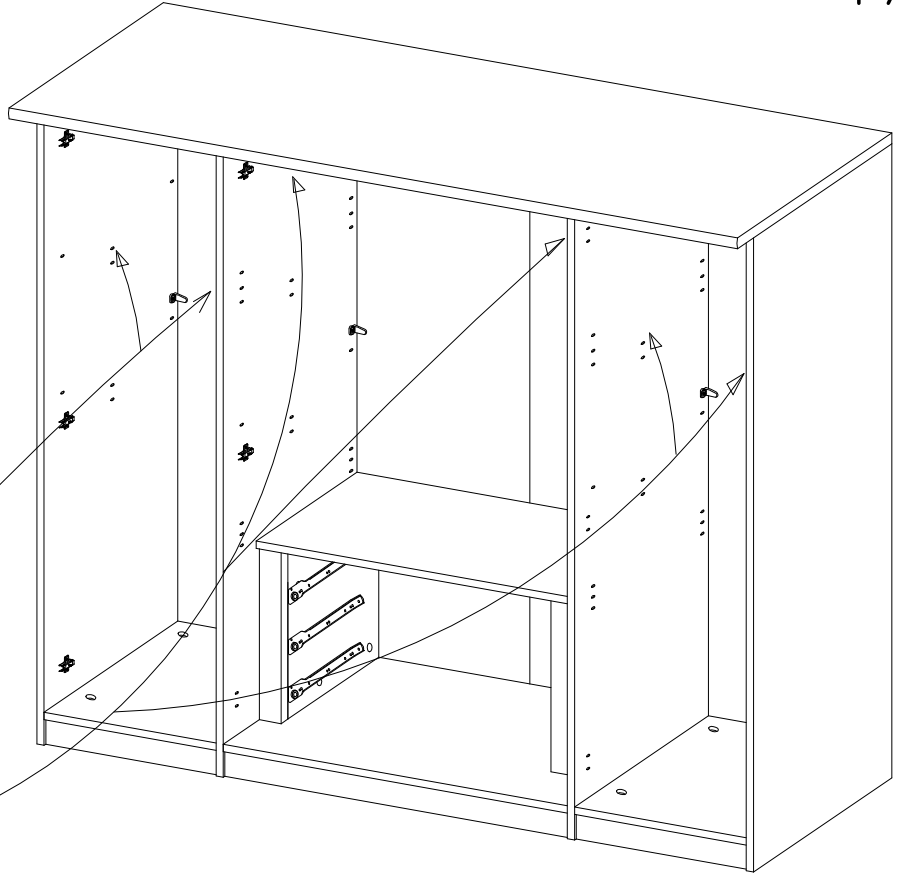
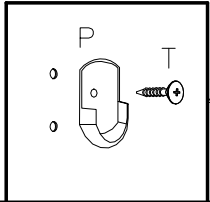
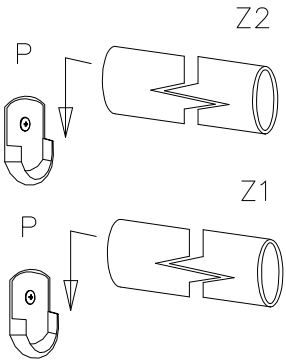

L-773		3.0X13	L-375
			
Z1	P	T	Z2
1	6	6	2





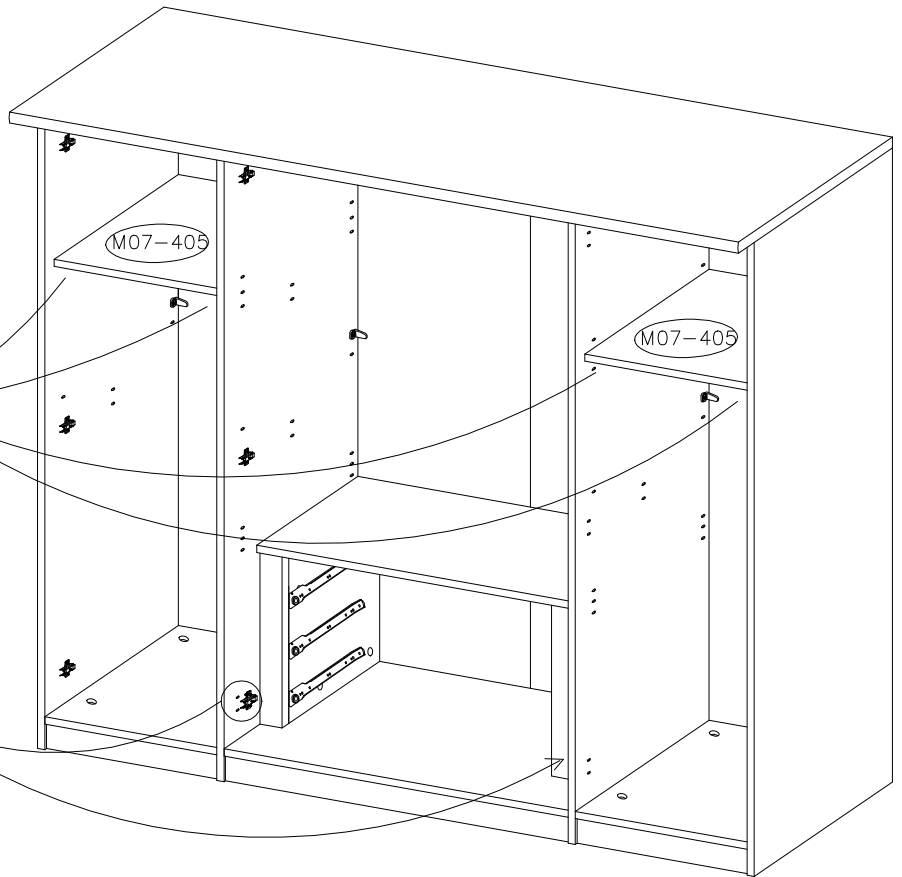
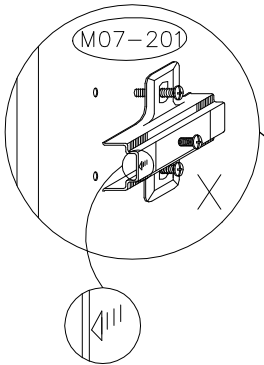
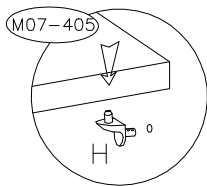

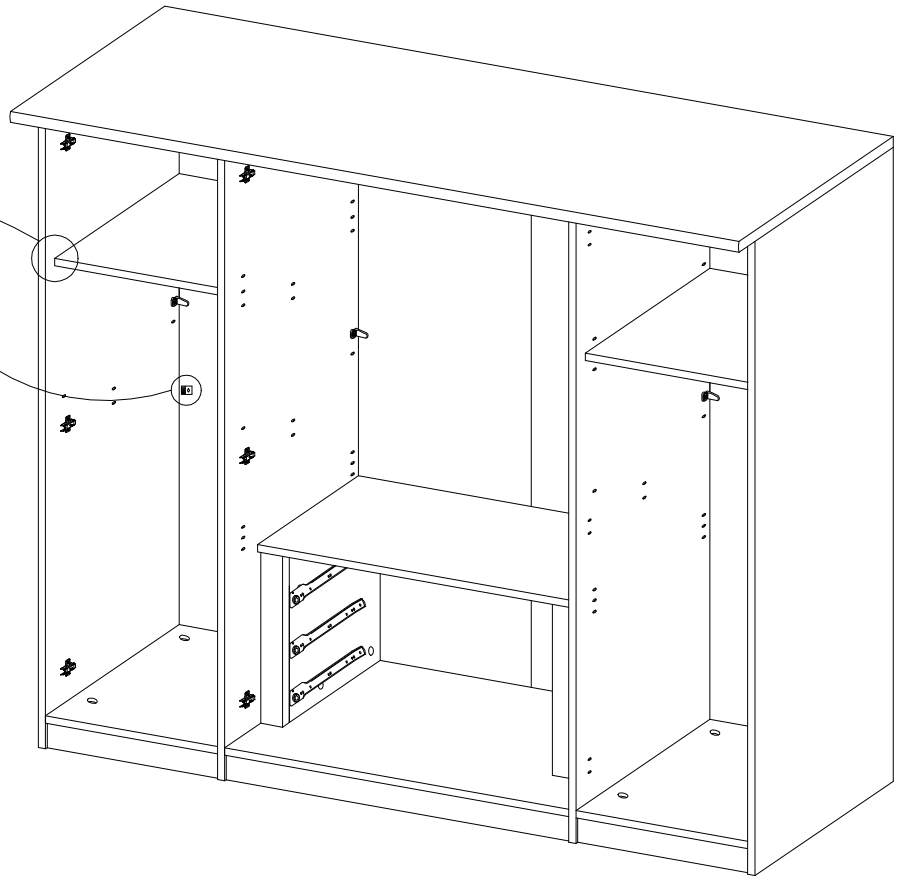
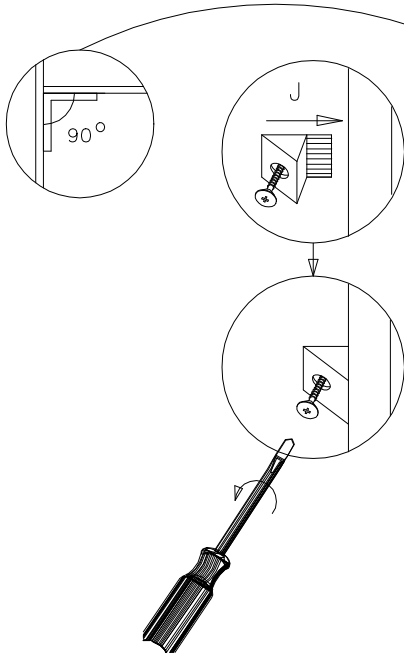
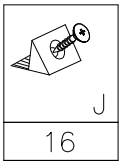

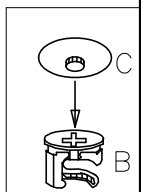
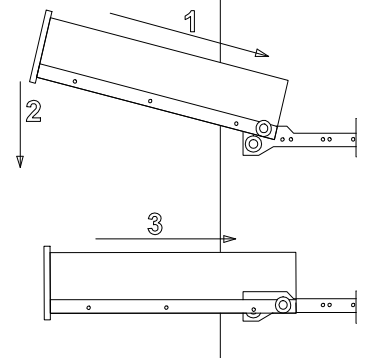
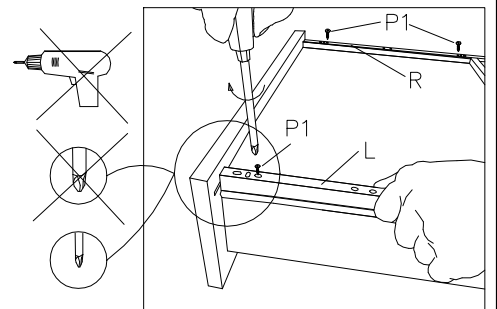
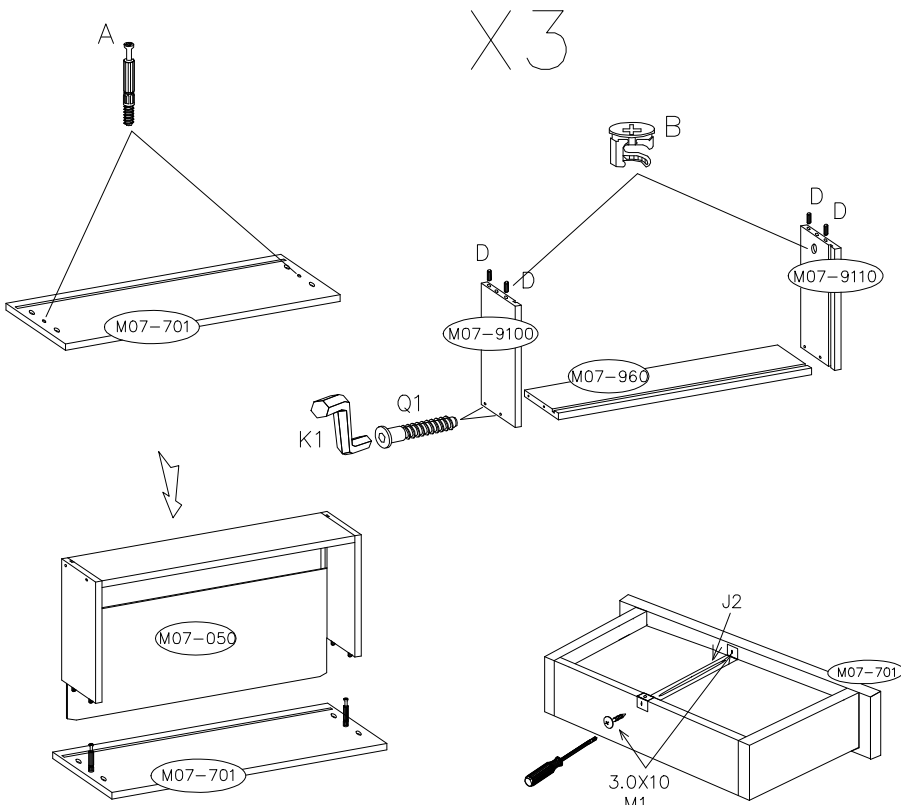

	
H	X
8	2





					3mm					
12	6	6	3	1		6	12	12	3 KPL	6



3.5X30  E1	M4.0X28  G1	 H1	6.3X13  F	M4.0X40  G	 O	 U
4	2	2	24	4	12	3

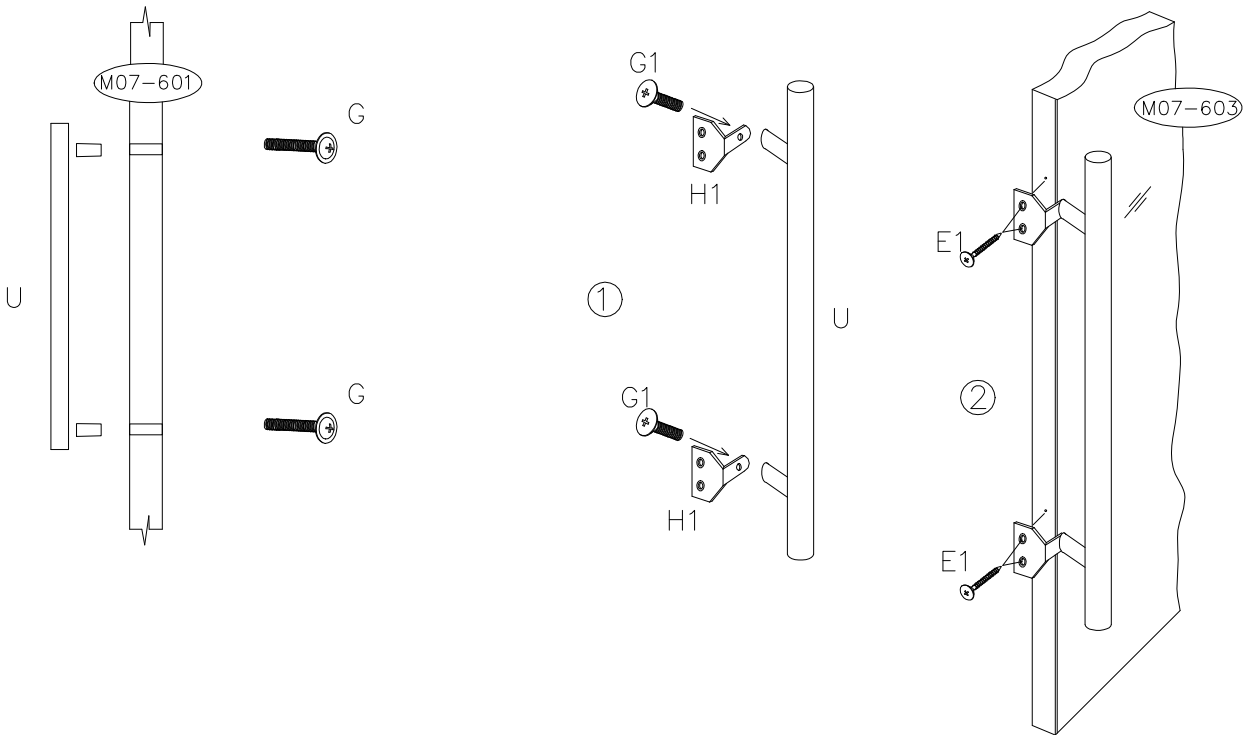
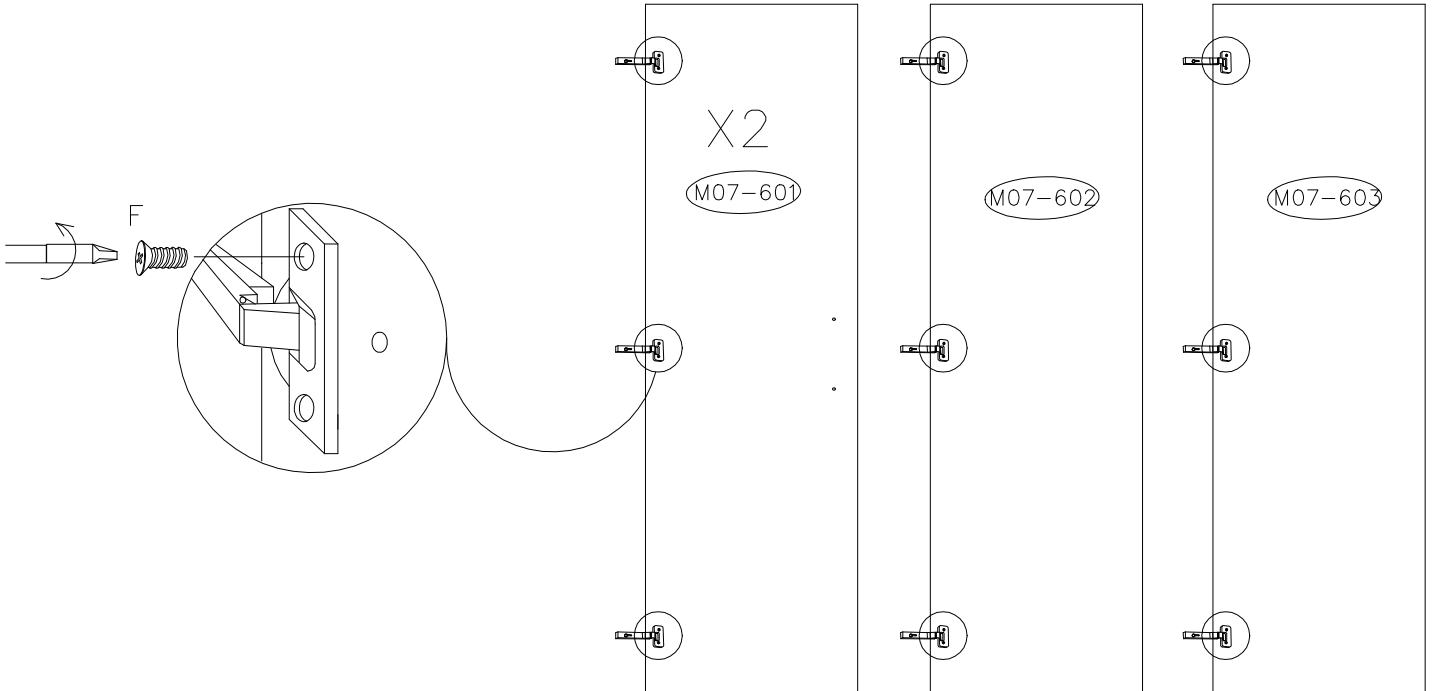

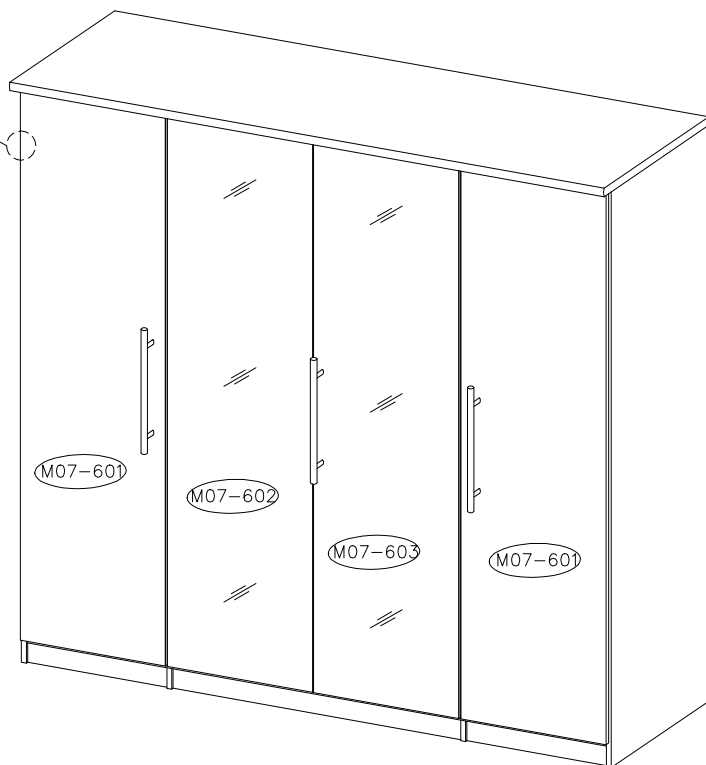
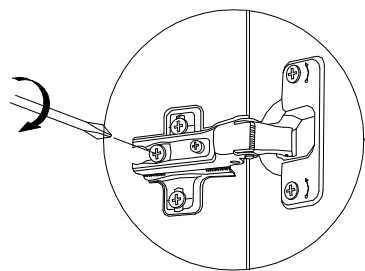

- F** Mettre la porte (égaliser les gonds)
- I** Regolare la porta (livellare le parentesi)
- D** Turen einstellen (Scharniere justieren)
- GB** Adjusting the doors (adjusting the hinges)
- NL** Deuren instellen (scharnieren afstellen)
- PL** Nastawic drzwi (wyrownac zawiasy)
- TR** Kapilarin ayarlanmasi (menteşelerin seviye ayari)
- RU** Регулировка дверей (регулировка шарнира)
- RO** Ajustați ușa (aliniati balamalele)
- CZ** Seřid'te dveře (vyrovnejte závěsy)
- SK** Zrad'te dvere (vyrovnajte závěsy)
- HU** Állítsa be az ajtót (igazítsa be a zsanérokot)

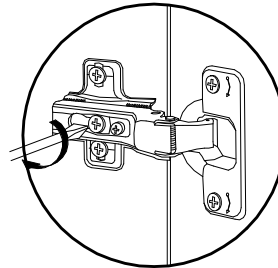
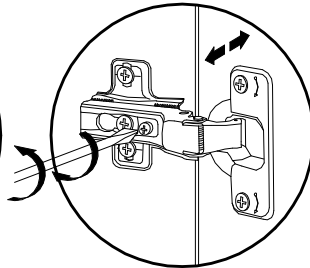
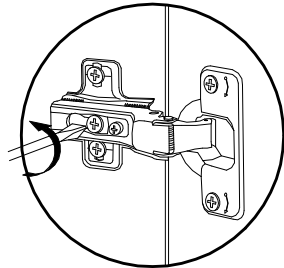
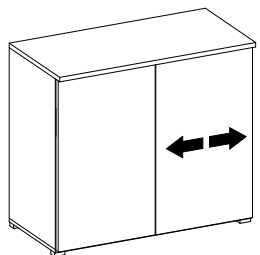
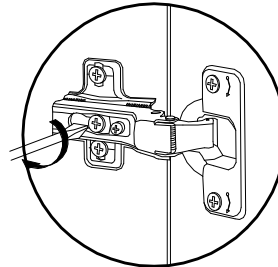
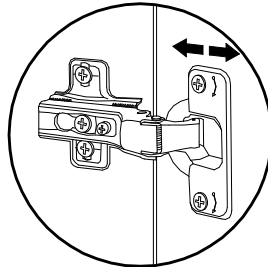
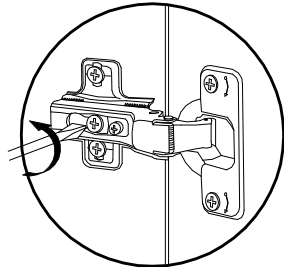
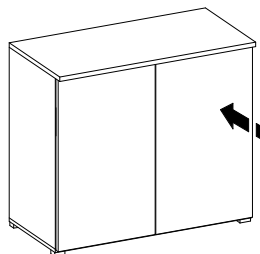
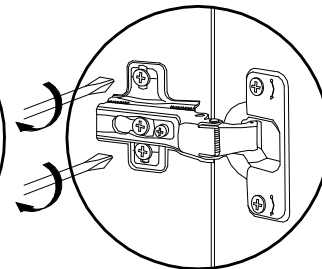
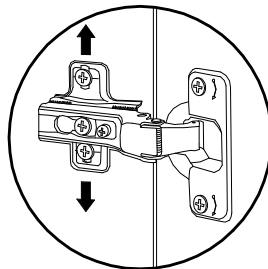
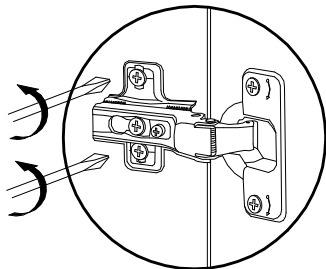
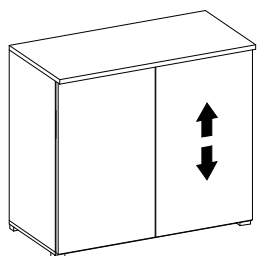

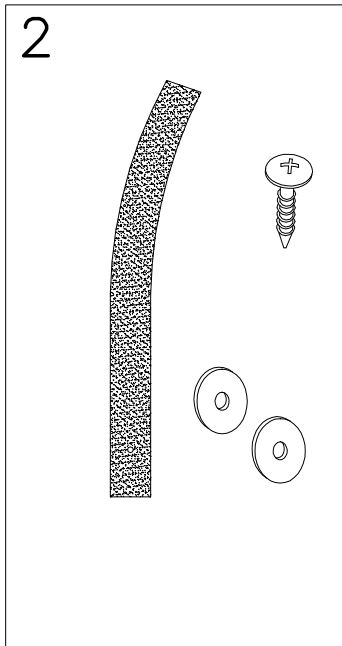

! Uwaga • Upozornini • Achtung • Attention • Caution • Figyelem ! ! Attenzione • Opgelet • Внимание • Atentie • Upozornenie • Dikkat !	
PL	Mocowanie do ściany jest jednocześnie zabezpieczeniem przed przewróceniem – koniecznie zamontować!
CZ	Do některých rodzajův ťian koniecznie zastoťowaċ ťpeciálne koťki mocujice. Montáž na ťtĕnu ťlouží jako ochrana proti pĕvrhnutí – bezpodmĕneċnĕ ůmĕťte! U nĕkterých typů ťtĕn může být zapoťřebí ťpeciální hmoždinka!
D	Wandbefestigung dient als Kippschutz – unbedingt anbringen! Bei einigen Wandtypen kann ein Spezialdübel erforderlich sein!
GB	The wall fastening serves to prevent tipping – be absolutely sure to mount it! For certain wall types, a special wall plug may be necessary!
FR	La fixation murale sert de protection contre le basculement – à installer impérativement ! Pour certains types de murs il faut des chevilles spéciales !
NL	Bevestiging aan de muur dient als kantelbescherming – zeker en vast bevestigen! Bij enkele muurtypes is een speciale plug misschien vereist!
IT	Il fissaggio alla parete serve da protezione anti-ribaltamento – attaccarla assolutamente! Per alcune strutture di parete può essere necessario un tassello speciale!
HU	A termékét a falhoz kel rögzíténi, különben az felborulhat! Egyes faltípusoknál speciális tiplít kell használni!
RU	Обязательно установите крепление на стене во избежание опрокидывания! Для некоторых типов стен может потребоваться специальный дюбель!
RO	Sistemul de fixare la perete serve, te ca protecťie la rĕsturnare – de montat obligatoriu!
SK	Pre niektoré druhy ťtien může být poťrebná ťpeciálna hmoždinka!
TR	Duvardaki sabitleme, devrilmeye karťı bir emniyet tedbiridir ve mutlaka monte edilmelidir! Bazı duvar tiplerinde bunun için özel bir dübel gerekli olabilir!

