

DOUGLAS 23

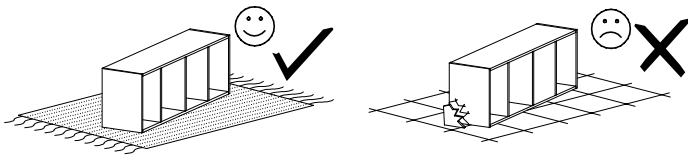

Narzędzia potrzebne do montażu

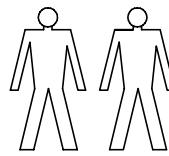
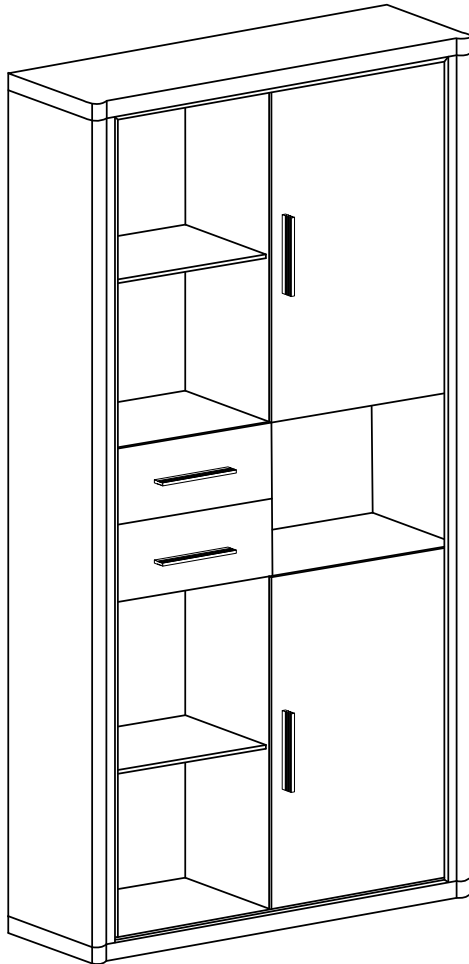
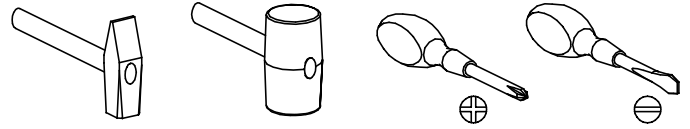

Nr	D[mm]	S[mm]	G[mm]	Ilość
1	970	422	16	1
2	970	422	16	1
3	1810	450	48	1
4	1810	450	48	1
5	1810	405	16	1
6	405	370	16	1
7	460	405	16	4
8	930	25	20	2
9	1810	100	32	2
10	1835	480	2,5	2
11	460	380	16	4
12	400	150	16	4
13	312	150	16	2
14	383	190	16	2
15	405	334	2,5	2
16	700	383	16	2

UWAGA !!!

MONTOWANIE USZKODZONYCH
ELEMENTÓW POWODUJE UTRATĘ
GWARANCJI

W przypadku reklamacji proszę podać numer pakowacza znajdujący się na kartonie.

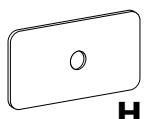

H - 15 St.

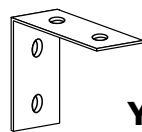

Y - 1 St.

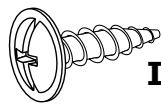

I - 2 St.
3,5x16 mm



X1 - 24 St.



X2 - 8 St.

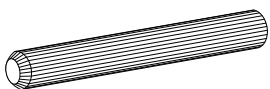

R - 4 St.

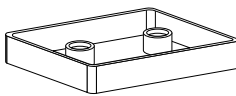

A - 4 St.

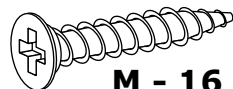

M - 16 St.
3,9x25 mm

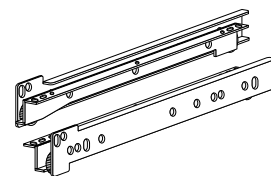

T - 2 Kpl.



F - 8 St.

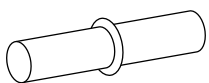

P - 16 St.

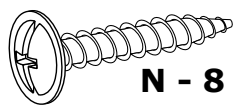

N - 8 St.
4x27 mm

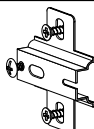

C - 4 St.

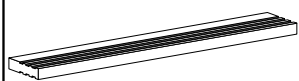

U - 4 St.

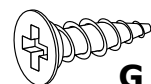

G - 23 St.
3,5x16 mm

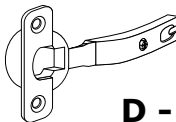

D - 4 St.

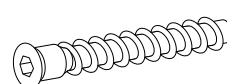

W - 8 St.

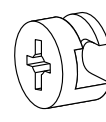

L - 24 St.



E - 80 St.

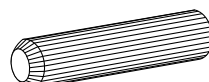

B - 24 St.

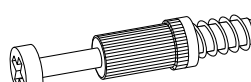

K - 24 St.

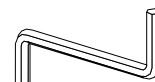

Z - 1 St.

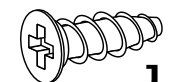

J - 8 St.
5x13 mm

I

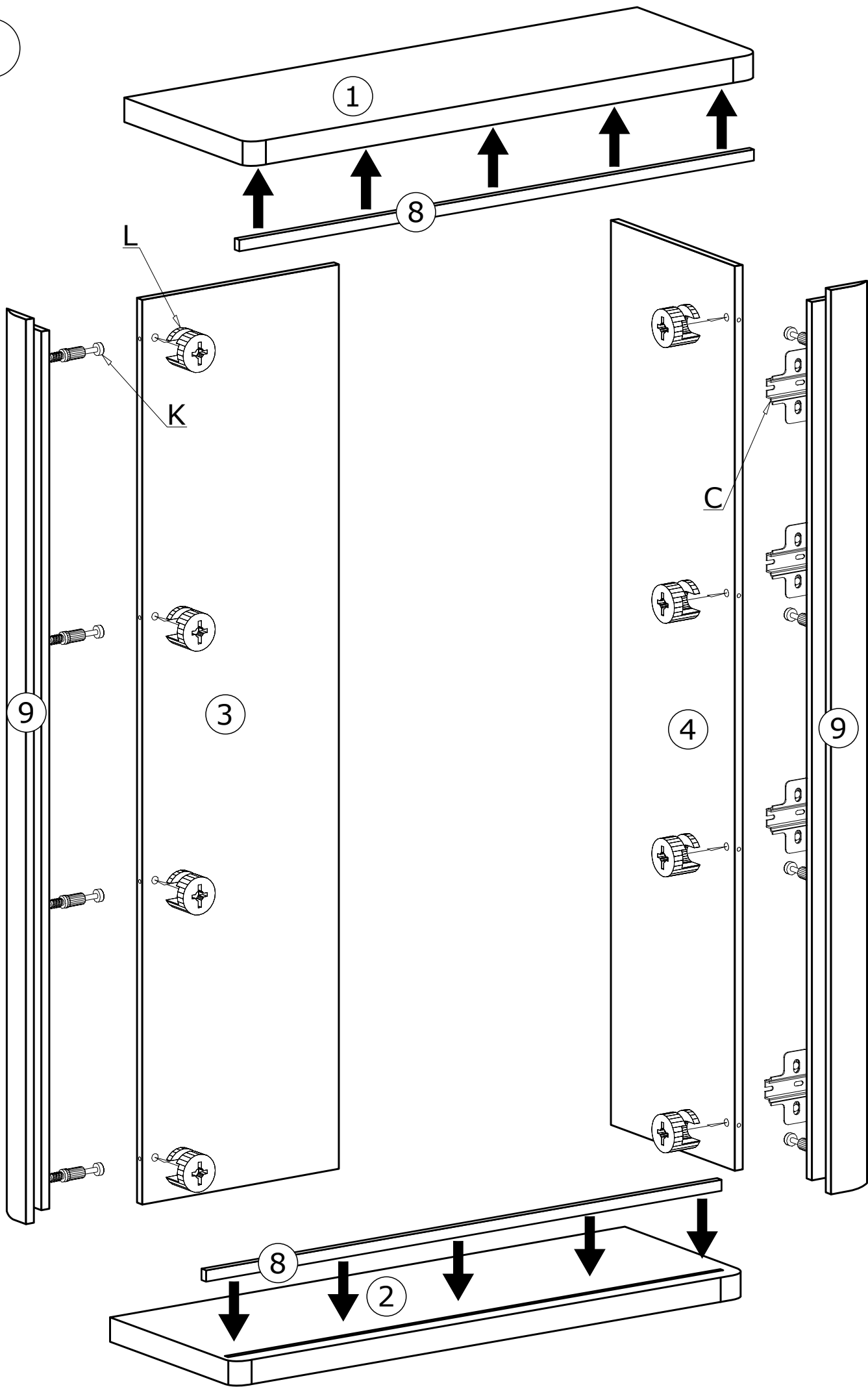

II

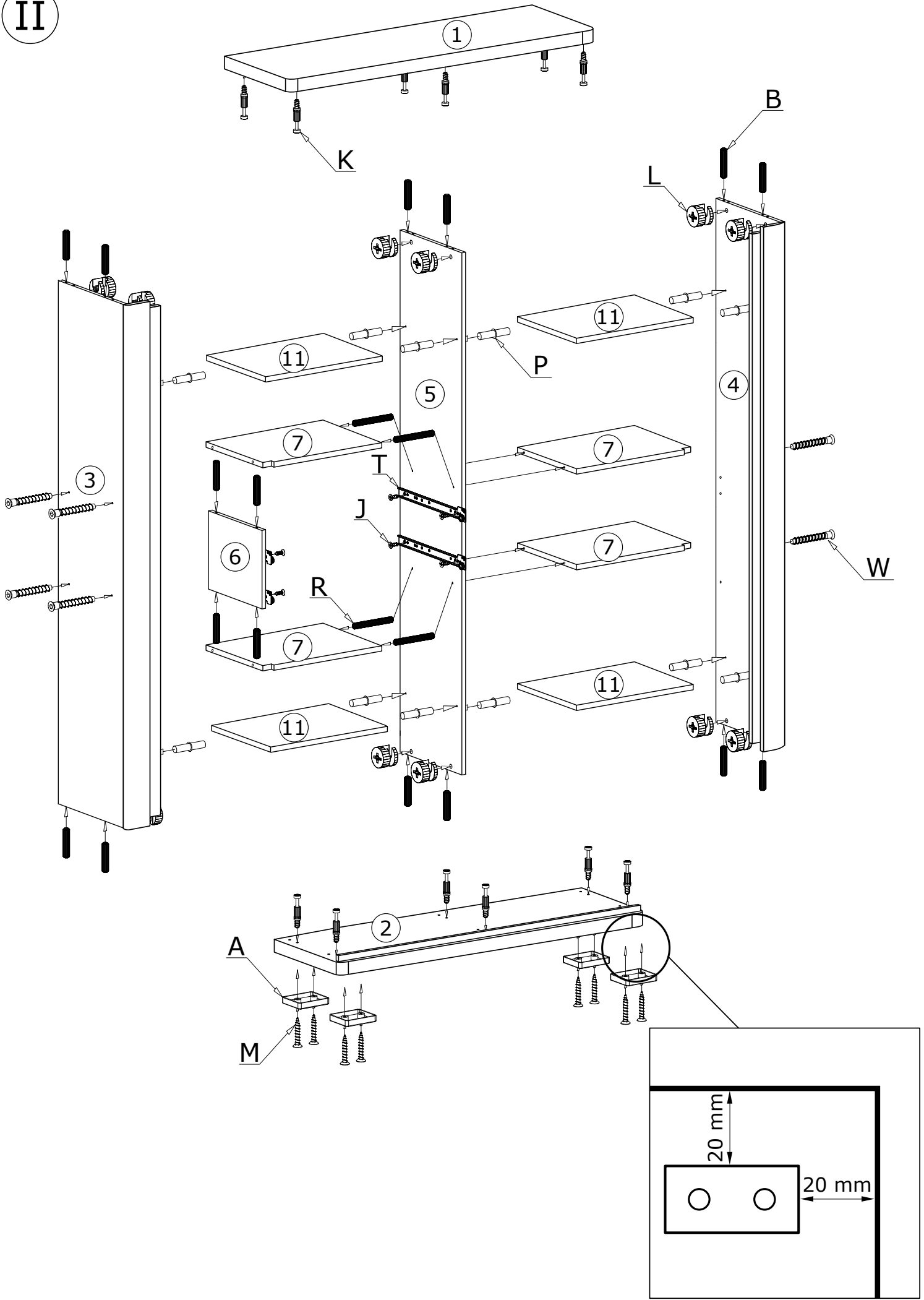

III

60X

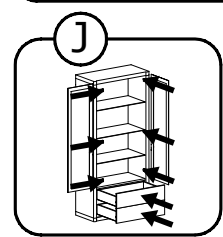
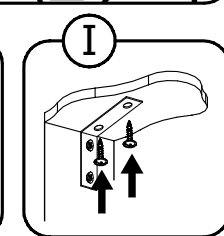
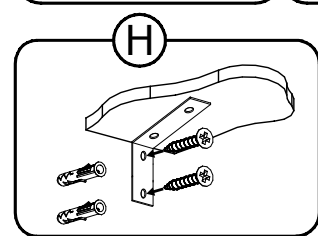
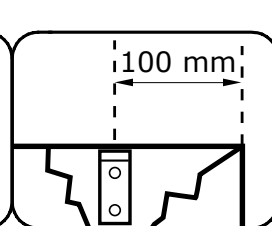
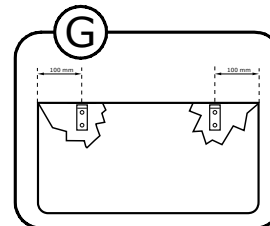
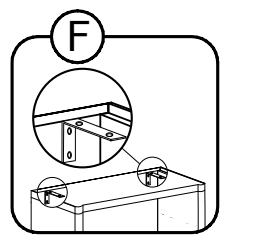
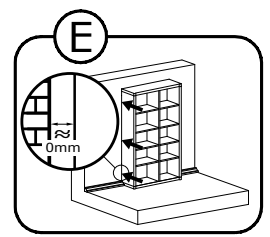
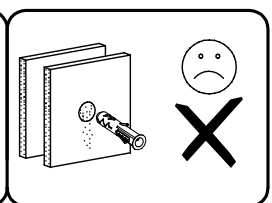
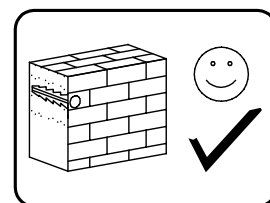
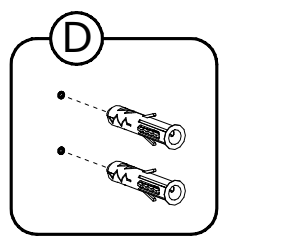
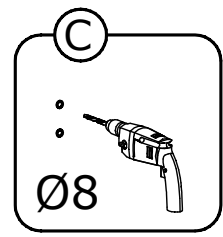
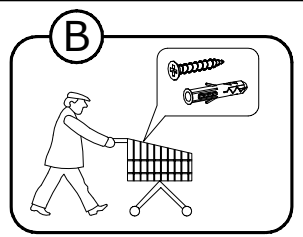
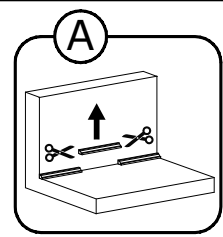
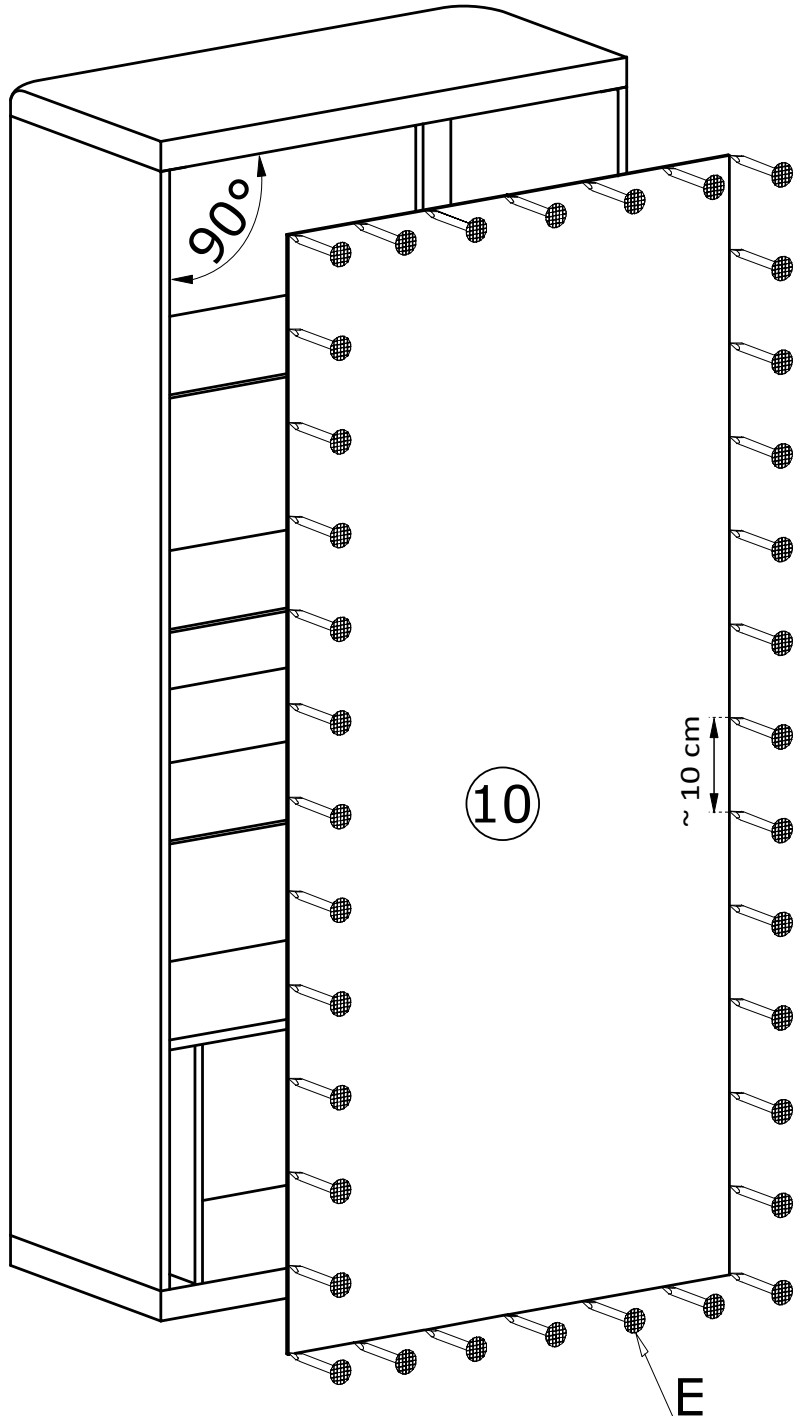

IV

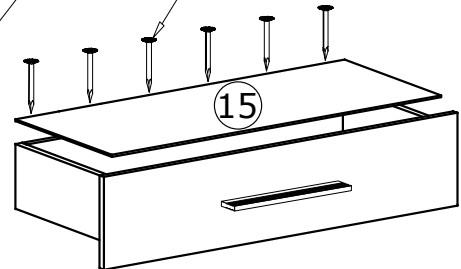
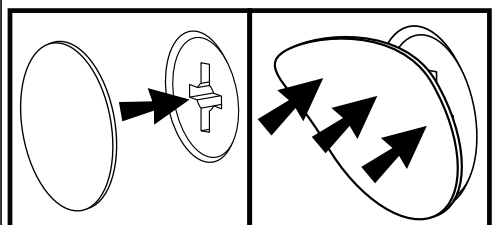
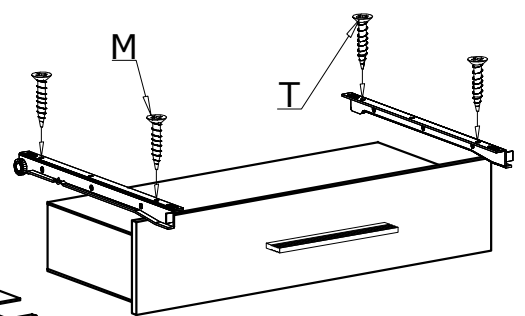
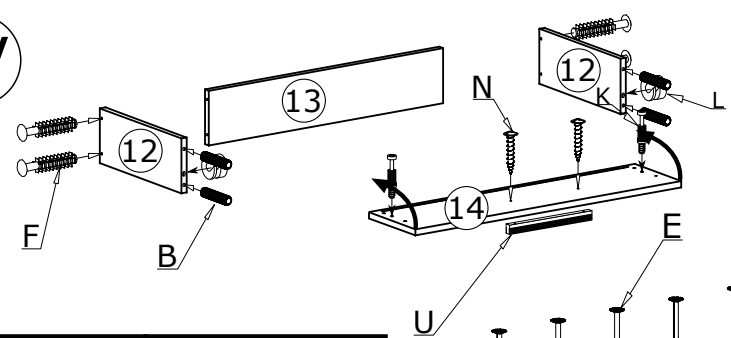

V

