

DOUGLAS 12



Narzędzia potrzebne do montażu









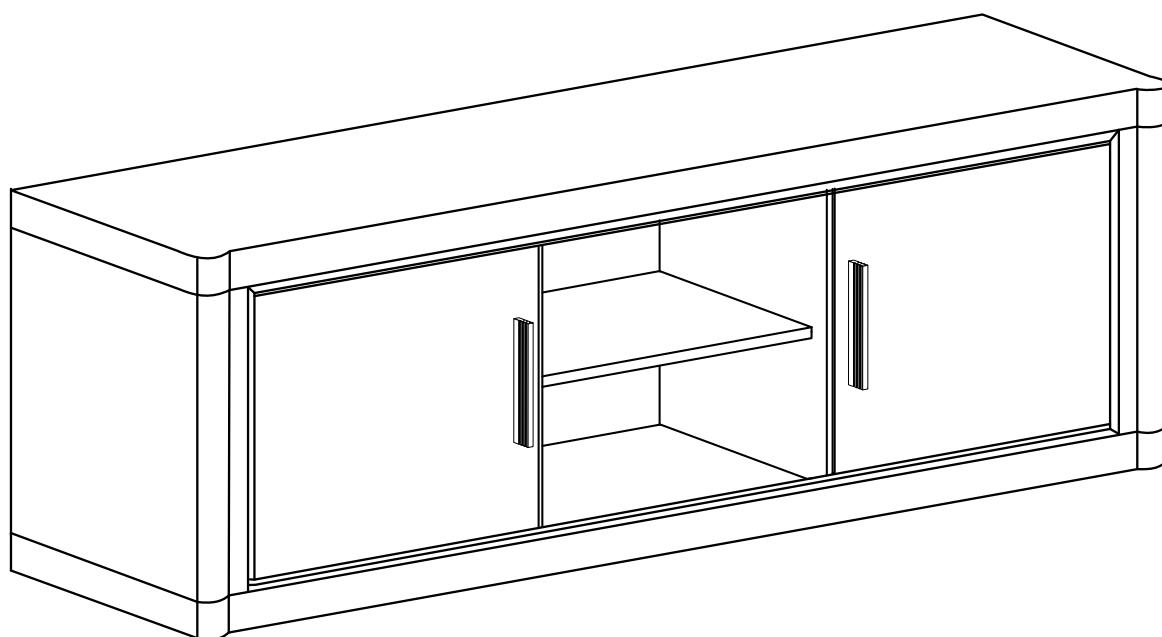

UWAGA !!!

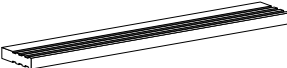
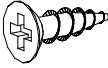
MONTOWANIE USZKODZONYCH
ELEMENTÓW POWODUJE UTRATĘ
GWARANCJI

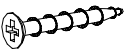
Nr	D[mm]	S[mm]	G[mm]	Ilość
1	1370	450	48	1
2	1370	450	48	1
3	1330	25	16	2
4	420	422	16	1
5	420	422	16	1
6	420	100	32	1
7	420	100	32	1
8	452	405	16	1
9	452	405	16	1
10	442	380	16	2
11	418	380	16	1
12	1360	475	2,5	1
13	450	380	16	1
14	450	380	16	1

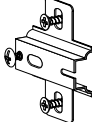
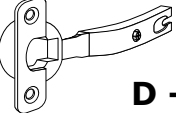
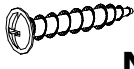

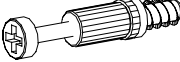
W przypadku reklamacji proszę podać numer pakowacza znajdujący się na kartonie.

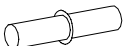
		 U - 2 St.	 G - 8 St. 3,5x16 mm	 L - 20 St.
 R - 12 St. 3x30 mm	 E - 40 St.	 C - 4 St.	 D - 4 St.	 N - 4 St. 4x30 mm
 A - 6 St.	 B - 16 St.	 K - 20 St.	 Z - 1 St.	 P - 12 St.

I

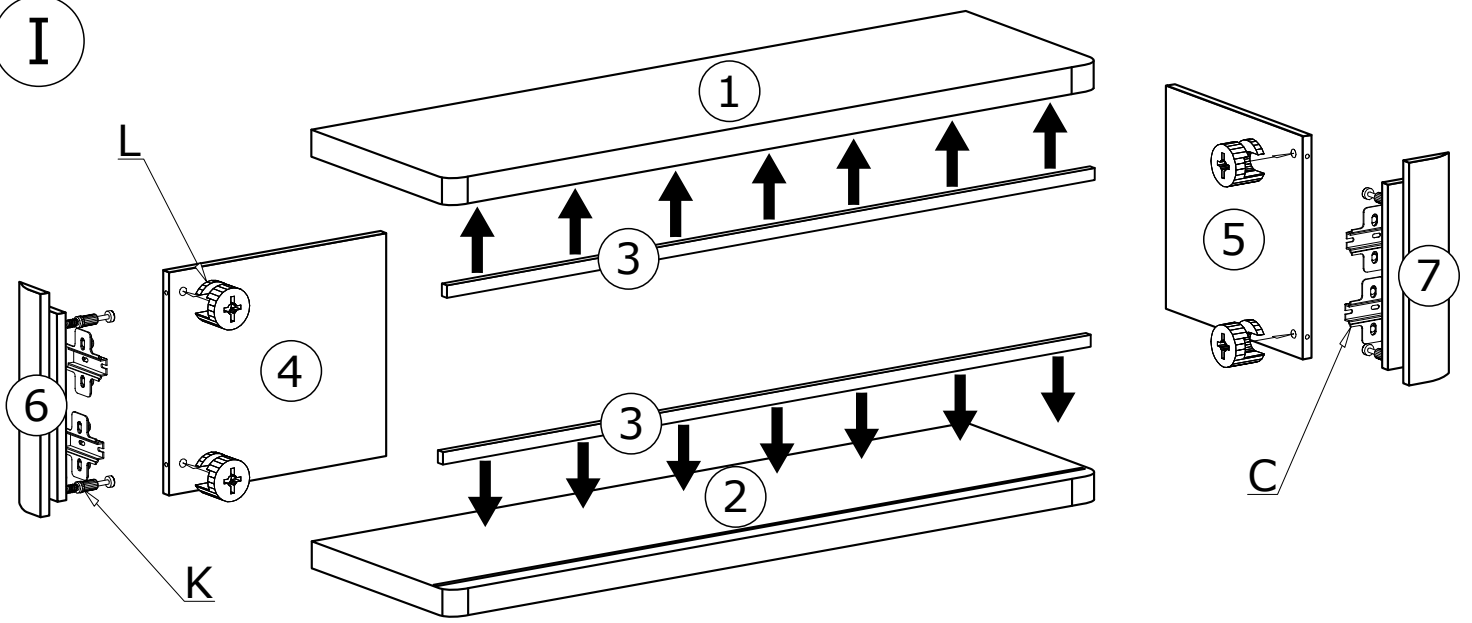

II

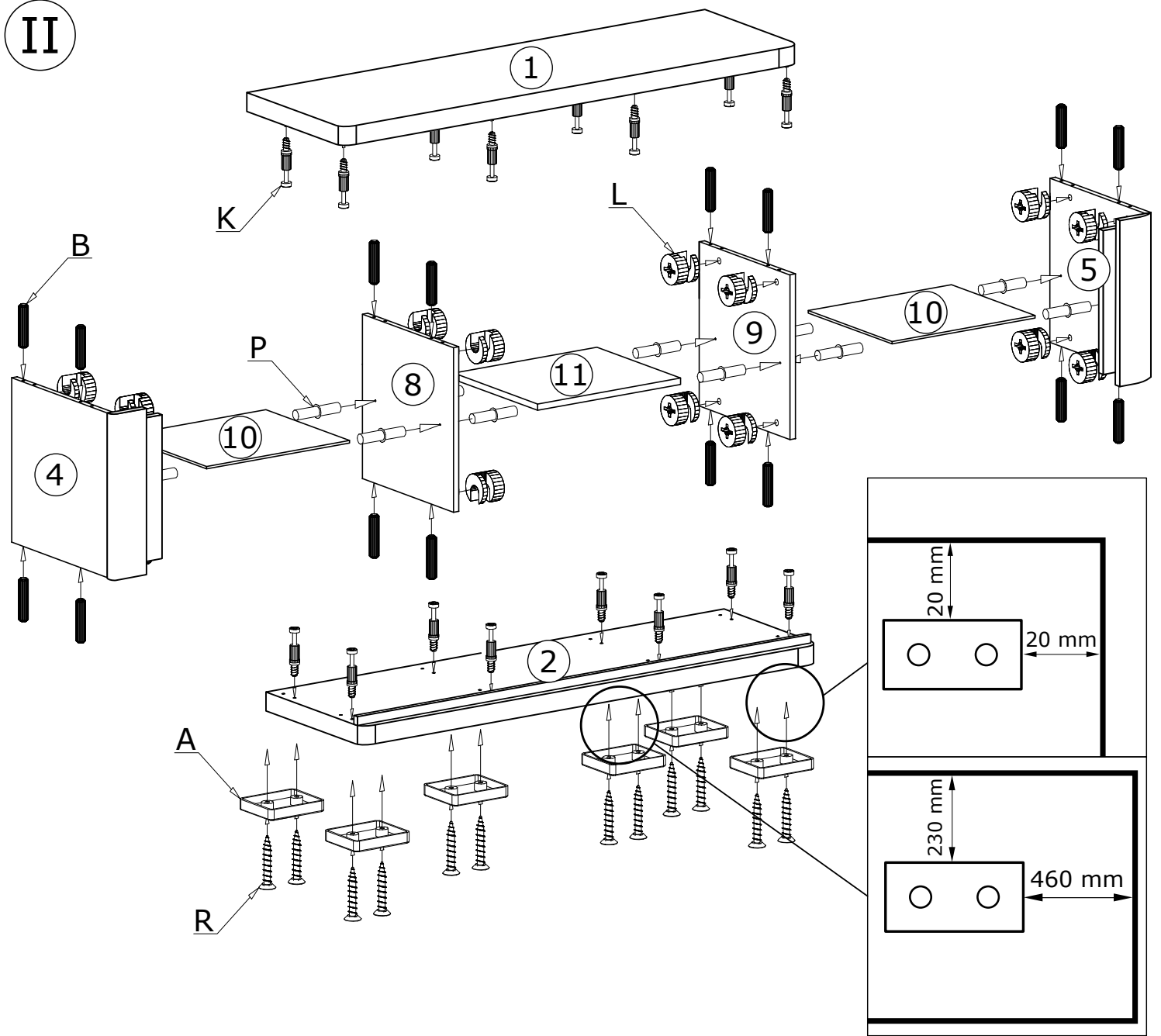

III

40X 

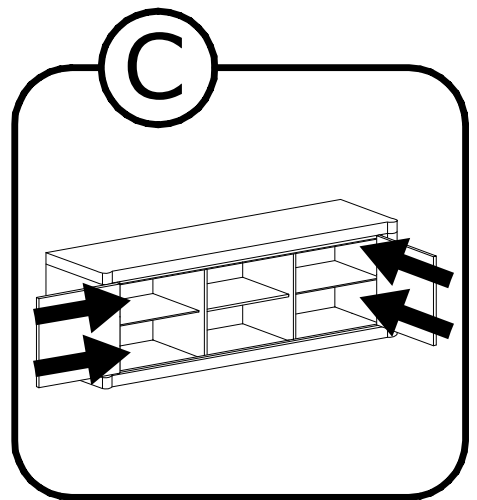
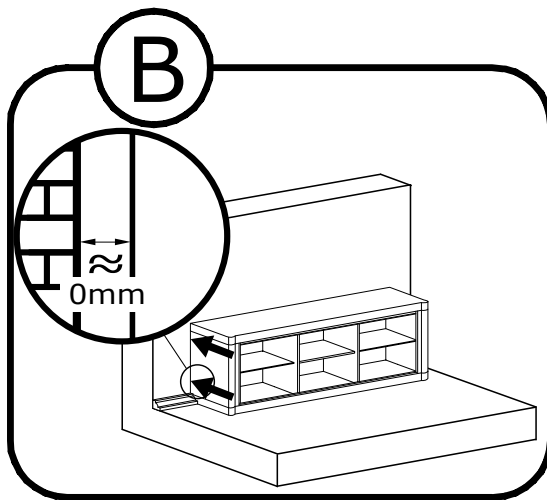
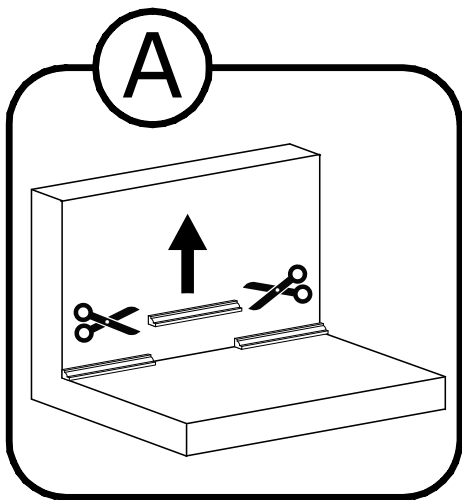
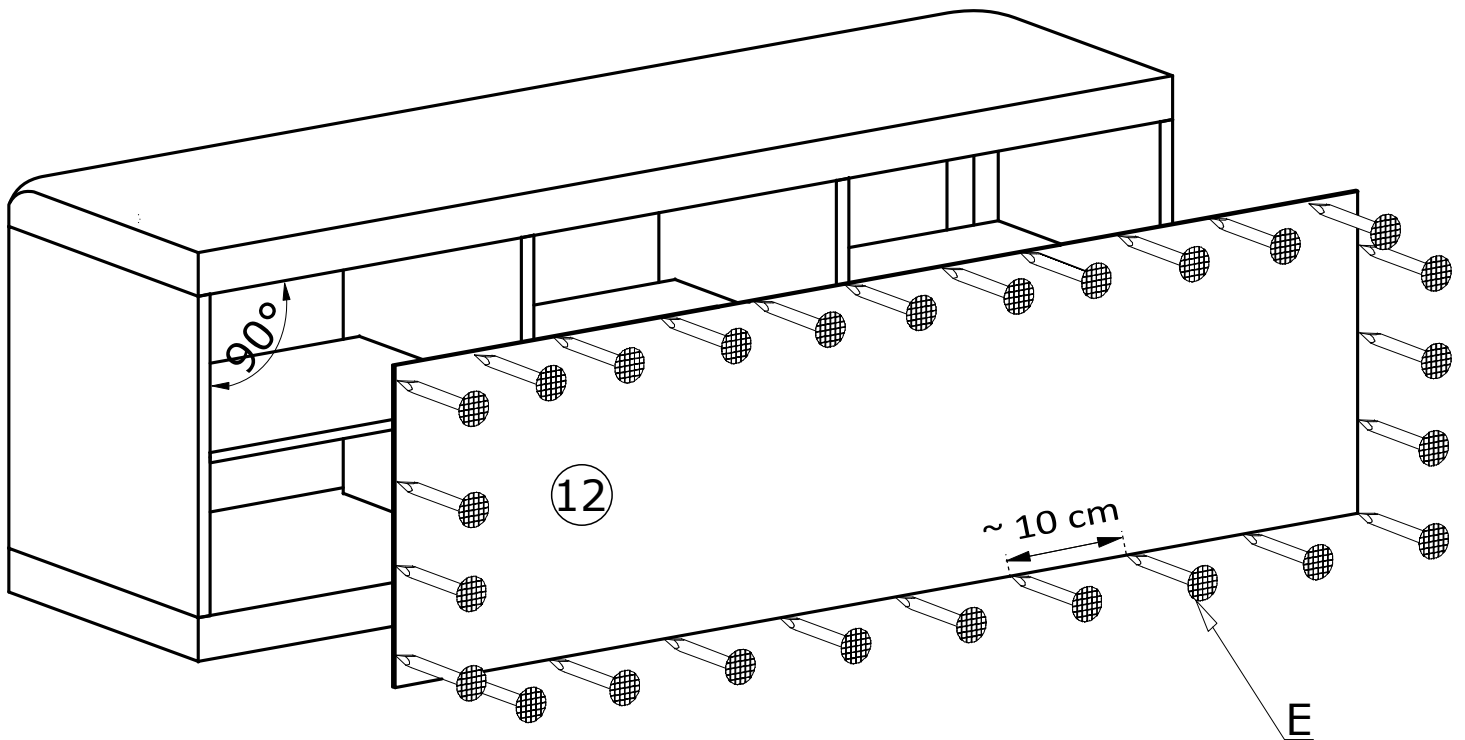

IV

