

# KOMODA RIVEN 100

**PL> INSTRUKCJA MONTAŻU**  
**D >MONTAGEANLEITUNG**  
**GB>ASSEMBLY INSTRUCTIONS**  
**NL>HANDLEIDING VOOR DE MONTAGE**  
**F >MODEL D'EMPLOI**  
**CZ>NÁVOD NA MONTÁŽI**  
**SK>NÁVOD NA MONTÁŽI**

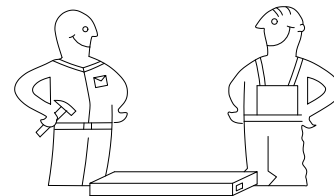

Czas montażu 120 minut  
 Montagezeit 120 minuten  
 Time to assemble 120 minutes  
 Montagetijd 120 minuten  
 Temps de montage 120 minutes

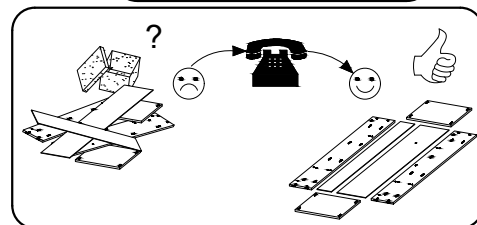
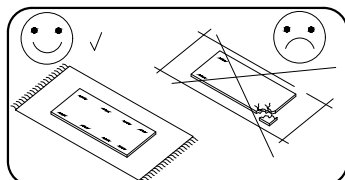
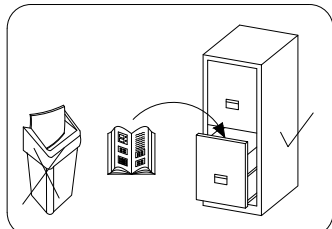
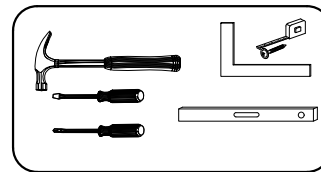

**! Uwaga / Achtung / Caution / Opgelet / Attention / Upozornini / Upozornenie !**

**PL>**Czyszczenie należy wykonać wyłącznie za pomocą ściereczki lub lekko nawilżonego ręcznika.  
 Nie stosować środków czyszczących do szorowania.

Szanowny kliencie, jeśli podczas montażu stwierdzisz uszkodzenie lub brak części, proszę podaj jej kod alfanumeryczny lub zaznacz ją na instrukcji montażu i prześlij wraz z protokołem reklamacyjnym

**D >**Bitte nur mit einem Staubtuch oder leicht feuchtem Lappen reinigen. Keine scheuerenden Putzmittel verwenden.

Sehr geehrter Kunde, sollte ein Teil fehlen oder beschädigt sein, kreuzen sie dies bitte deutlich auf der Montageanleitung an und schicken sie die Montageanleitung mit ein.

**GB>**Please only clean with a duster or a damp cloth. Do not use any abrasive cleaners.

Dear customer, should there be any piece missing or damaged, kindly mark this piece clearly on the attached assembly instructions and return them to us.

**NL>**Reinig alleen met een stofdoek of een lichtjes vochtige doek. Gebruik geen schurende poetsmiddelen.

Geachte klant, in het geval van beschadiging of ontbrekende onderdelen tijdens de montage, gelieve de alfanumerieke code in de montagehandleiding te vermelden of te markeren en samen met het klachtenprotocol mee te sturen

**F >**Le nettoyage se fait uniquement à l'aide d'un torchon ou d'une serviette légèrement mouillée.

Cher client, en cas de dommages ou de pièces manquantes lors du montage, veuillez fournir ou marquer le code alphanumérique dans le manuel de montage et l'envoyer avec le protocole de réclamation

**CZ>**Vážený zákazníku, pokud během montáže zjistíte poškození, uveďte prosím jeho kód nebo jej označte na pokynu a odešlete s protokolem.

**SK>**Vážený zákazník, ak počas montáže zistíte poškodenie, zadajte prosím jeho kód alebo ho označte na návode a odošlite s protokolom.

## Karta serwisowa /Service Karte /Service card /Service kaart /Carte de service

AKCESORIA / ZUBEHÖR / ACCESSORIES / ACCESSOIRES / ACCESSOIRES

|                       |             |                        |              |                        |              |             |                       |             |
|-----------------------|-------------|------------------------|--------------|------------------------|--------------|-------------|-----------------------|-------------|
| 8.0x35<br><br>D<br>12 | <br>A<br>32 | Ø15x12<br><br>B<br>32  | <br>MS<br>1  | 5.0x16<br><br>F1<br>16 | <br>S1<br>30 | <br>SC<br>2 | 4.0x30<br><br>P1<br>4 |             |
| <br>X<br>32           | <br>J<br>8  | 3.0x13<br><br>H4<br>16 | <br>WJ2<br>4 | 3.5x16<br><br>H<br>12  | <br>WJD<br>4 | <br>TP<br>4 | <br>WJG<br>4          | <br>LH<br>1 |

cm. 0. 1. 2. 3. 4. 5.

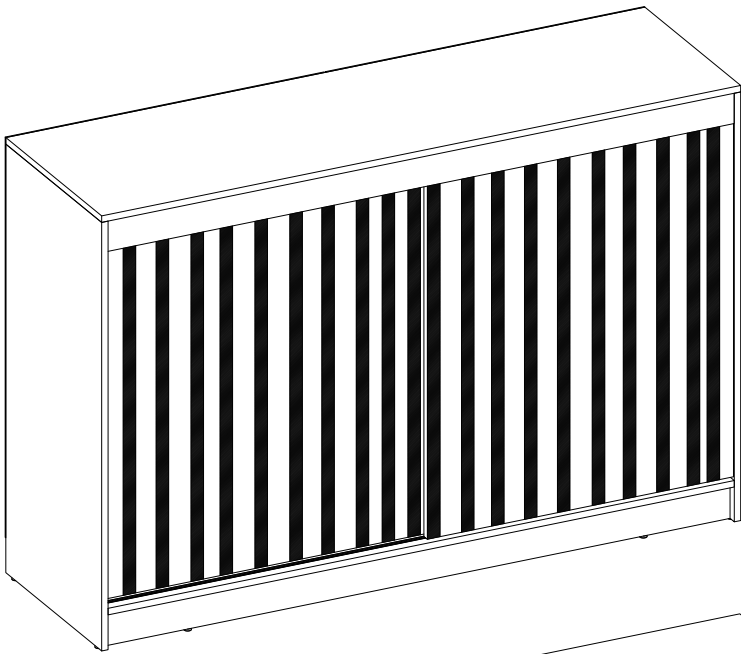

|     |   |      |     |    |
|-----|---|------|-----|----|
| 1.  | 1 | 1002 | 451 | 16 |
| 2.  | 1 | 968  | 450 | 16 |
| 3.  | 1 | 984  | 450 | 16 |
| 4.  | 1 | 984  | 450 | 16 |
| 5.  | 1 | 888  | 330 | 16 |
| 6.  | 2 | 476  | 325 | 16 |
| 7.  | 2 | 968  | 80  | 16 |
| 8.  | 1 | 968  | 70  | 16 |
| 9.  | 2 | 873  | 500 | 16 |
| 10. | 2 | 994  | 457 | 3  |

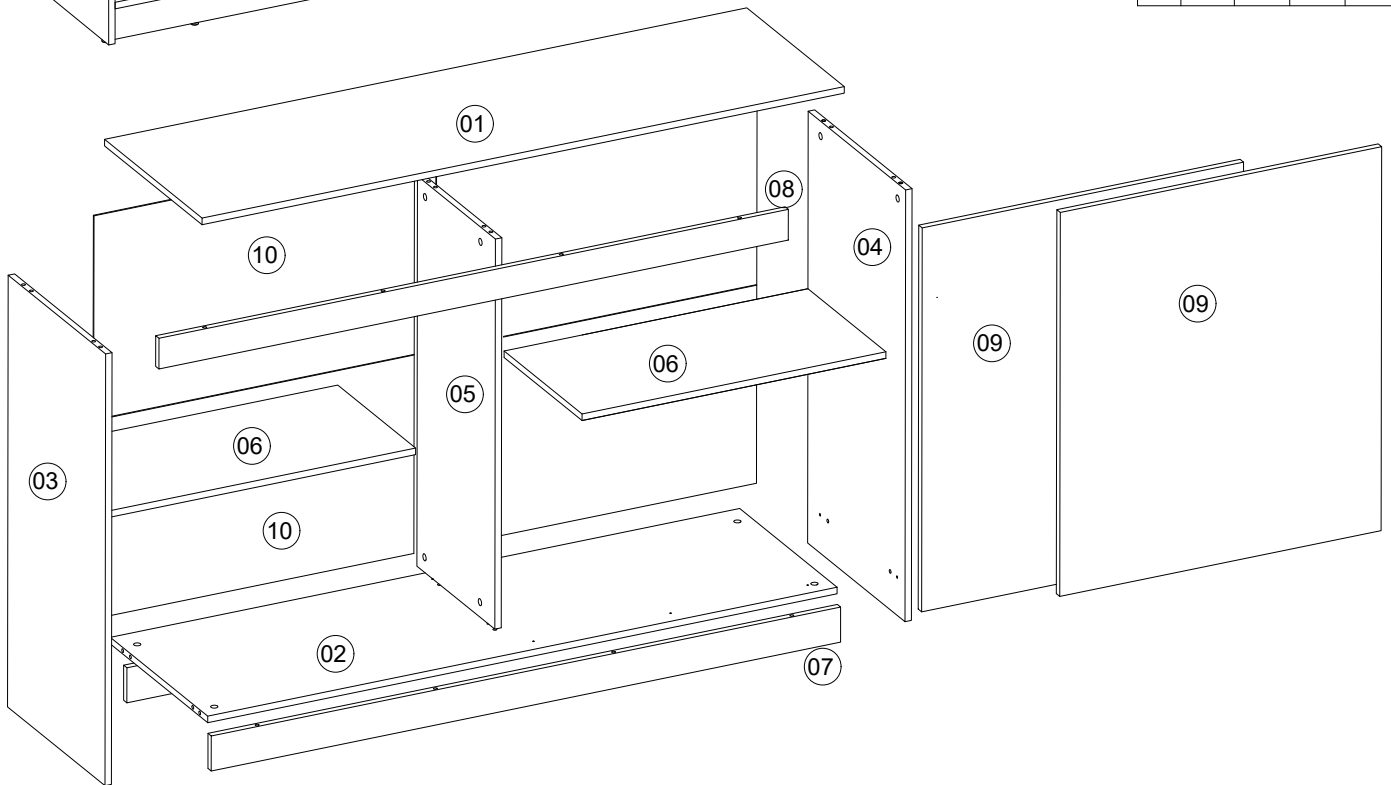

1

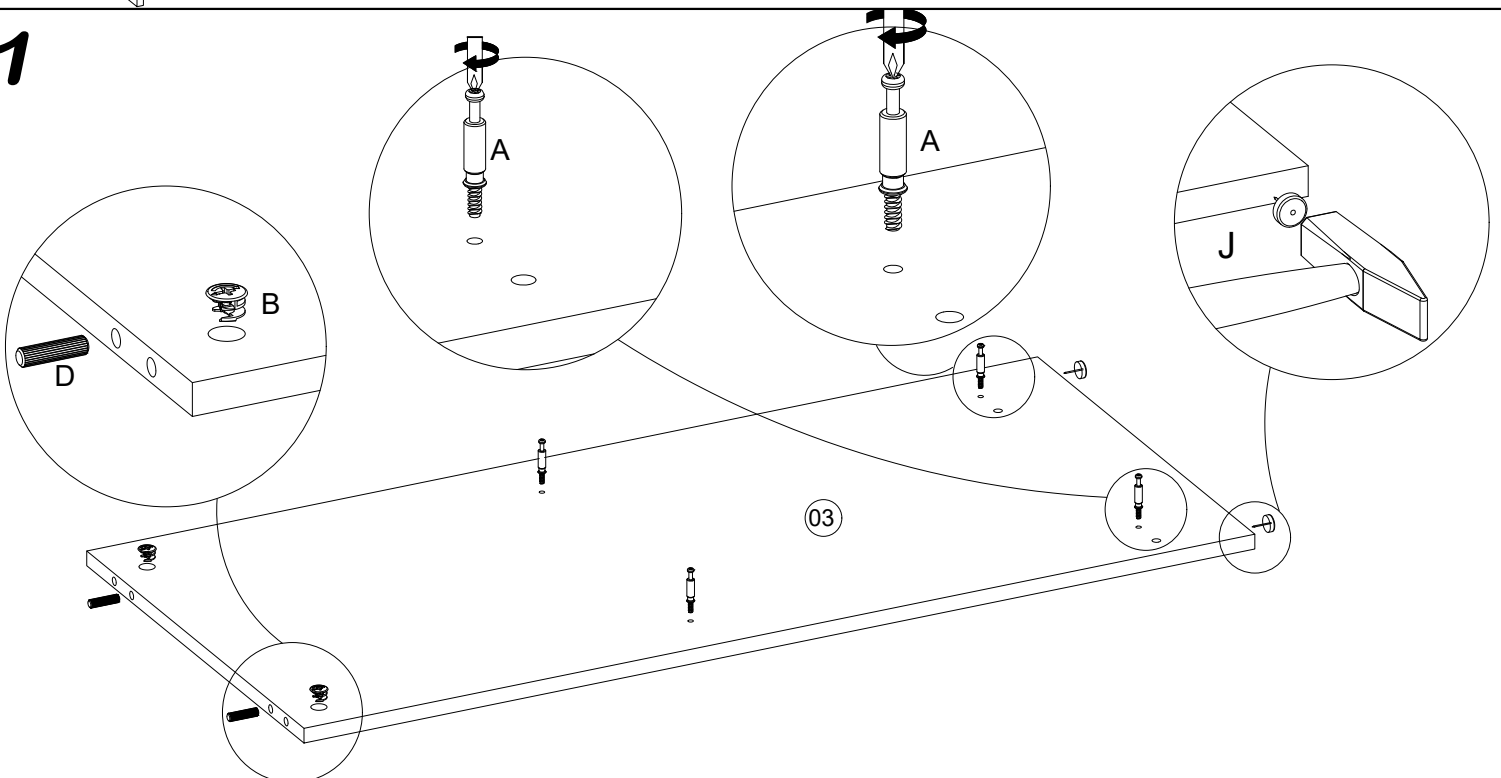

2

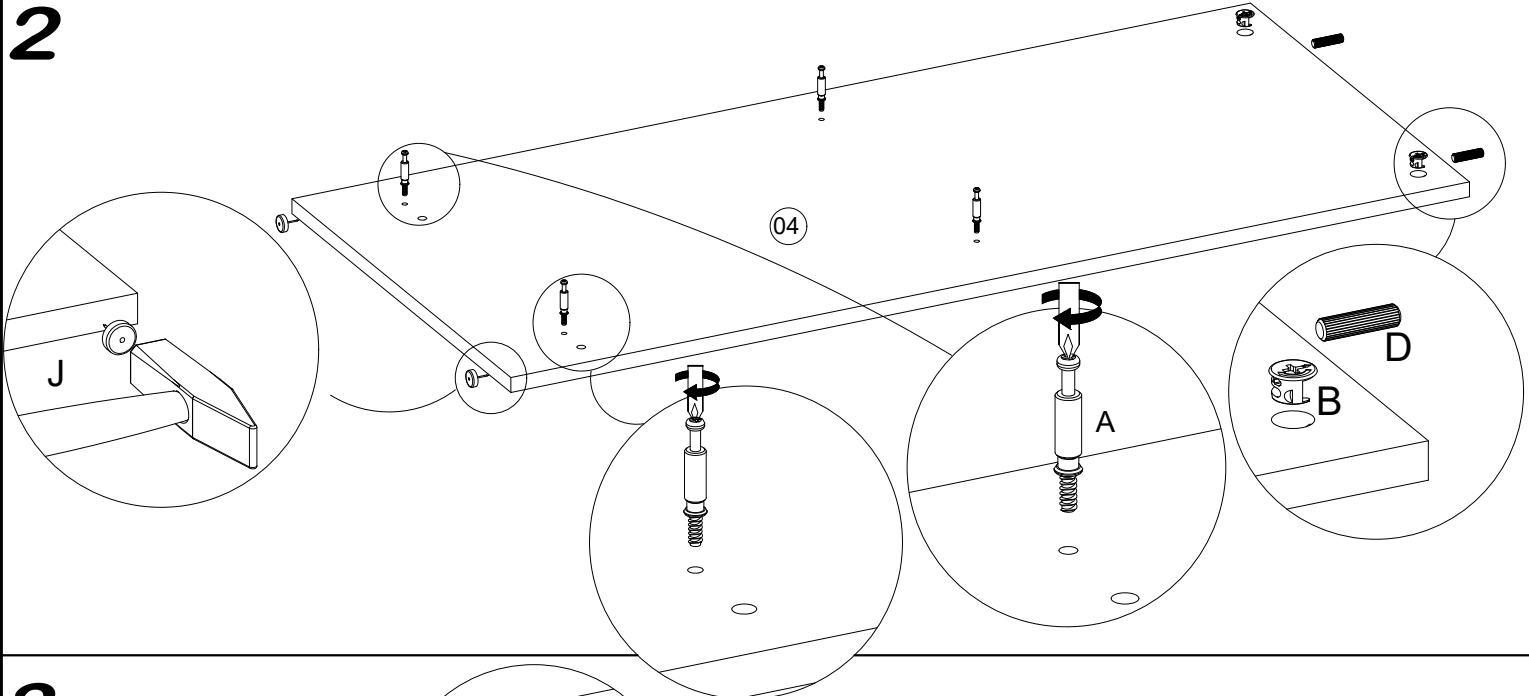

3

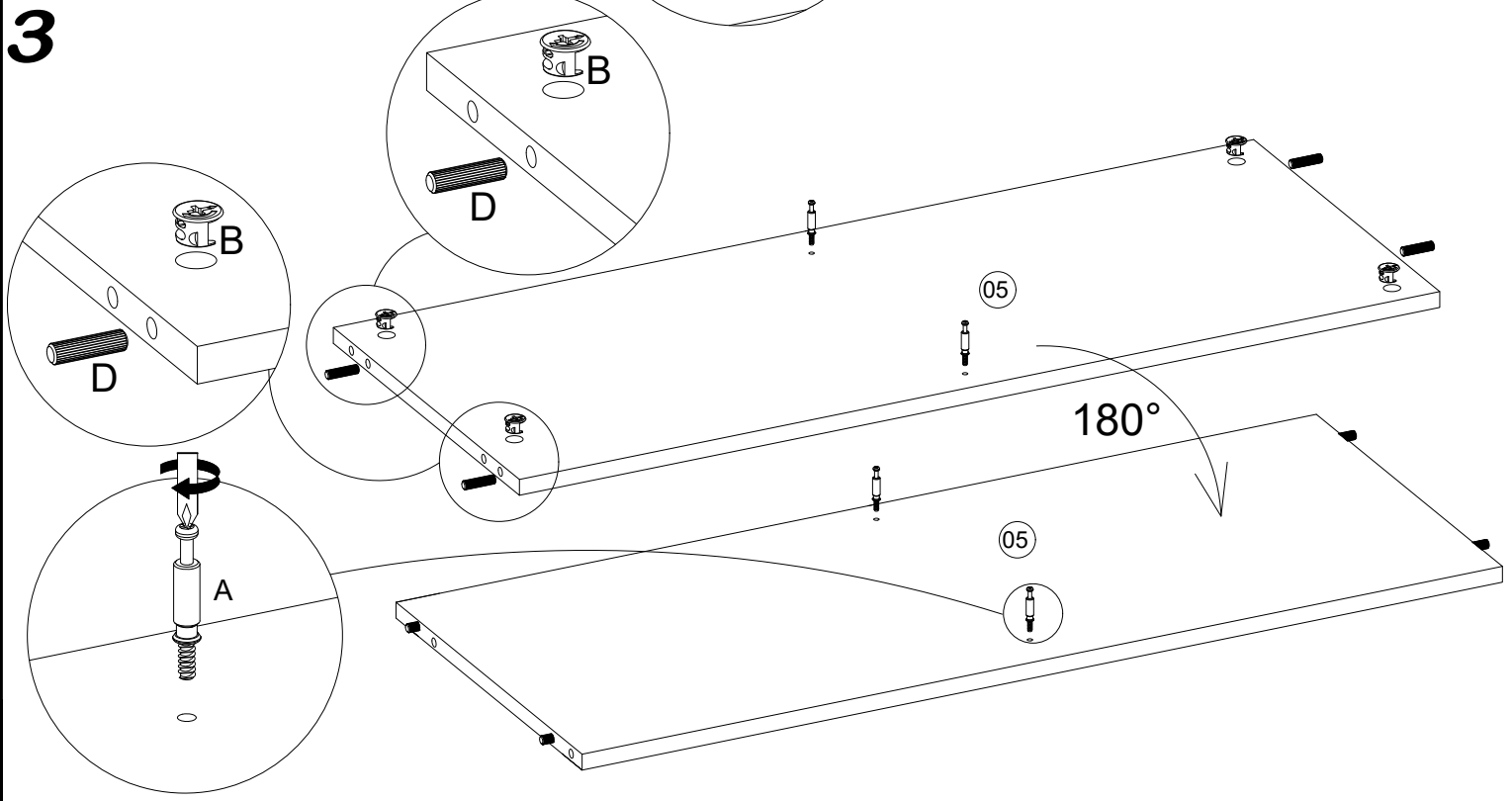

4

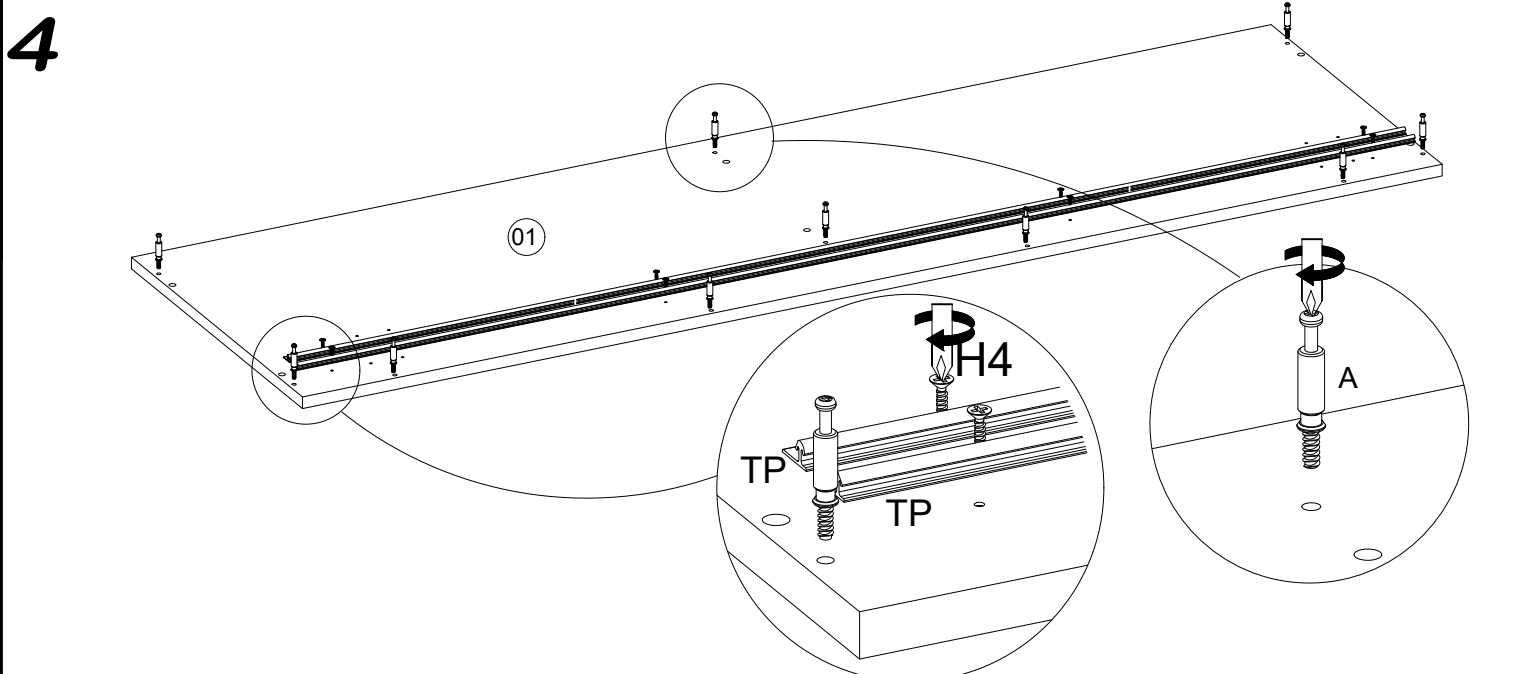

5

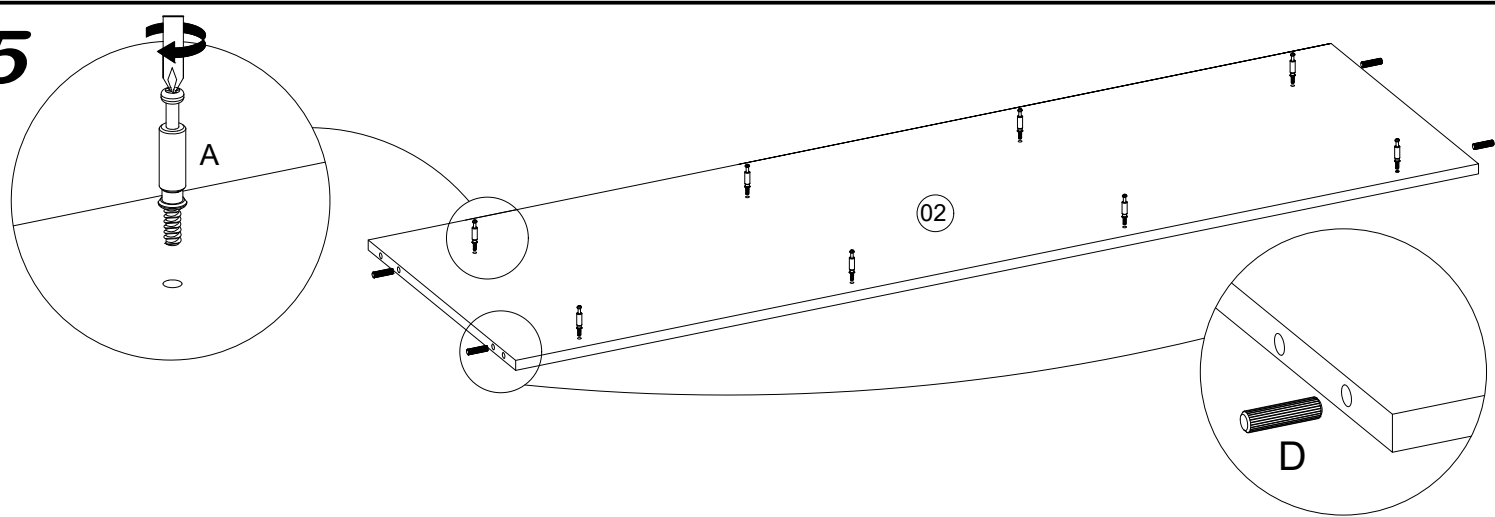

6

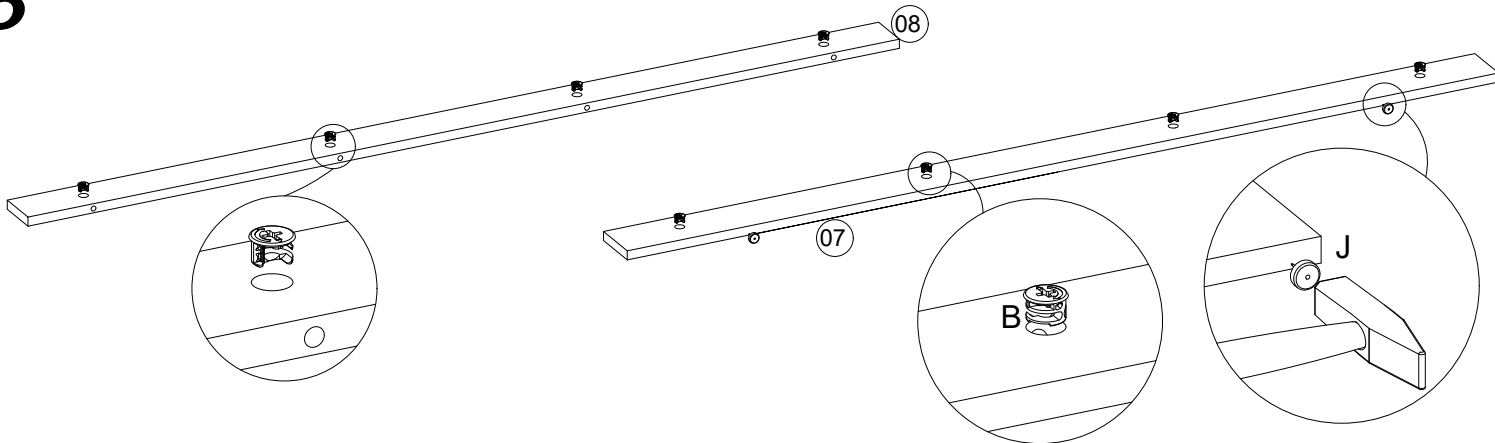

7

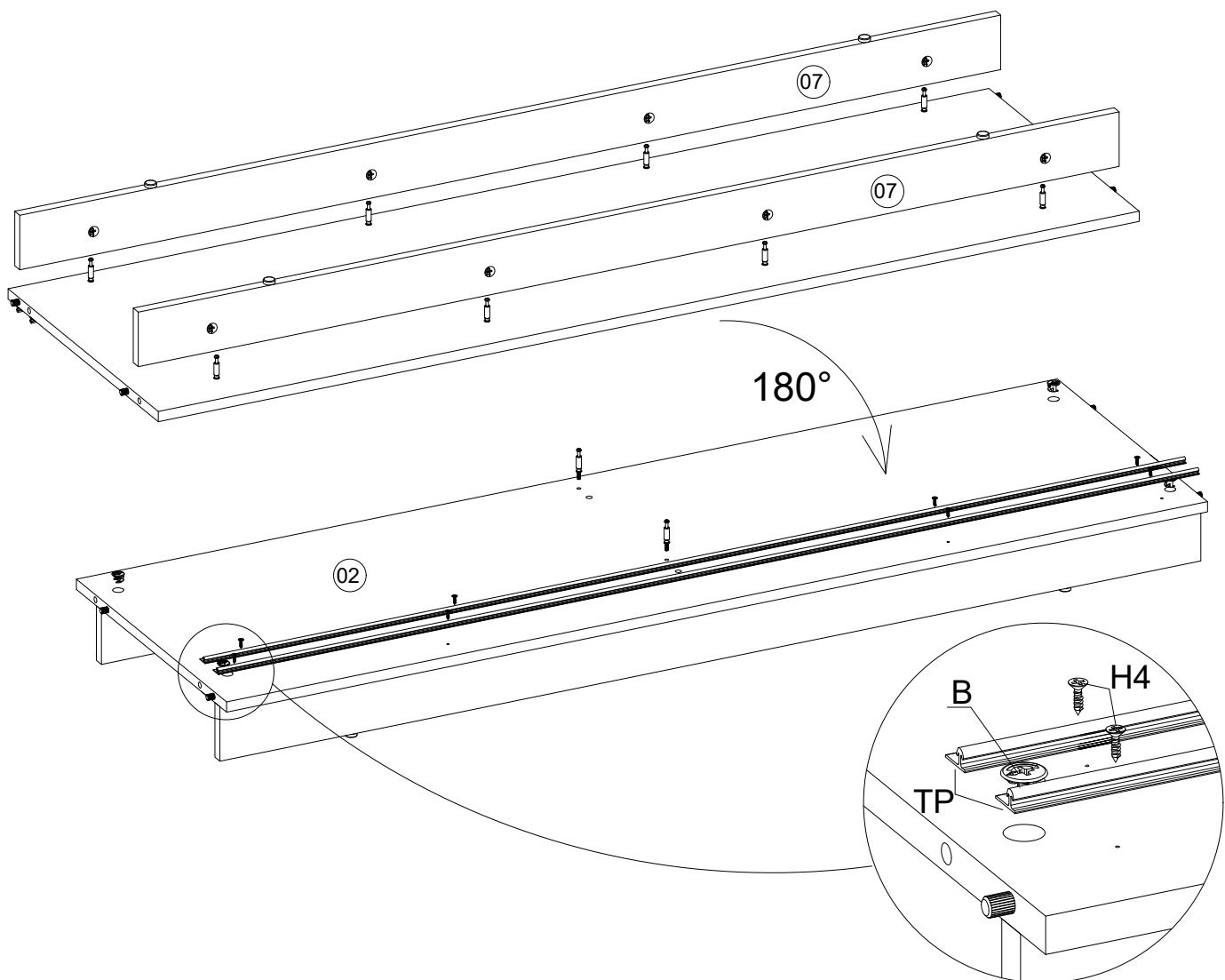

8

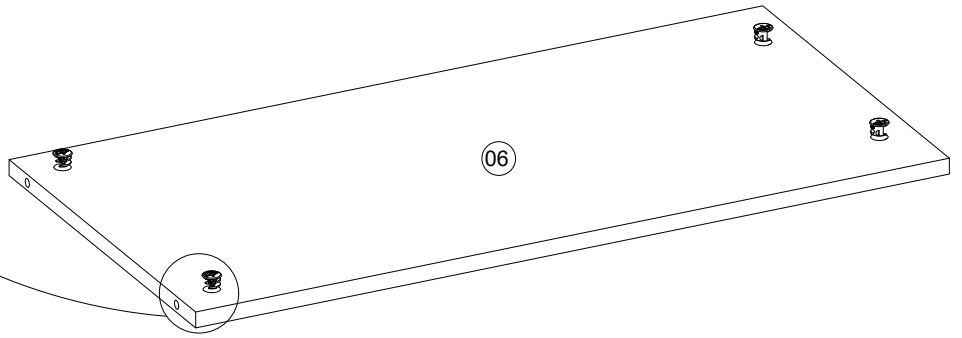
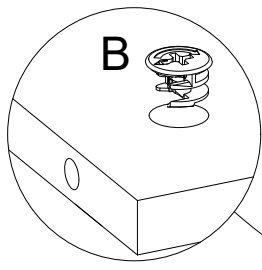

9

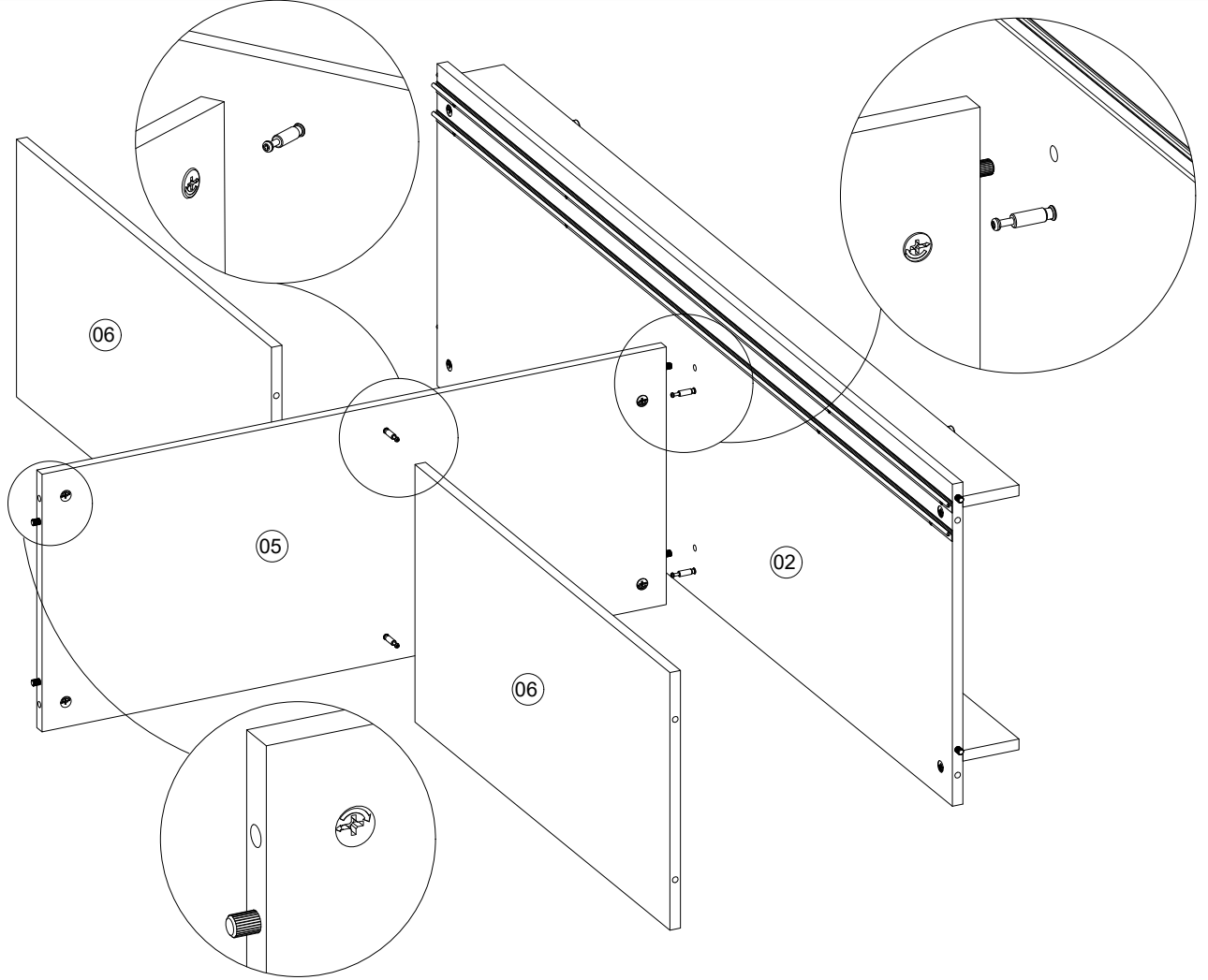

10

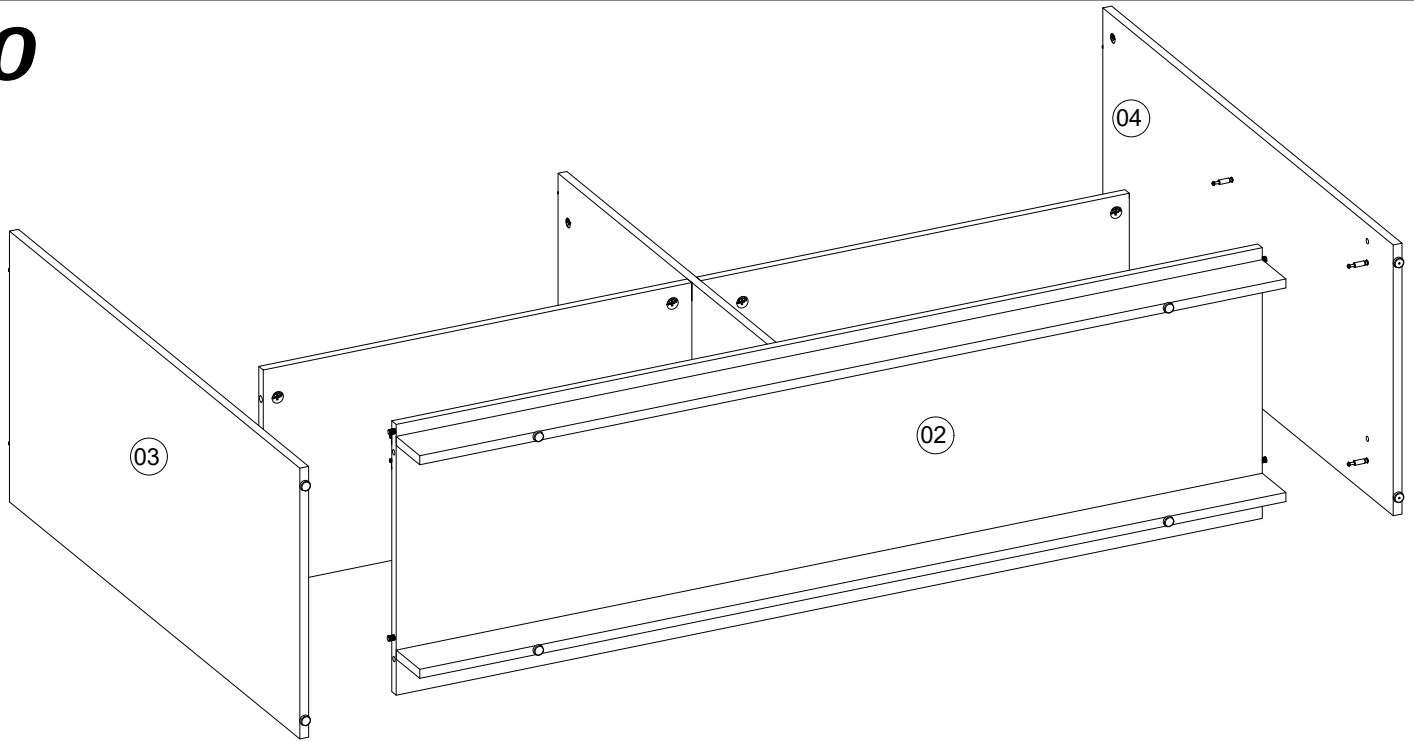

11

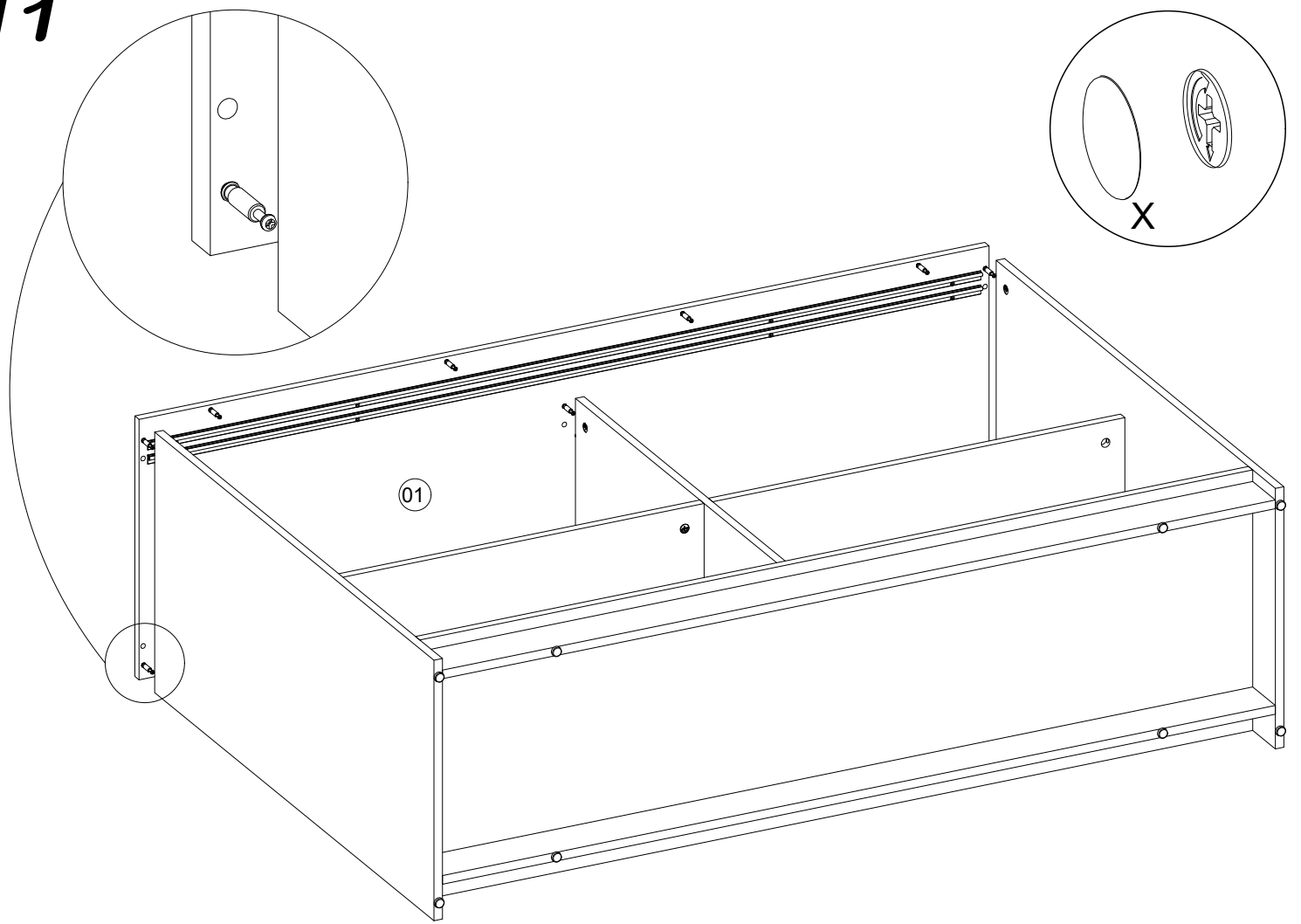

12

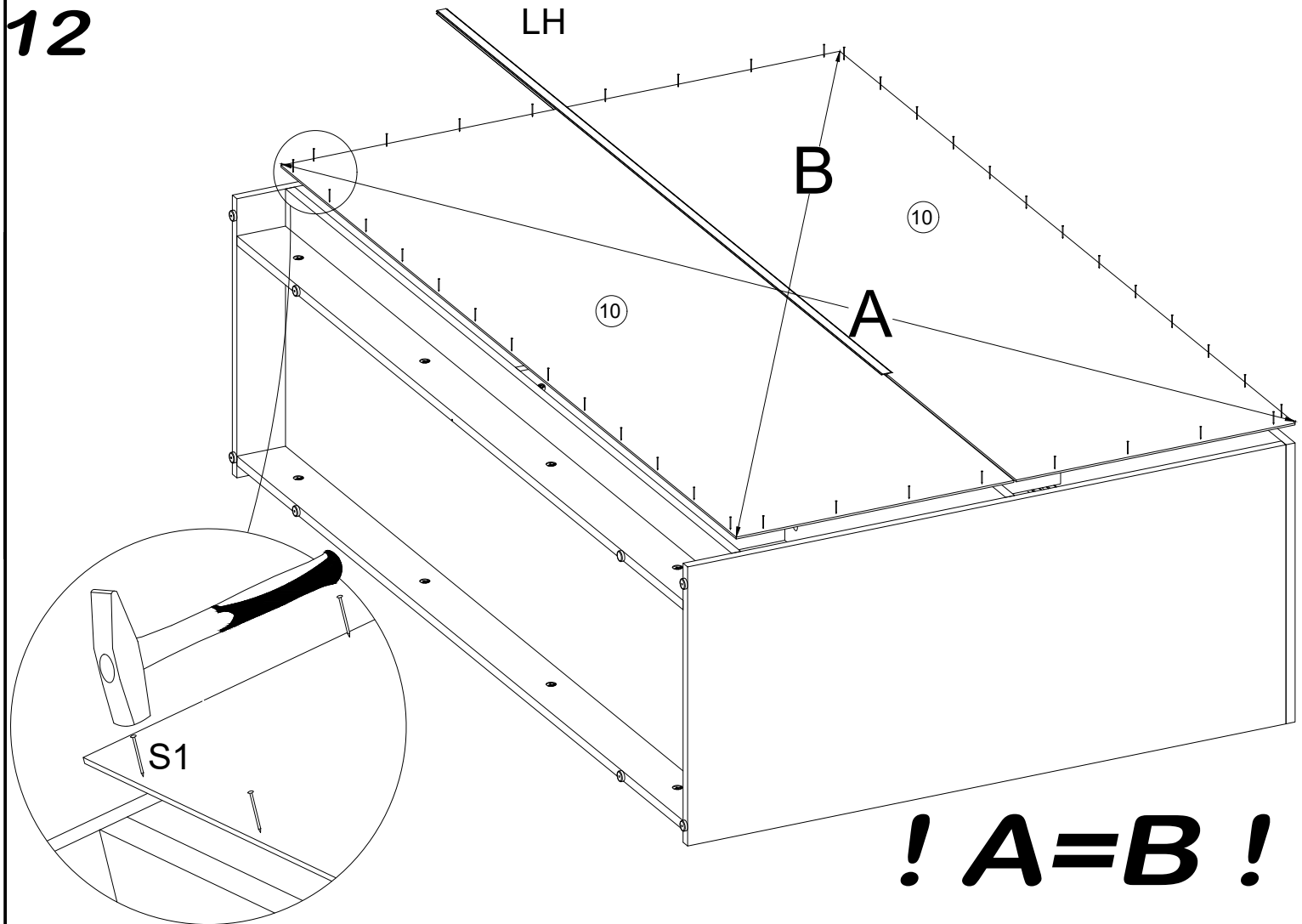

13

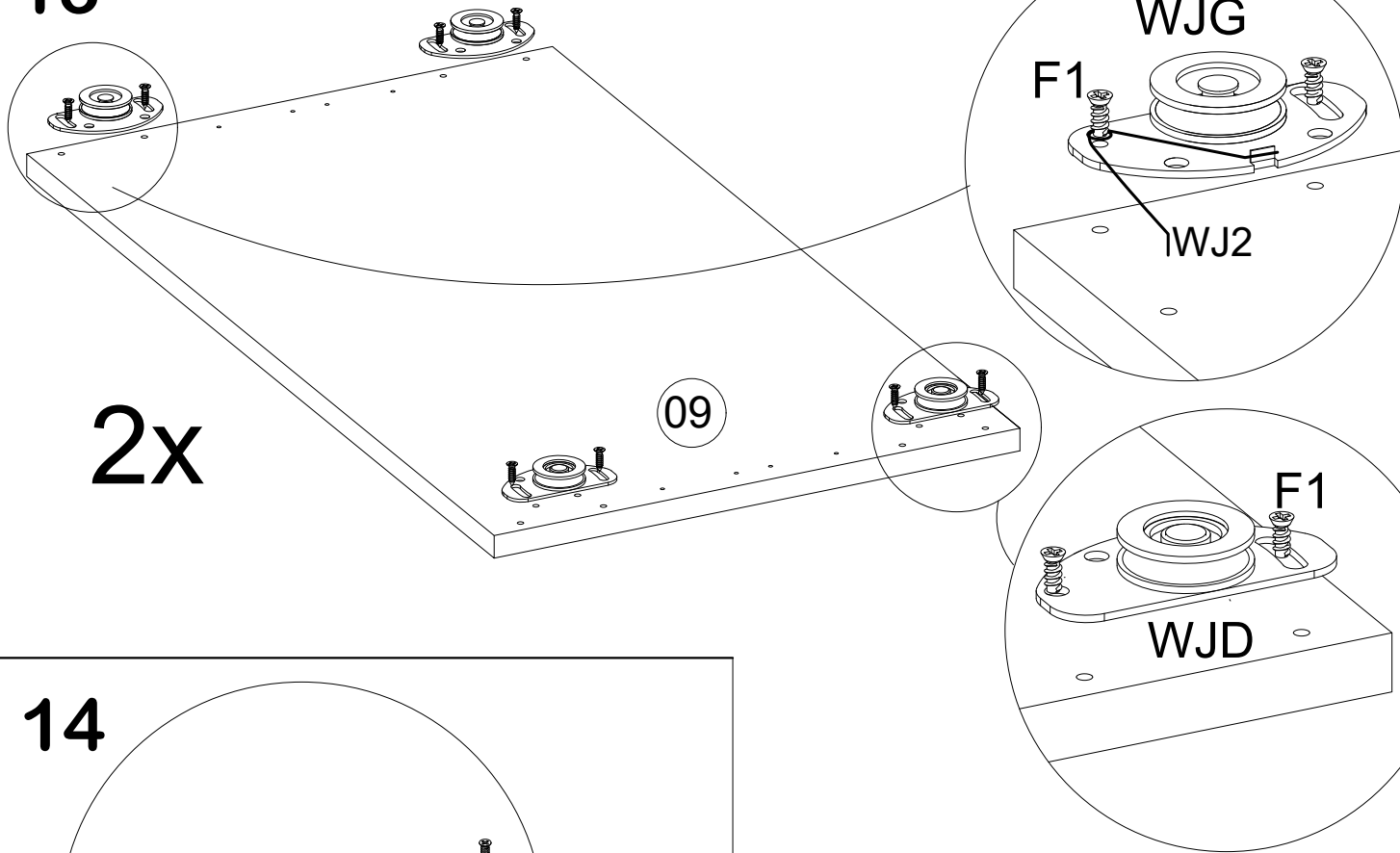

2x

14

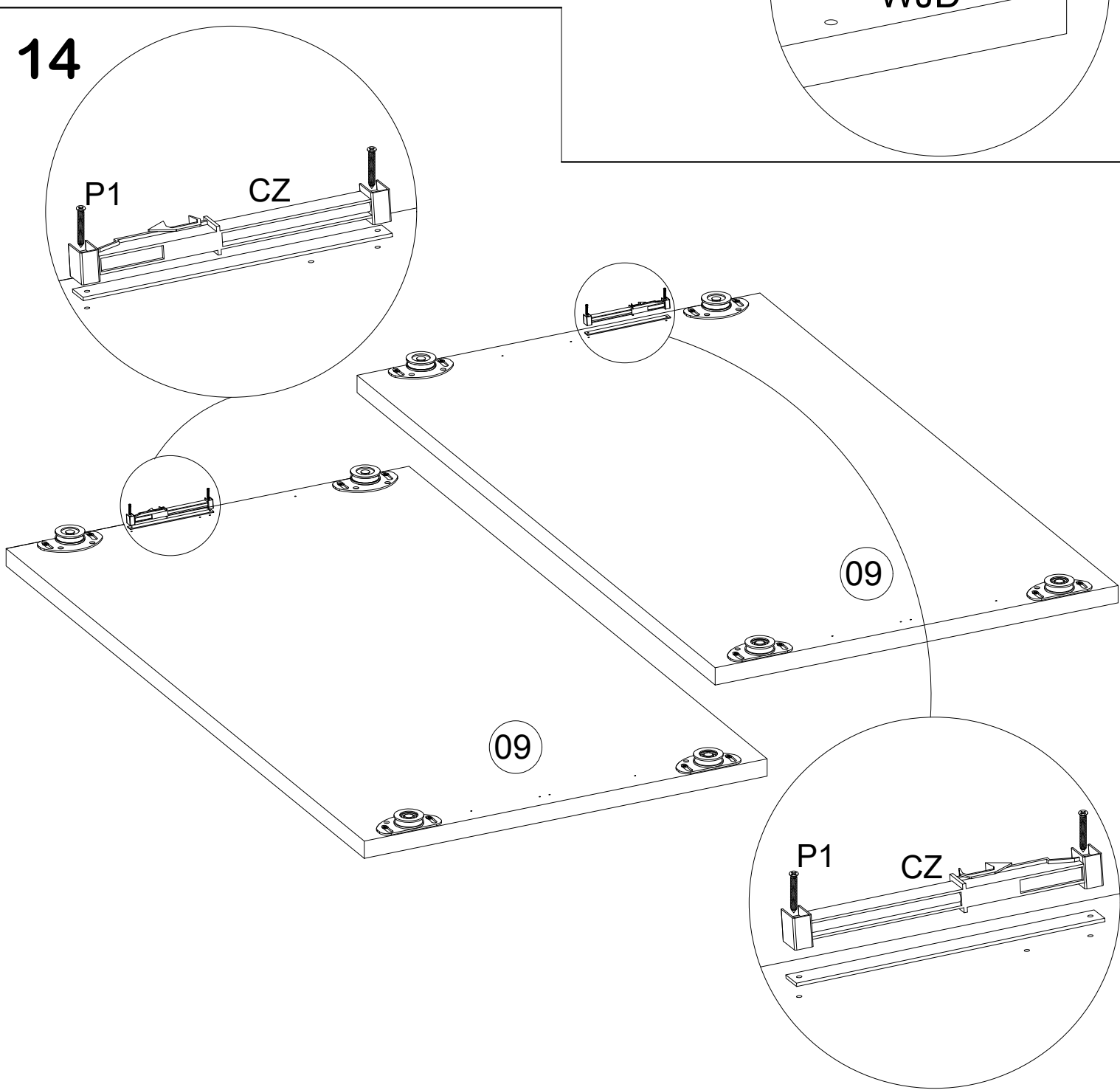

15

**WARIANT 1**

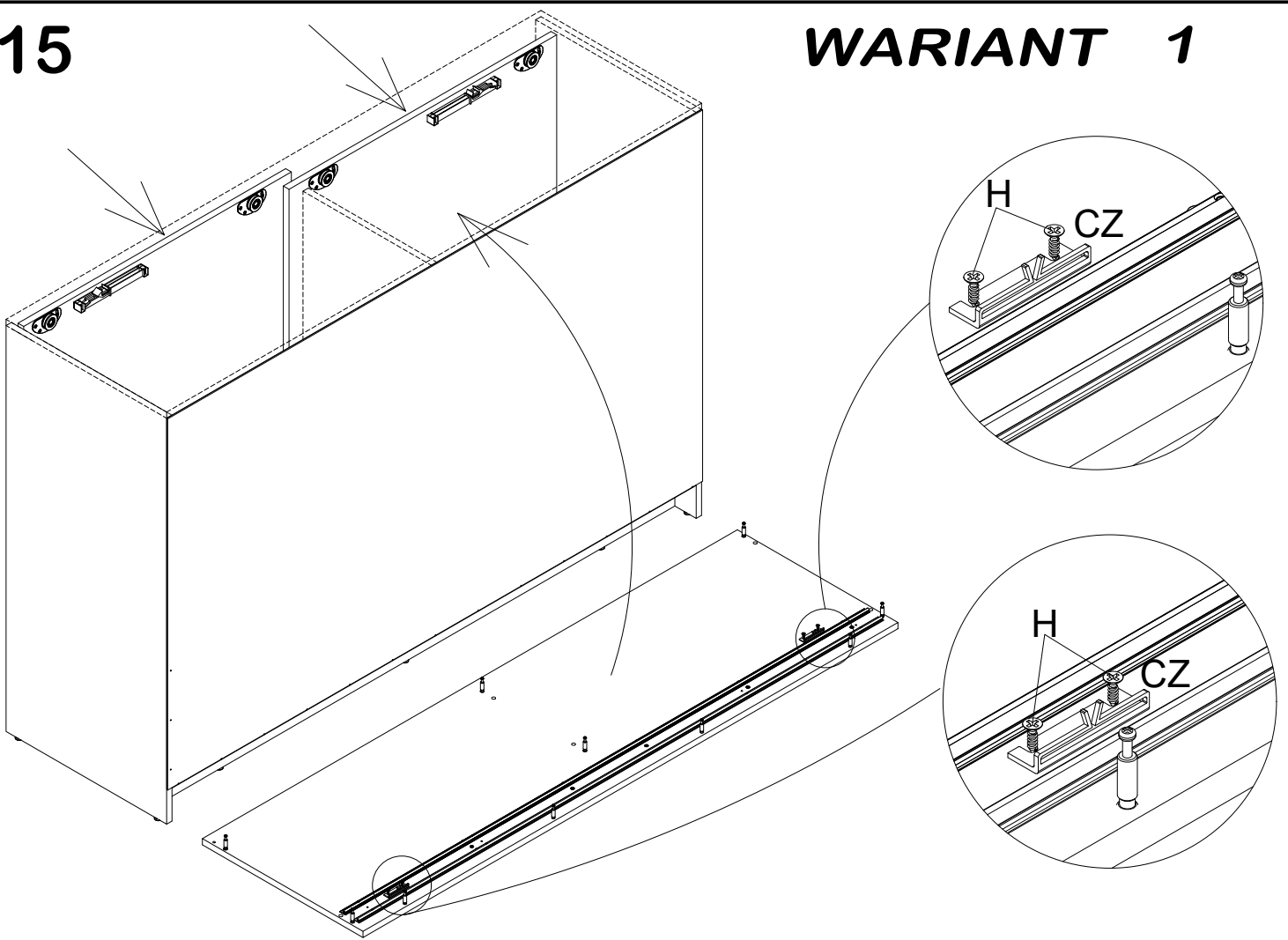

16

**WARIANT 2**

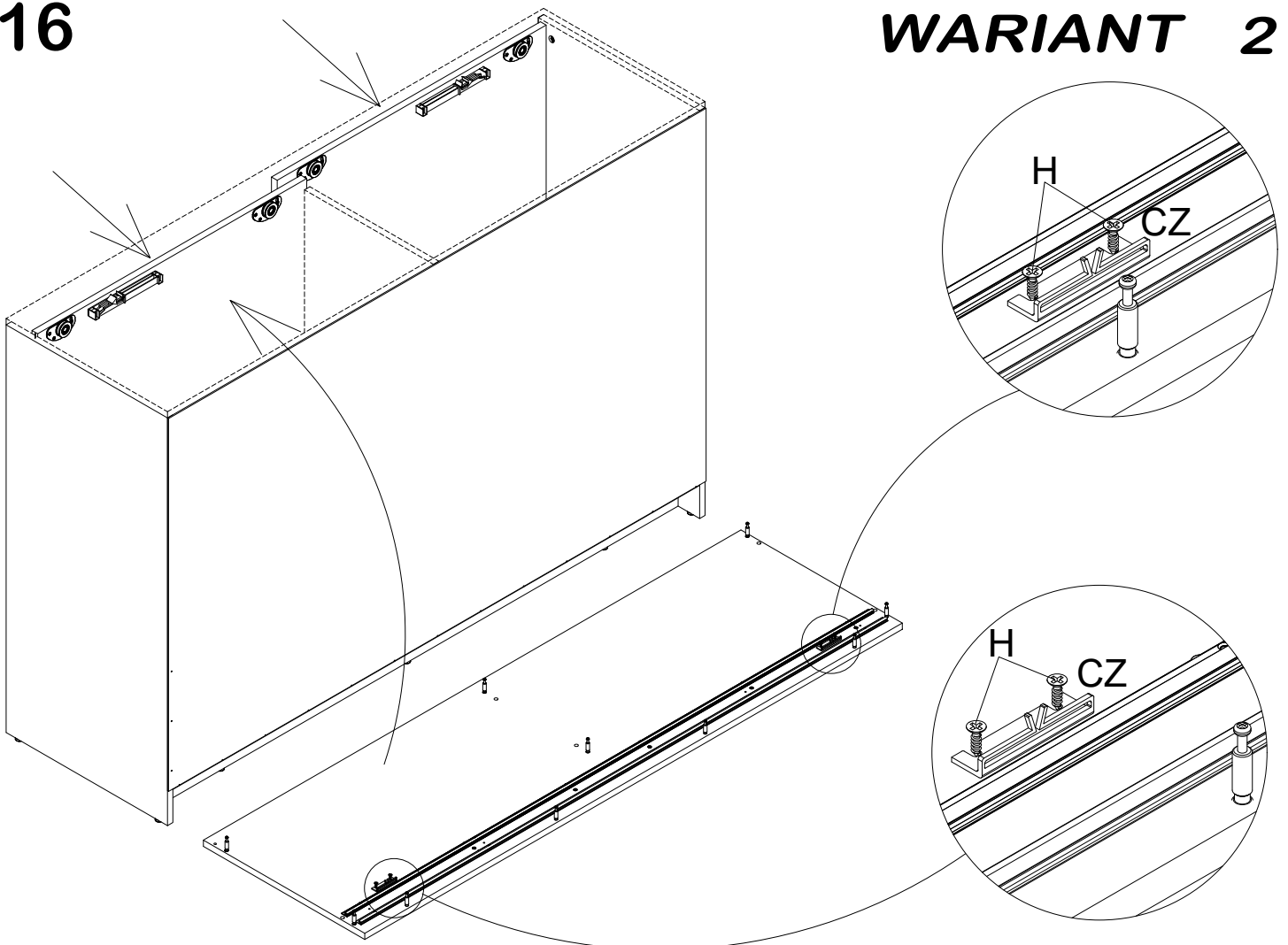



# 17

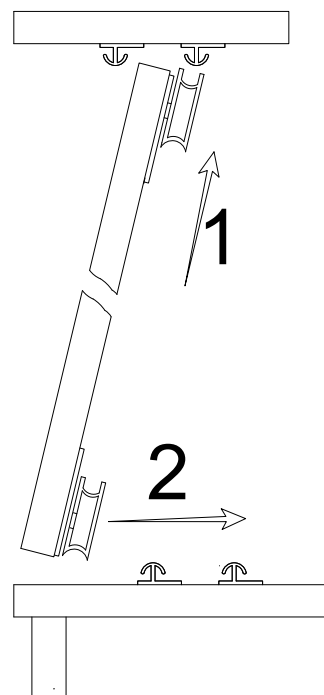
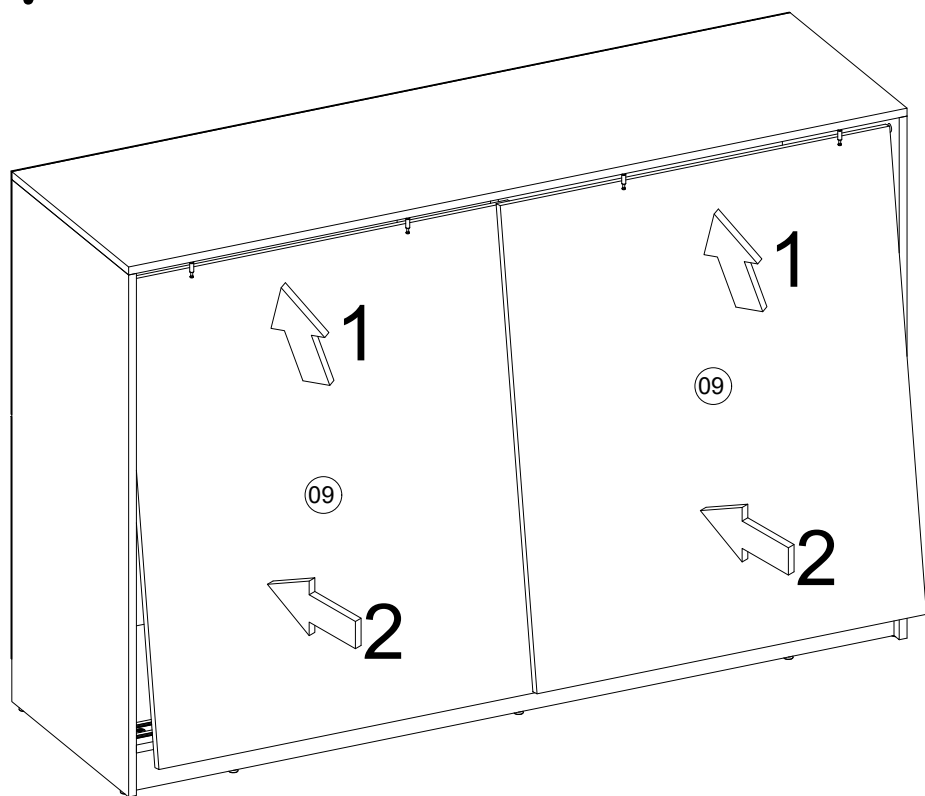

# 18

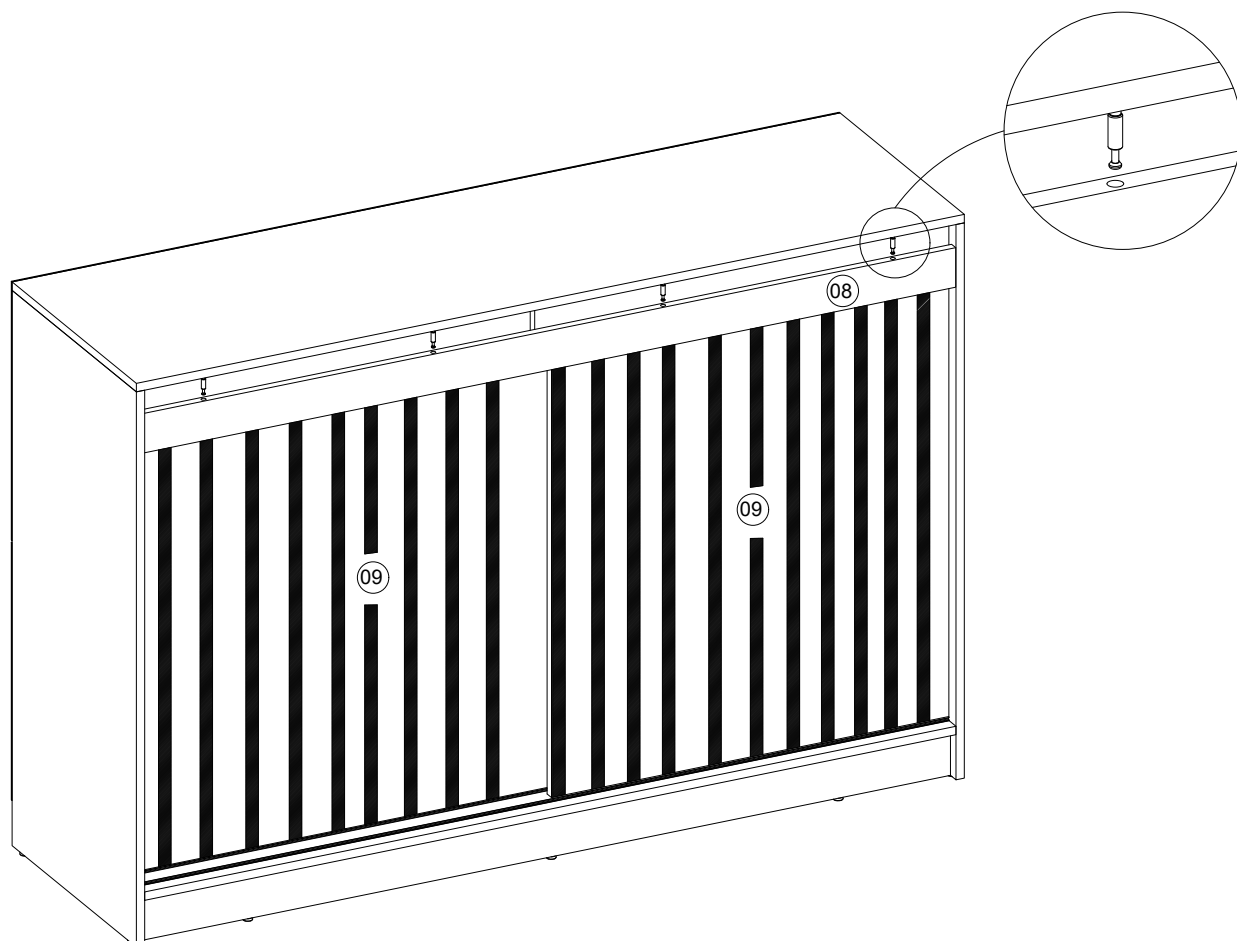

# 19

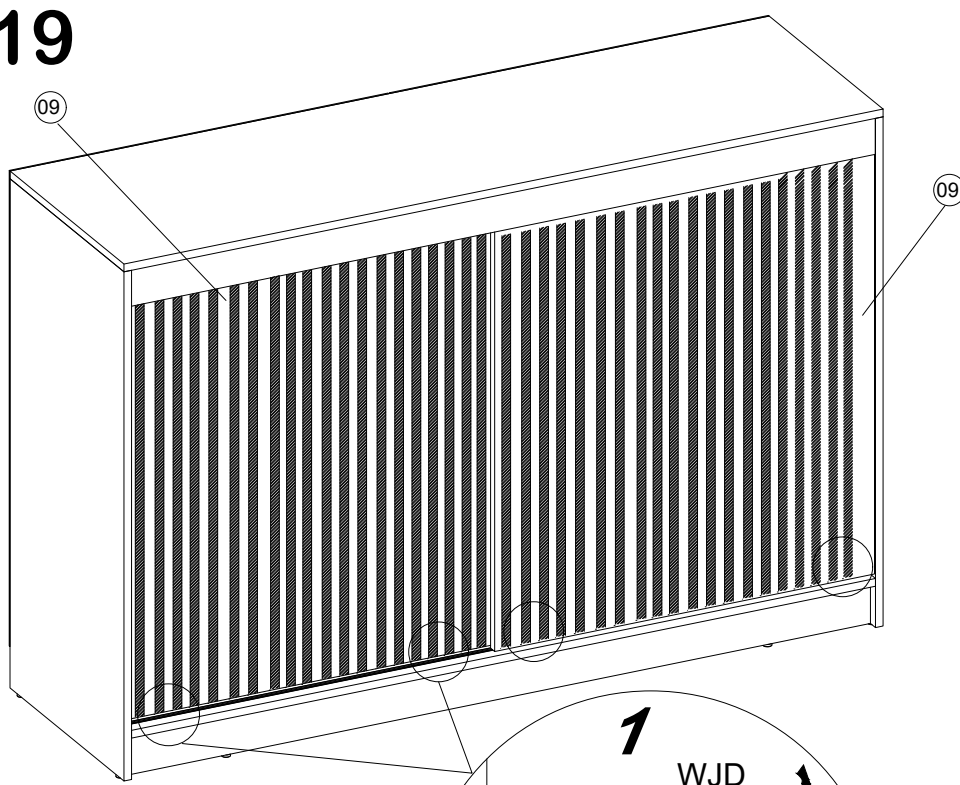

PL> PO WYREGULOWANIU  
DRZWI WKREĆCIĆ WKREŃT NR 3  
D >NACH EINSTELLUNG DER TÜR  
SCHRAUBE NR. 3 EINSETZEN

GB>AFTER ADJUSTING THE  
DOOR, USE SCREW NO 3

NL>NA HET AFSTELLEN VAN DE DEUR,  
PLAATS SCHROEF NO.3

F >APRÈS LE RÉGLAGE DE LA PORTE,  
INSÉRER LA VIS N°3

CZ> PO SEŘÍZENÍ DVEŘÍ  
ŠROBUJEME ŠROUB Č.3

SK> PO NASTAVENÍ DVEŘÍ  
ZASKRUTUJTE SKRUTKU Č.3

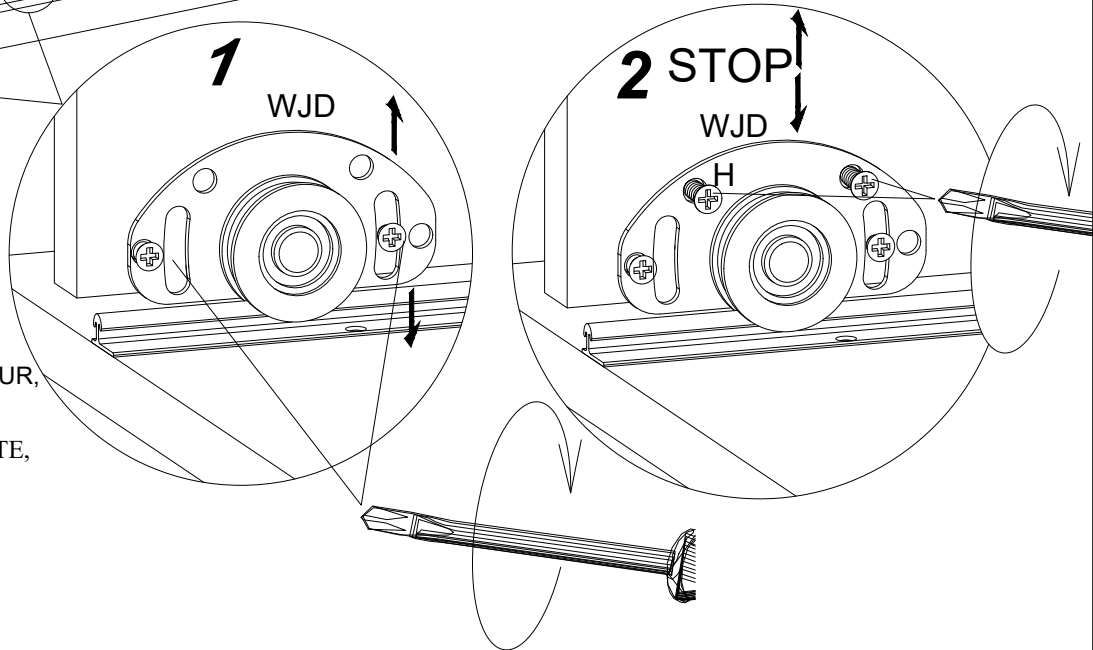

# 20

