

# FLY 28 -- FY 42-C

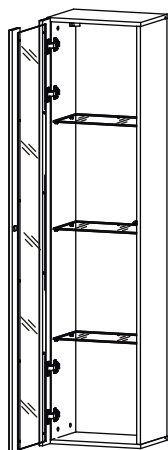

NO	Dim.		Col.-No	Qty
1	1668	274	1	1
2	1668	274	1	1
3	400	274	1	2
4	364	234	1	3
105	1680	378	1	1
6G	394	410	1	1
6D	394	410	1	1
7	925	362	1	1

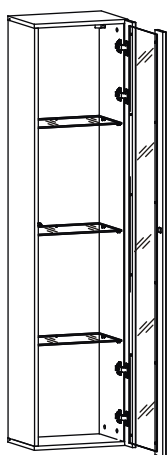
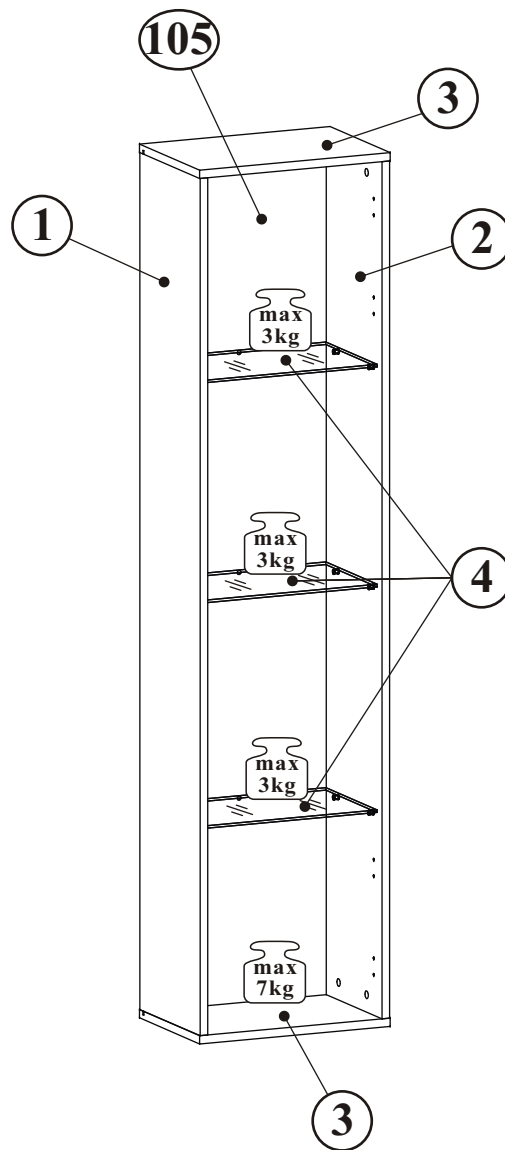
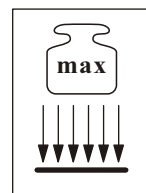
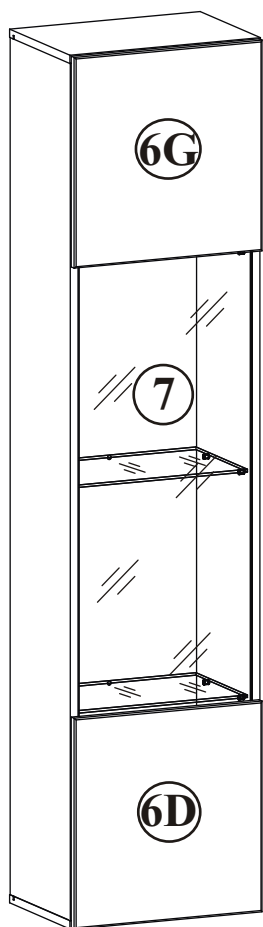
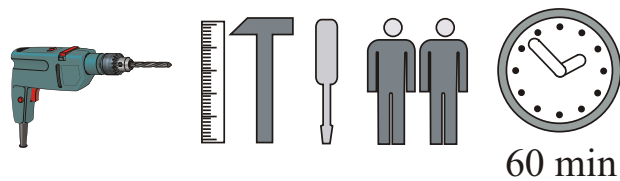

FLY 28--FY 42-C

A1 x8 ø8x36	B4 x8	B5 x8 ø15x12	G5 x8	ZR1 x2	D6 x4 USØ3,5x30
E2 x4 H=0	E1 x4 Ø26 H=0	D10 x10 USØ3,5x13	AM x1	G20 x12	Z2 x8 Ø5
P2 x6	UP13 x6 UPØ3x16	S1 x12	KR2 x2	G2 x1	

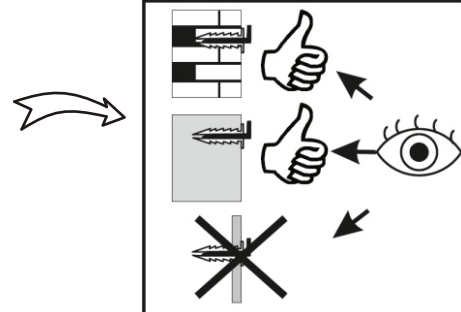
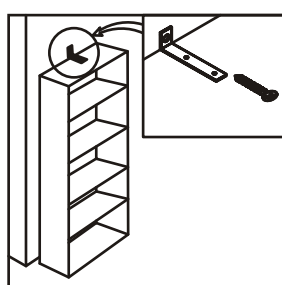
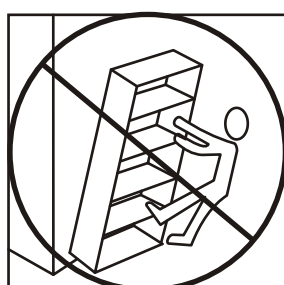
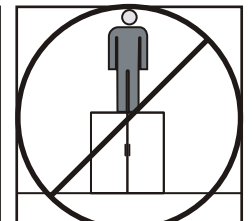
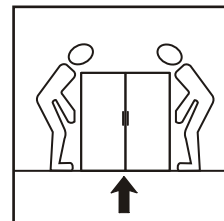
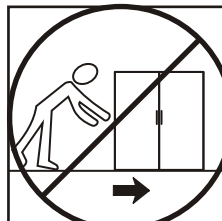
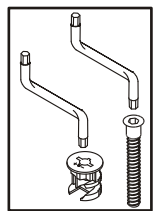
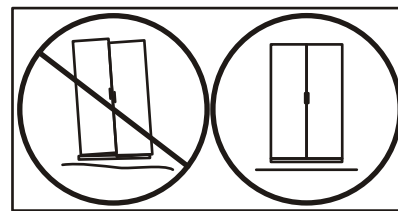
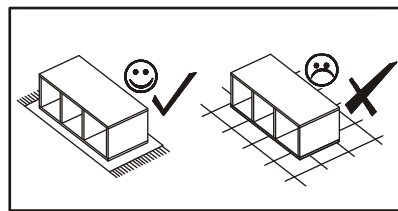
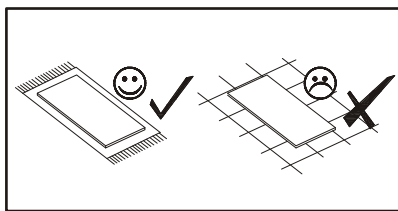
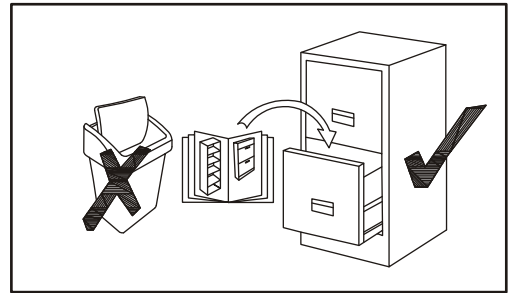
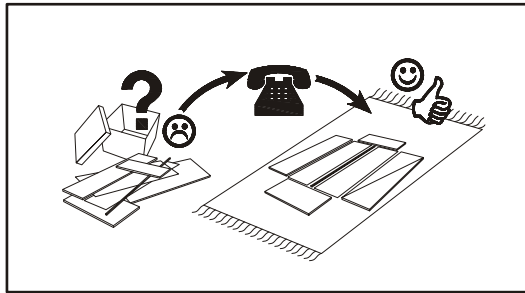
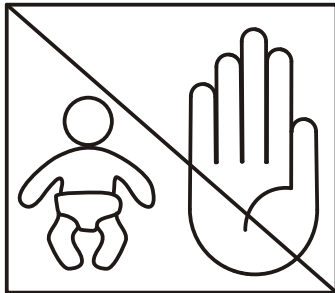
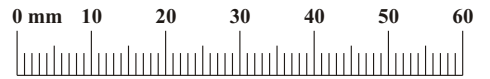

FLY 28--FY 42-C

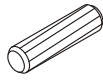
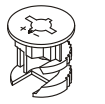
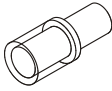
A1		B5		G20	
x8	ø8x36	x8	ø15x12	x12	

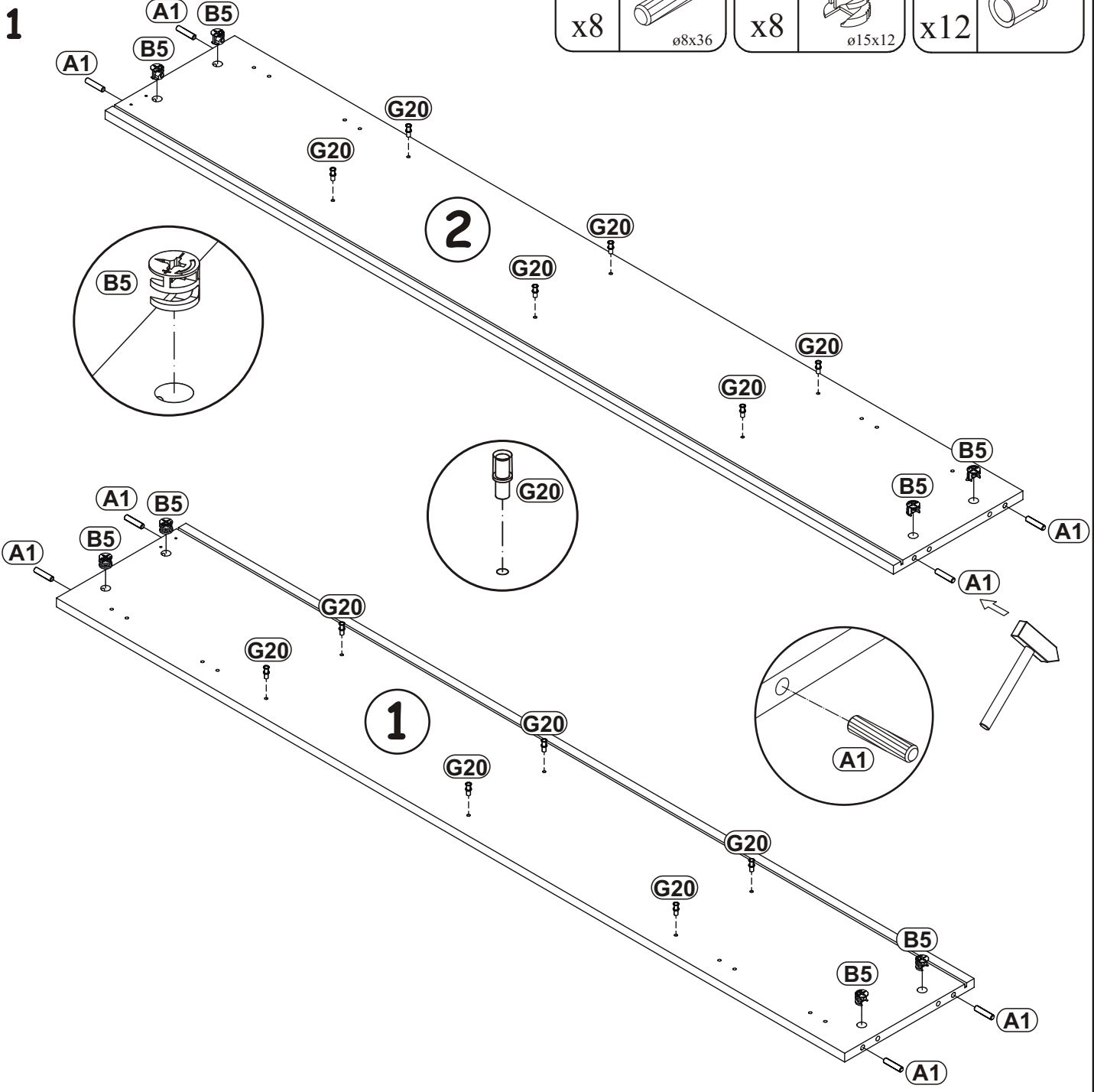

**2**

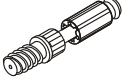
B4	
x8	

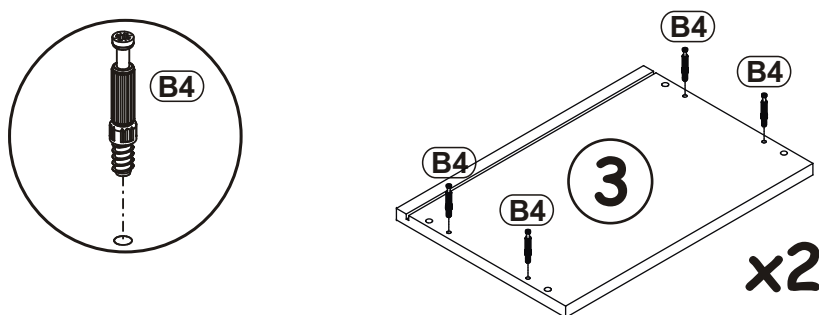

FLY 28--FY 42-C

3

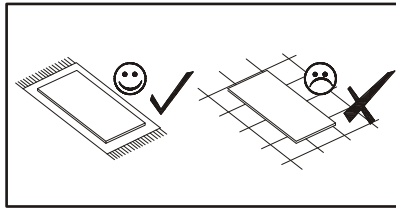

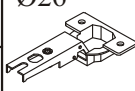
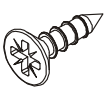
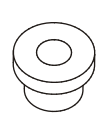
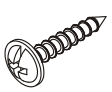

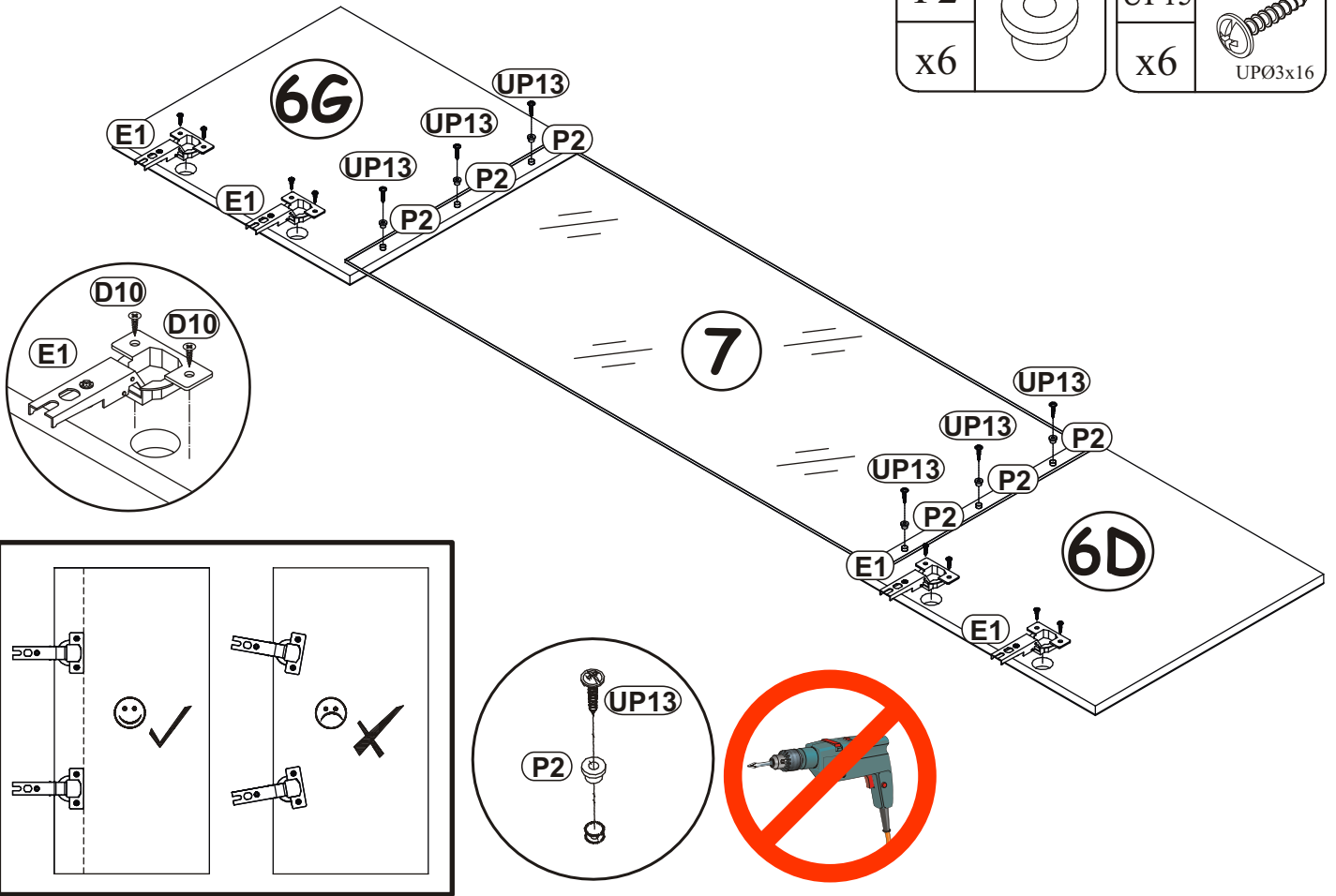
E1	Ø26	D10	
x4	 H=0	x8	 USØ3,5x13
P2		UP13	
x6		x6	 UPØ3x16

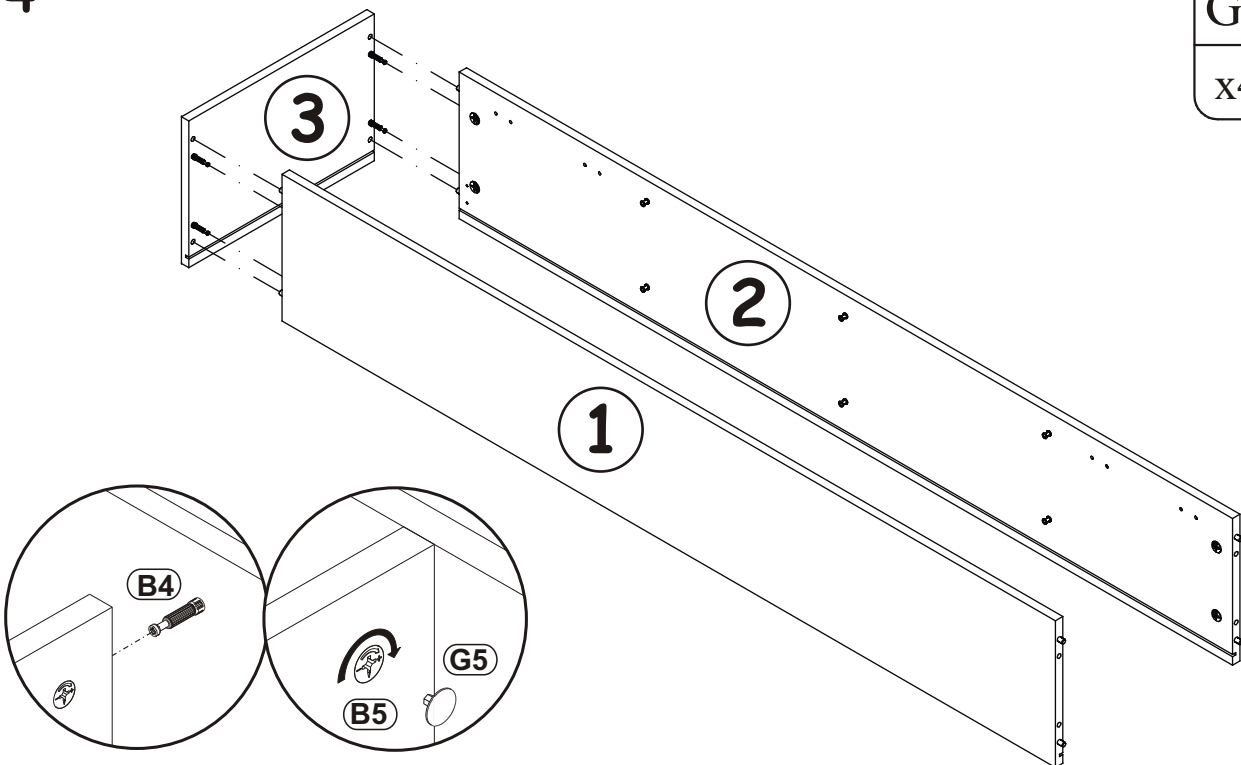

4

G5	
x4	



G5	
x4	

5

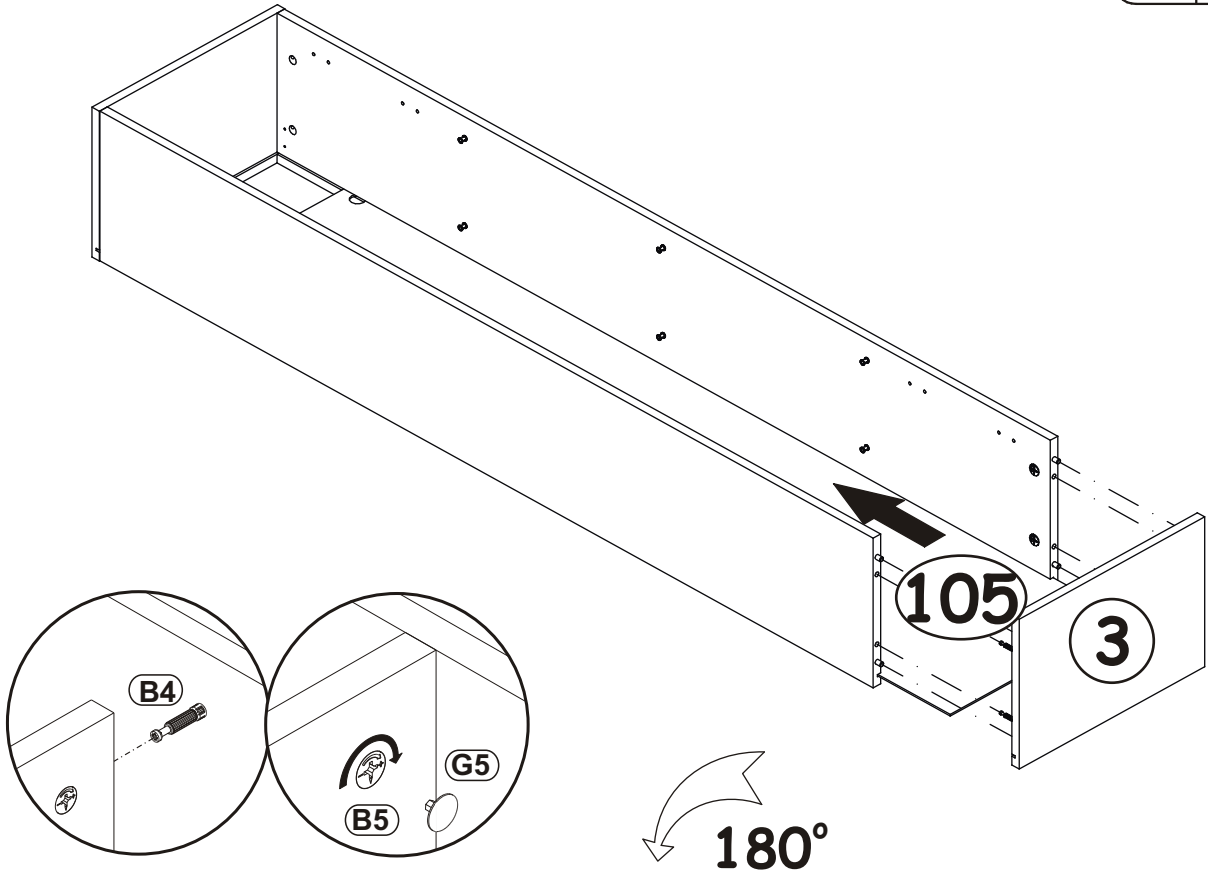

6

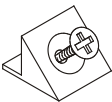

S1	
x12	

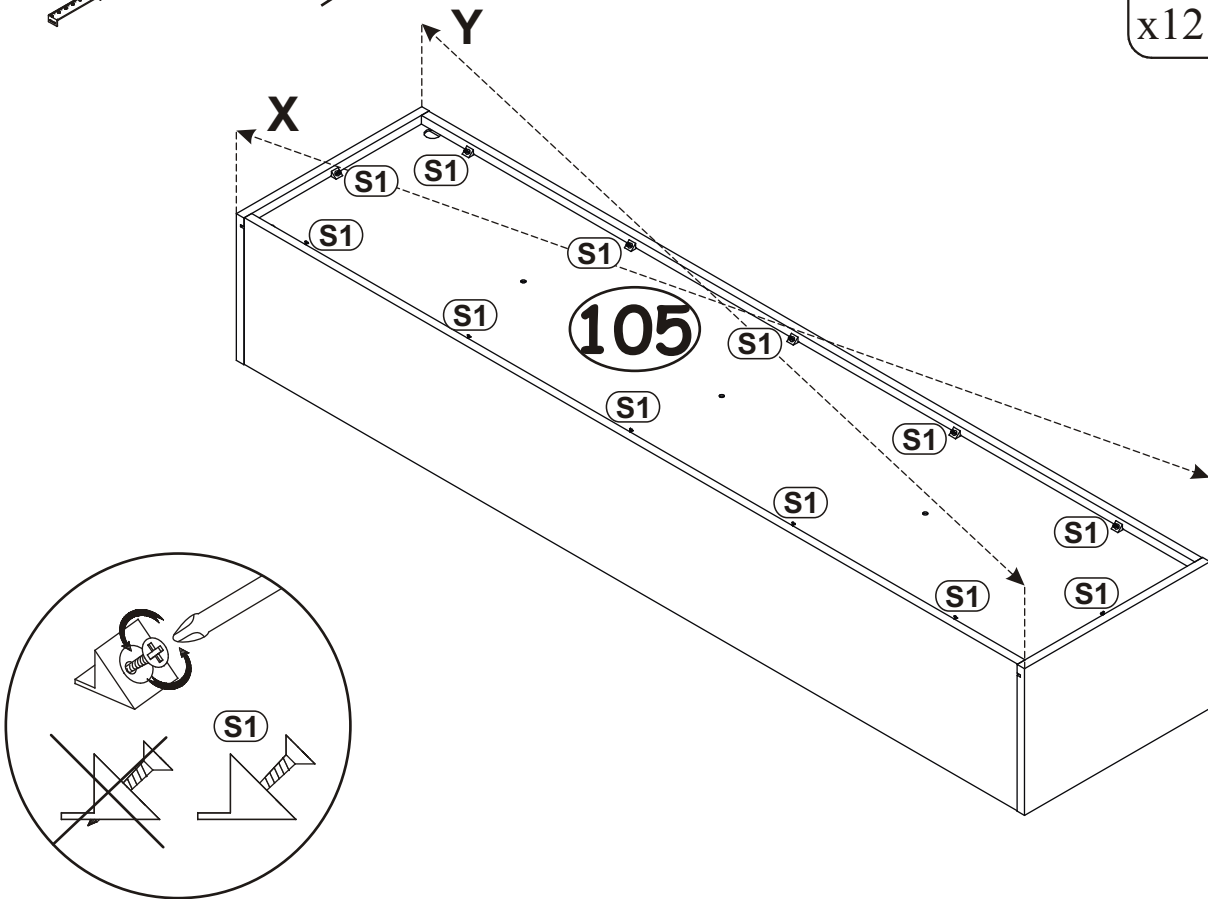

FLY 28--FY 42-C

7

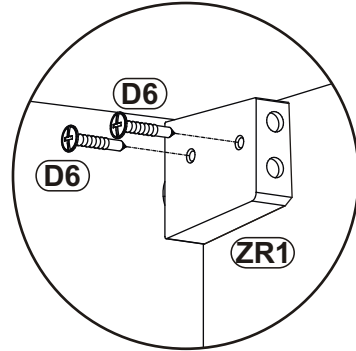
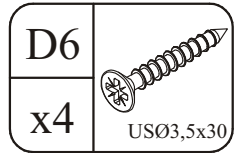
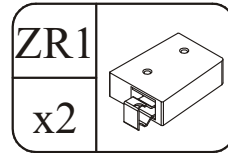
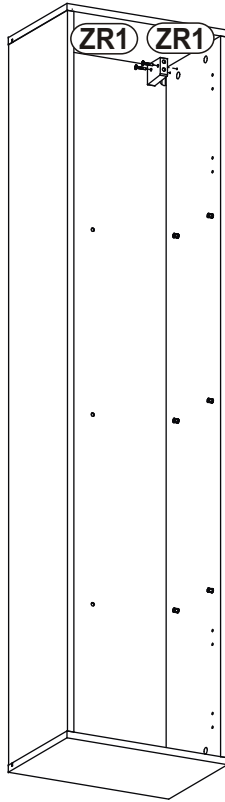
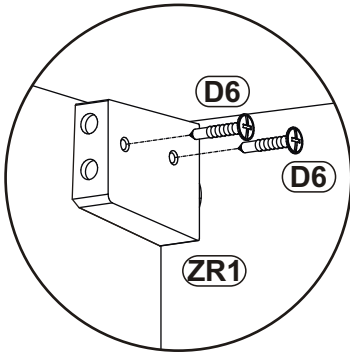

8

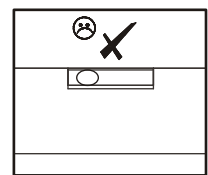
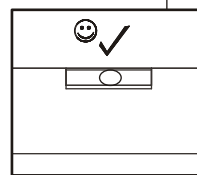
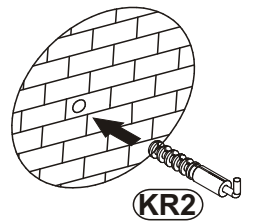
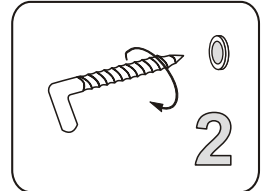
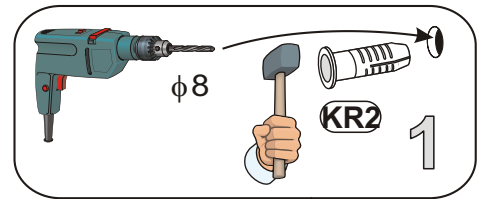
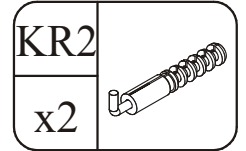
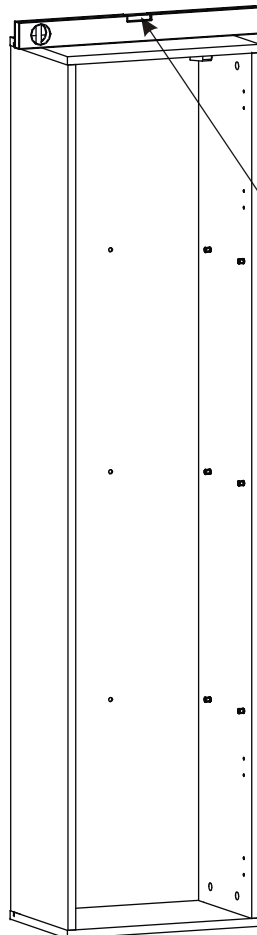
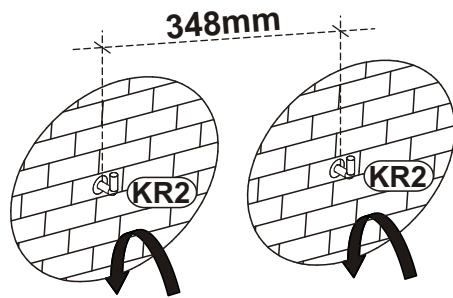
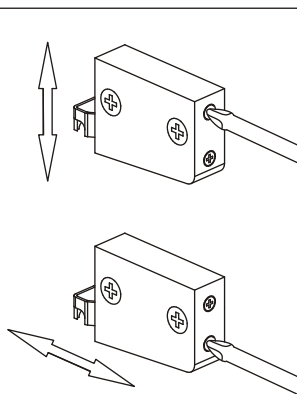
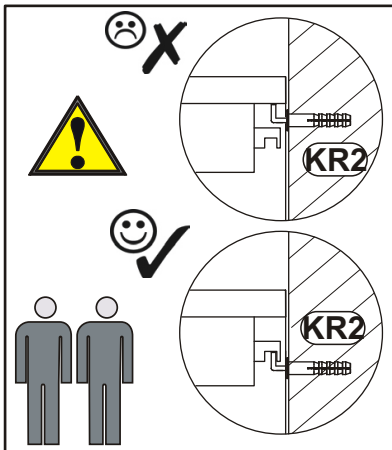
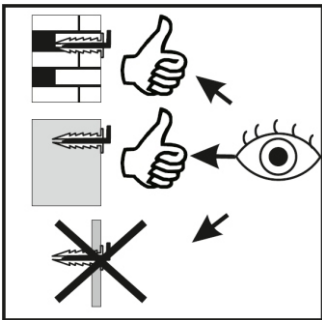

**9-10**

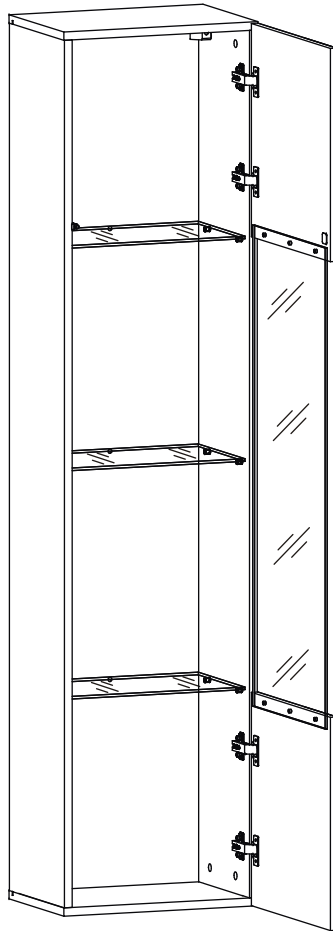

**11-12**

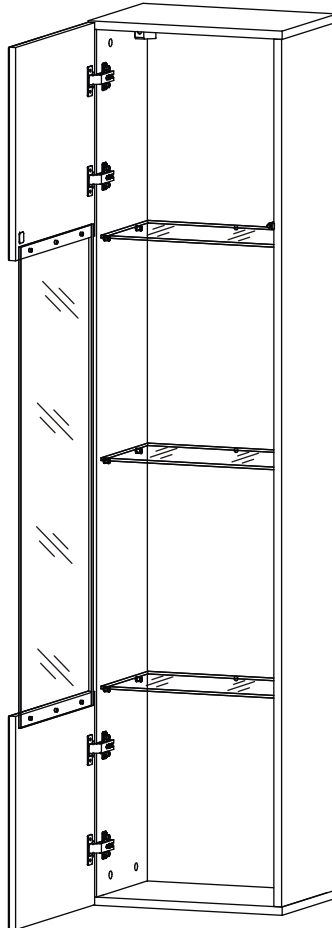

9

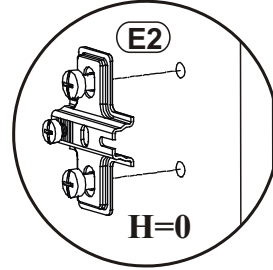
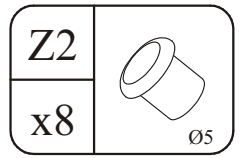
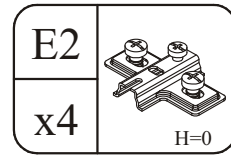
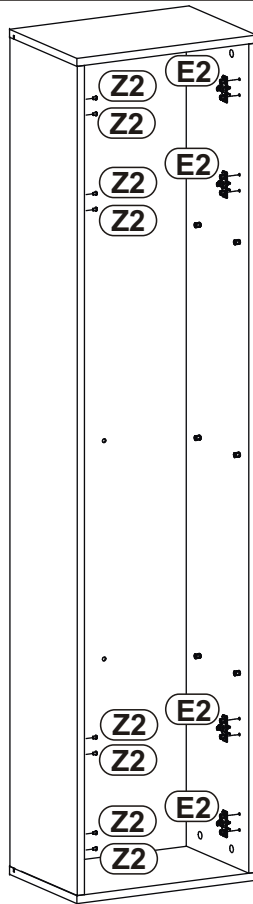
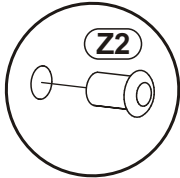
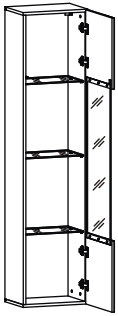

10

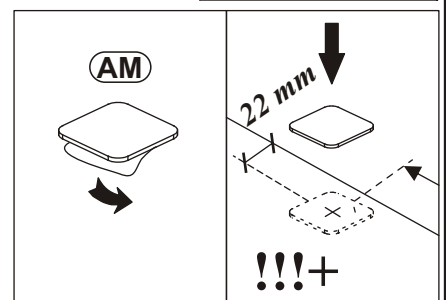
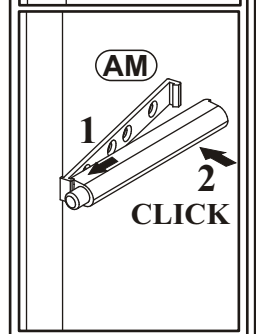
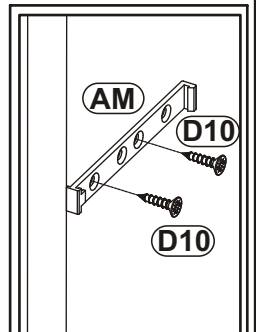
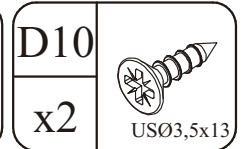
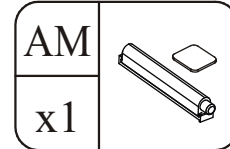
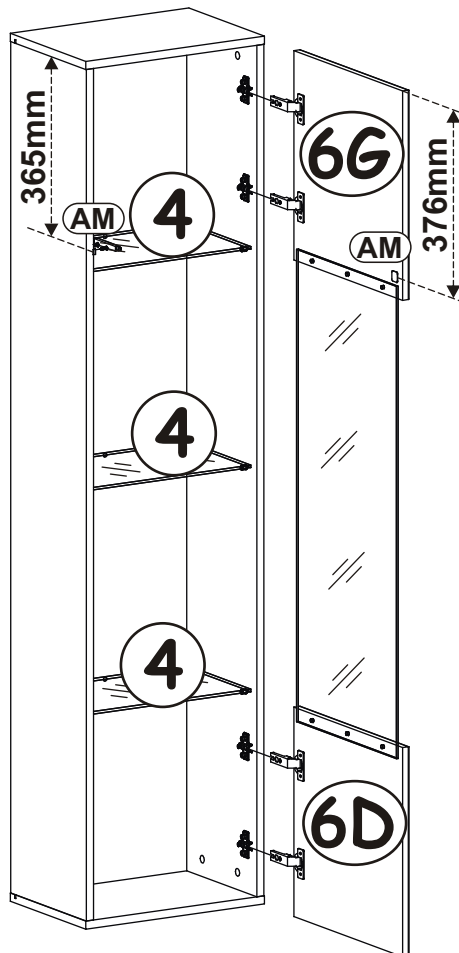
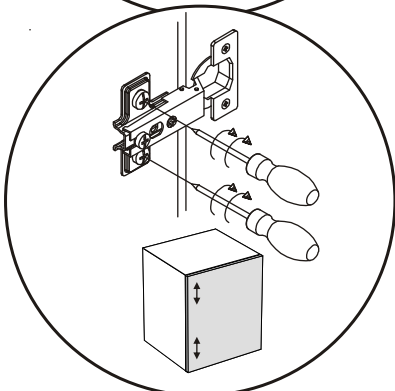
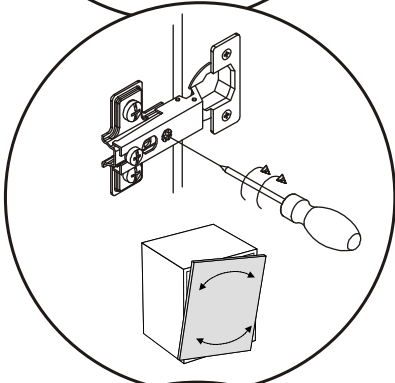
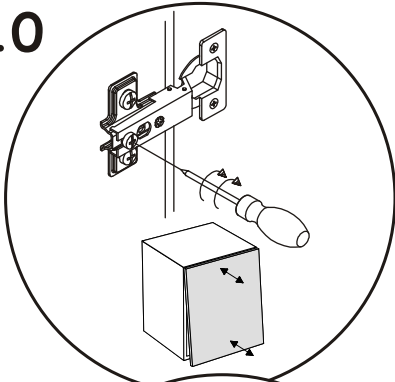

11

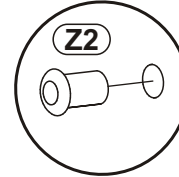
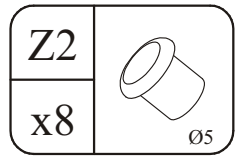
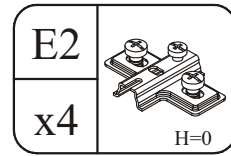
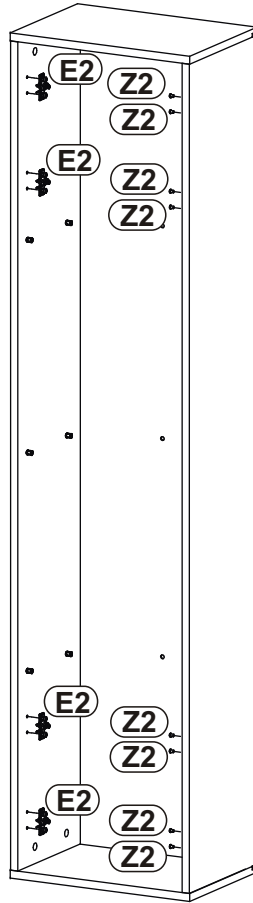
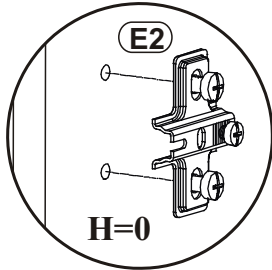
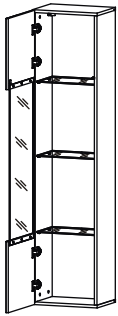

12

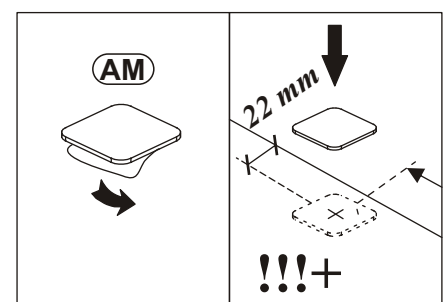
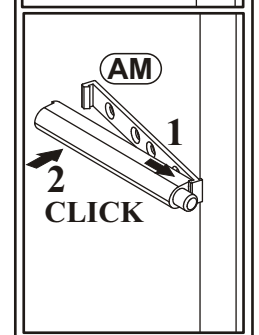
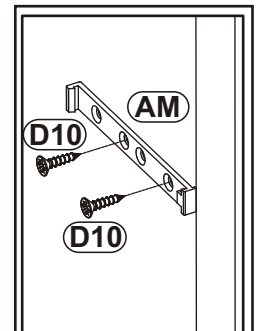
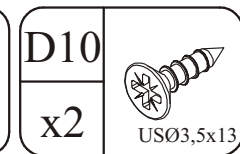
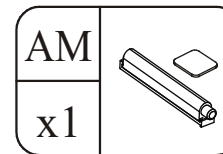
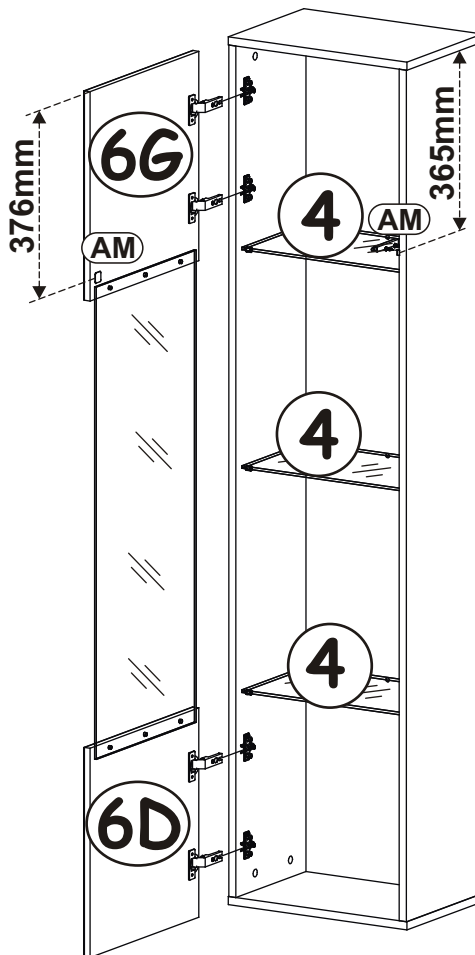
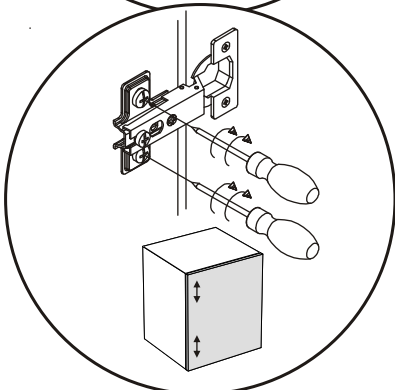
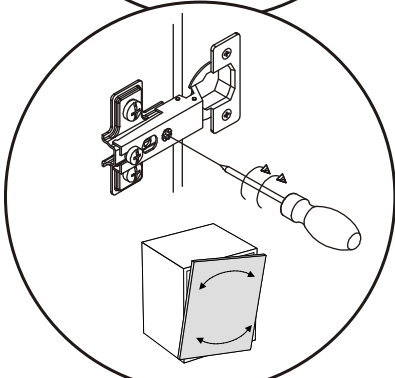
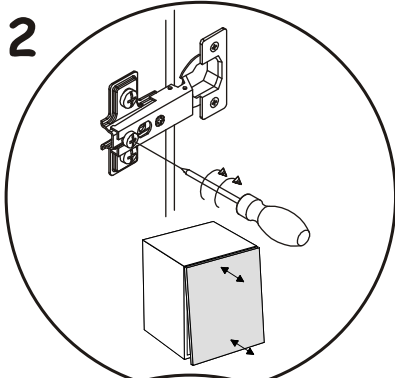

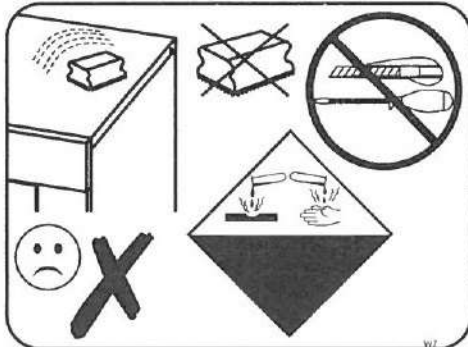
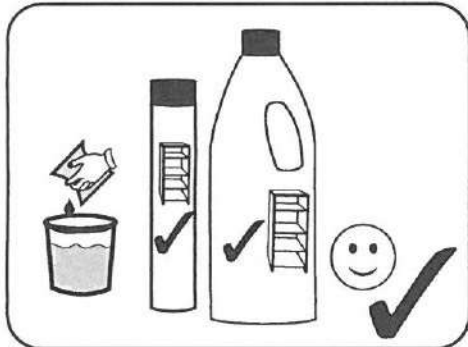
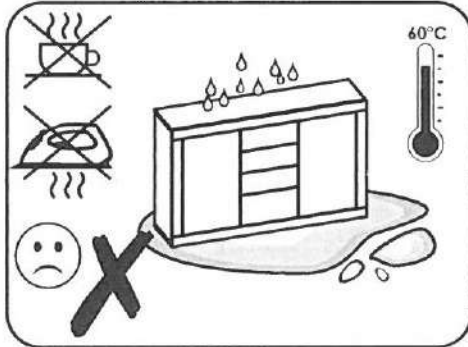
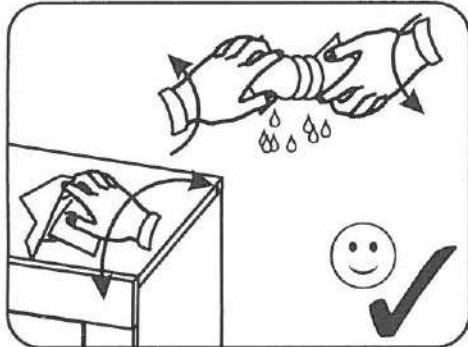
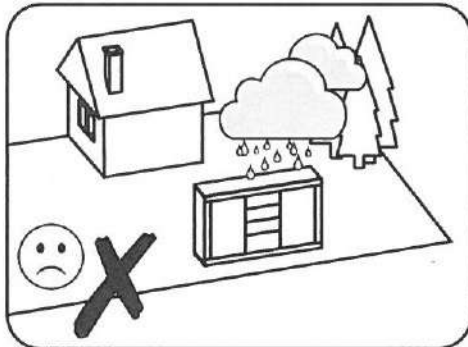
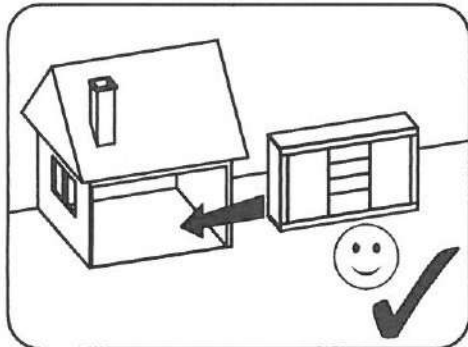

# FLY - PANEL 160

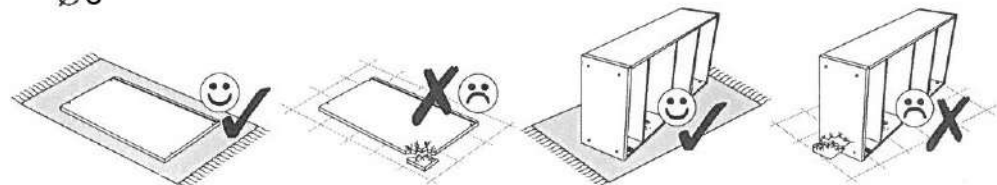
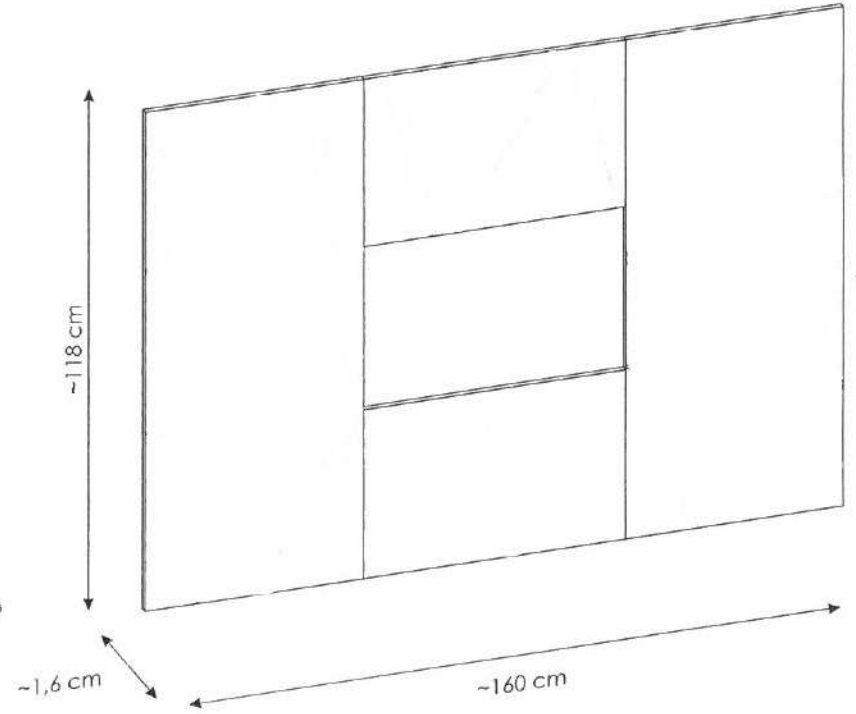
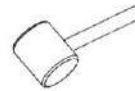
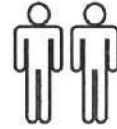

PL.

**UWAGA!** Mebel należy trwale zamocować do ściany, aby uniknąć ryzyka związanego z przewróceniem się mebla. W paczce znajdują się elementy mocujące odpowiednie wyłącznie do ścian betonowych lub z pełnej cegły. Jeśli Twoja ściana wykonana jest z innego materiału lub nie masz pewności co do budowy tej ściany, skonsultuj się w kwestii montażu ze specjalistą.

D.

**ACHTUNG!** Um alle mit dem Umkippen des Möbels verbundenen Risiken auszuschließen, muss das Möbel fest an der Wand verankert werden. Die im Paket enthaltenen Beschläge für die Wandbefestigung sind ausschließlich für Wände aus Beton oder Vollziegeln geeignet. Sollten die heimischen Wände aus anderem Baumaterial bestehen oder sollte es Zweifel in Hinsicht auf dieses Baumaterial geben, bitte eine Fachkraft zu Rate ziehen.

FR.

**ATTENTION!** Ce meuble doit être fixé en permanence au mur pour éviter les risques de chute. L'ensemble comprend des moyens de fixation adaptés uniquement aux murs de béton ou de brique. Si votre mur est fait d'un matériau différent ou si vous êtes incertain quant à la construction du mur, consultez un spécialiste.

I.

**ATTENZIONE!** Il mobile deve essere permanentemente fissato alla parete per evitare i rischi derivanti da un ribaltamento del mobile. La confezione contiene solo elementi di fissaggio adatti per pareti in calcestruzzo o in laterizio pieno. Se la vostra parete è realizzata in materiale diverso o avete dubbi sulla costruzione della parete, consultare uno specialista per un montaggio corretto.

EN.

**WARNING!** To prevent this furniture from tripping over, fix it to the wall permanently. The package includes fastening elements only suitable for concrete or full-brick walls. If your wall is made of a different material or you are unsure as to the construction of the wall, please consult a specialist regarding installation.

SK.

**POZOR!** Nábytok musí byť trvalo pripevnený k stene tak, aby sa zamedzilo riziku prevrátenia. V balíku sa nachádzajú upevňovacie komponenty výlučne pre betónové steny alebo steny z plnej tehly. Ak je Vaša stena z iného materiálu alebo ak si nie ste istí, z čoho je stena vyhotovená, vyžiadajte si odbornú pomoc.

CZ.

**POZOR!** Nábytek je nutné pevně připevnit ke zdi, abychom se vyhnuli riziku spojenému s jeho převrnutím. V balíčku se nacházejí připevňující prvky vhodné výhradně do betonových zdí nebo zdí z plných cihel. Pokud jsou Vaše zdi zhotoveny z jiného materiálu nebo si nejste jejich konstrukcí jisti, konzultujte otázku montáže se specialistou.

RU.

**ПРИМЕЧАНИЕ!** Эту мебель необходимо всегда прикреплять к стене, чтобы избежать рисков, связанных с переворотом мебели. В пакете находятся крепежные элементы, которые подходят исключительно к бетонным стенам или из целого кирпича. Если стена изготовлена из другого материала или вы не уверены относительно строения стены, проконсультируйтесь относительно монтажа со специалистом.

3 ▶

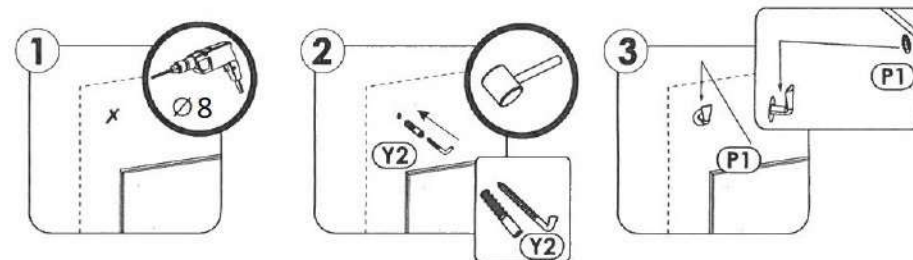
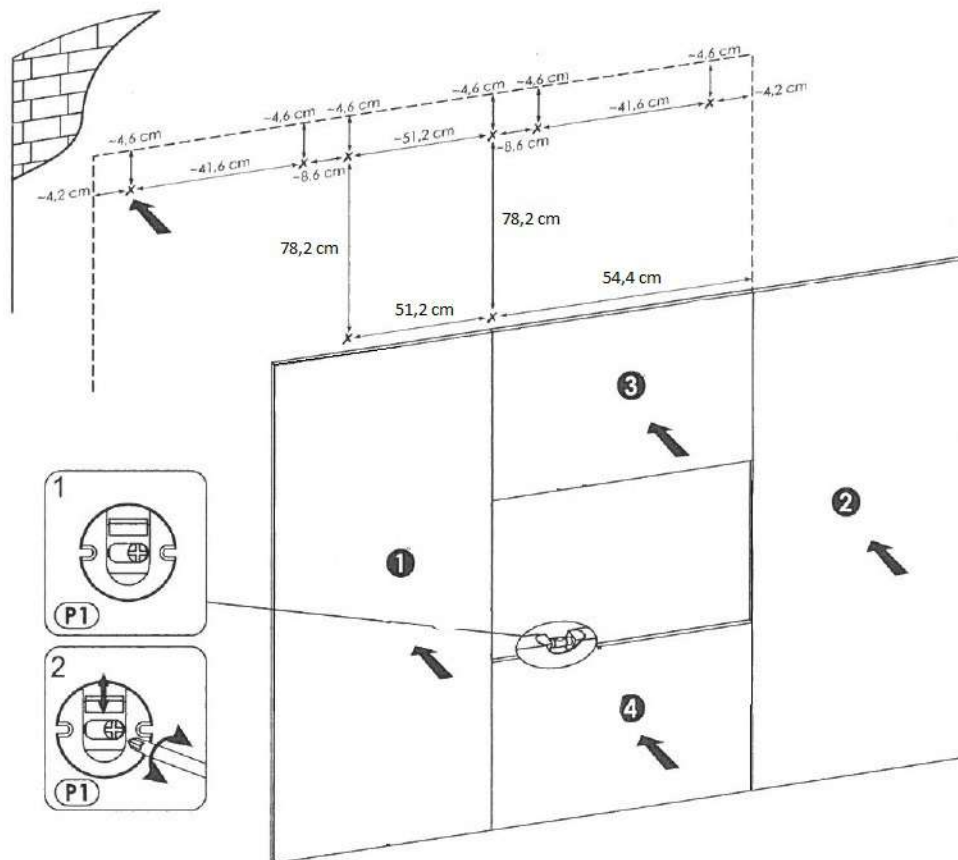

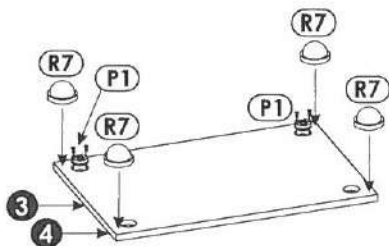
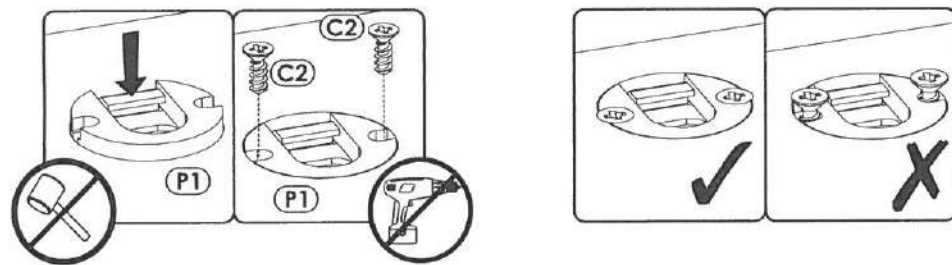
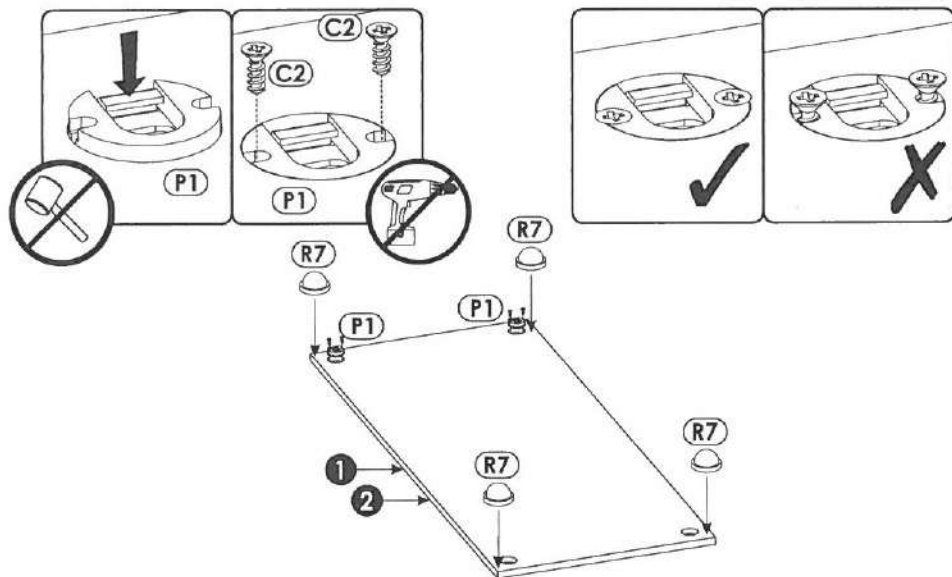

RO.  
**ATENȚIE!** Mobila trebuie ancorată permanent în perete pentru a evita riscul de răsturnare a mobilei. Pachetul conține elementele de fixare potrivite numai pentru pereții din beton sau din cărămidă solidă. Dacă peretele Dvs. este realizat dintr-un alt material sau nu sunteți sigur care este structura peretelui, consultați un specialist în privința montajului.

NL.  
**OPMERKING!** De meubelen moeten permanent aan de muur worden bevestigd om te voorkomen dat de meubelen kantelen. Het pakket bevat bevestigingselementen die alleen geschikt zijn voor betonnen of massieve bakstenen muren. Als uw muur van een ander materiaal is gemaakt of als u niet zeker bent over de constructie van deze muur, raadpleeg dan een specialist voor de installatie.

TR.  
**DİKKAT!** Devrilme riskini önlemek için mobilya duvara sabitlenmelidir. Pakette, sadece beton veya tam tuğla duvarlara uygun sabitleme elemanları bulunmaktadır. Eğer duvarınız başka bir malzemedir yapıldıysa veya duvar yapısından emin değilseniz, montaj konusunda bir uzmana danışınız.

SLO.  
**POZOR!** Pohišivo trajno pritrđite na steno, da preprečite tvganje, da se prevrne. V paketu so pritrđilni elementi, ki so ustrezni izključno za betonske stene in za stene iz polne opeke. Če je vaša stena izdelana iz drugih materialov ali niste gotovi glede konstrukcije stene, se o montaži posvetujte s strokovnjakom.

HU.  
**FIGYELEM!** Rőgzítse a bútorokat a falhoz, hogy elkerülje a bútor felborulásának kockázatát. A készletben kizárólag beton- vagy téglafalhoz használható kötőelemek találhatók. Ha a fal más anyagból készült, vagy ha nem tudja, milyen falak találhatók otthonában, forduljon szakemberhez.

AR.  
**ملاحظة!**

يجب تثبيت الأثاث بإحكام إلى الحائط أو الجدار لتجنب خطر إنقلابه. تحتوي العلبة على مسامير التثبيت التي تناسب الجدران الخرسانية أو الطوب. إذا كان جدارك مصنوعاً من مادة مختلفة أو لم تكن متأكداً من مادة بناءه اسأل المتخصص عن كيفية التثبيت.



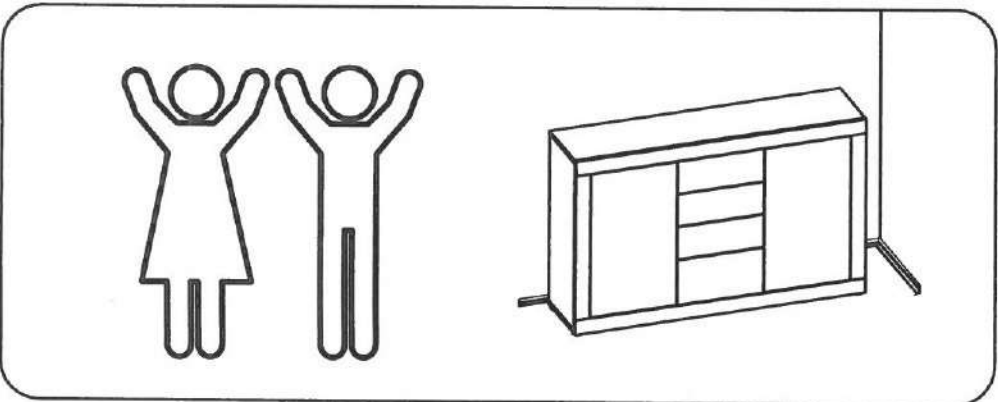
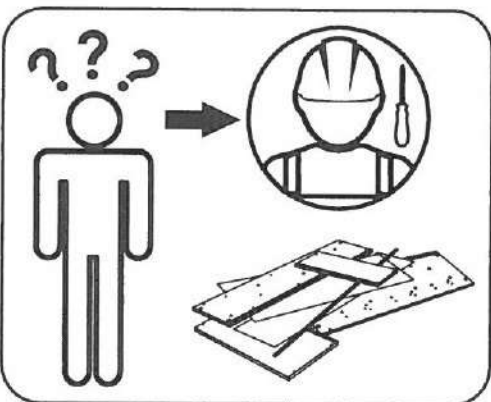
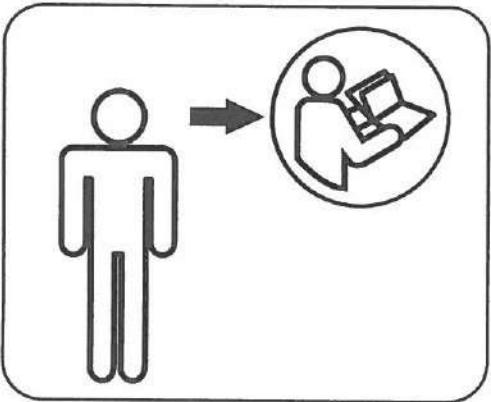
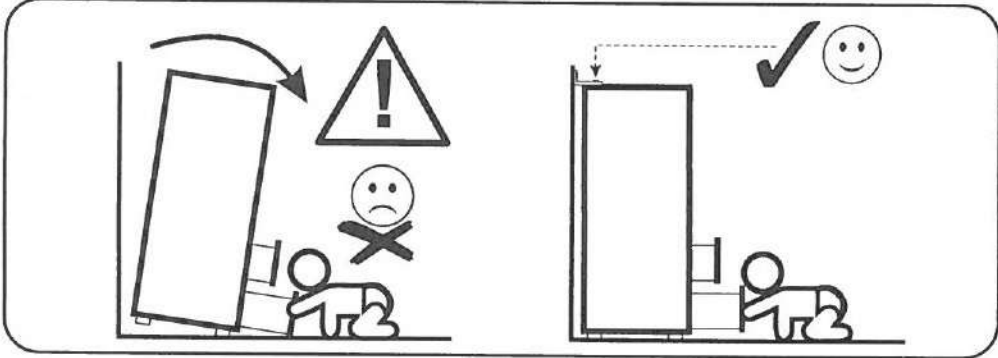
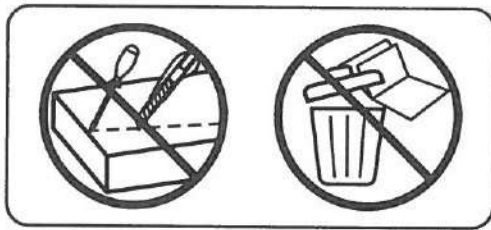
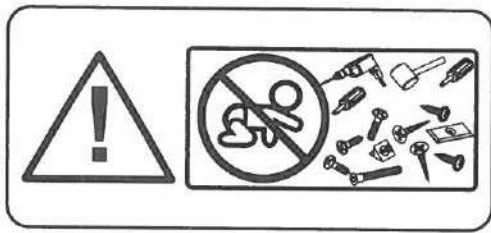

E.  
**¡ATENCIÓN!** El mueble debe ser fijado permanentemente a la pared para evitar el riesgo relacionado con el vuelco del mueble. En el paquete hay elementos de fijación adecuados solo para paredes de hormigón o de ladrillo entero. Si su pared está hecha de otro material o no está seguro sobre la construcción de esta pared, consulte el montaje con un especialista.

CN.  
**注意!** 本家具需要固定在墙上以免倒塌。本包所含有的固定部件仅适用于混凝土墙及整砖墙。欲使用在其他墙体或不确定墙体时，请向专家询问安装方式。

HR.  
**NAPOMENA!** Namještaj mora biti trajno pričvršćen za zid, kako bi se izbjegao rizik od njegova prevrnuća. U paketu se nalaze elementi za pričvršćivanje prikladni isključivo za betonske zidove ili punu ciglu. Ako je Vaš zid izrađen od drugog materijala ili niste sigurni od čega je napravljen Vaš zid, konzultirajte se sa stručnjakom u vezi sa montažom.



# FLY - PANEL 160

<b>(C2)</b> 5 x 13 mm x16 	<b>(P1)</b>  x8	<b>(R7)</b>  x16
<b>(Y2)</b>  x8 Ø8		

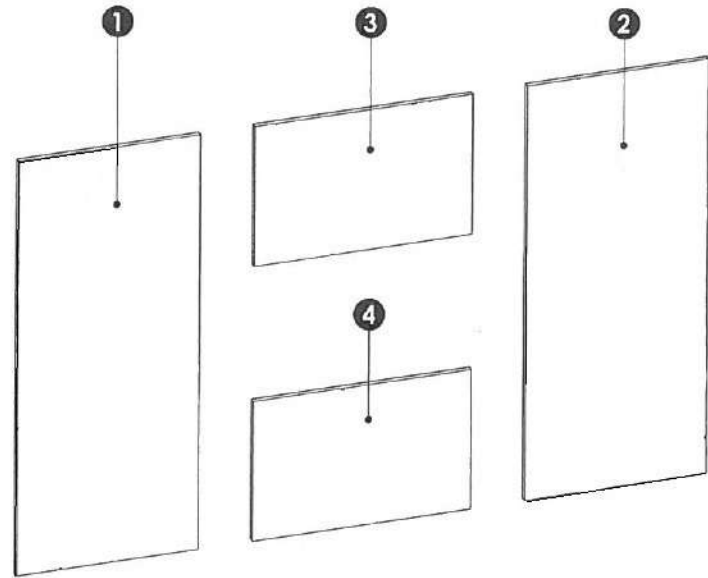

<b>1</b>	1180	500	16	x1	1/1
<b>2</b>	1180	500	16	x1	1/1
<b>3</b>	398	600	16	x1	1/1
<b>4</b>	398	600	16	x1	1/1





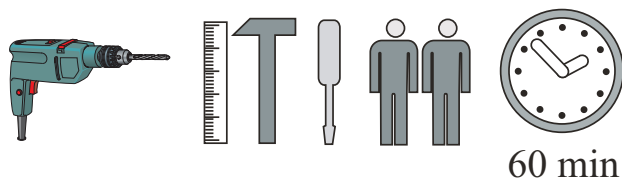
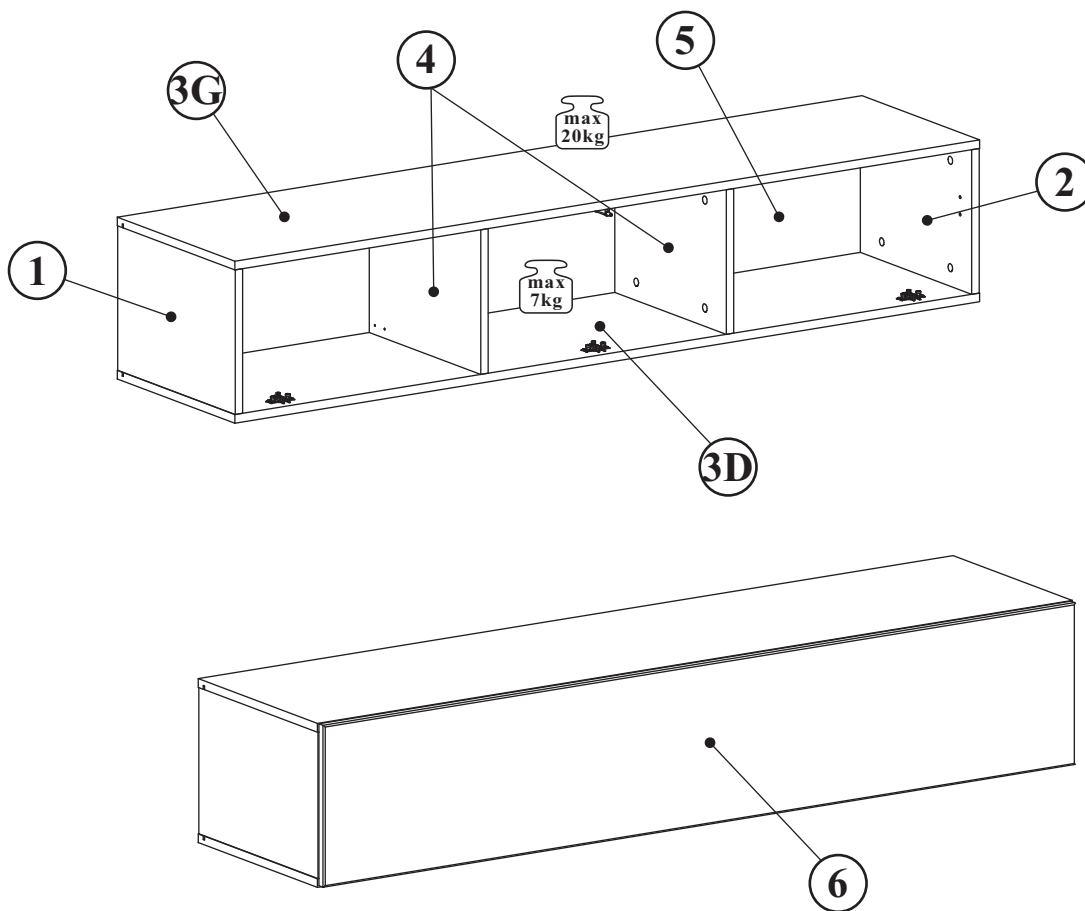
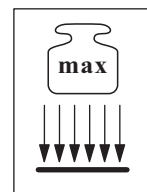



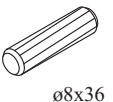
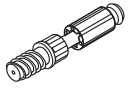

# FLY TYP-30

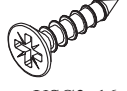

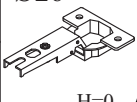
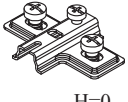
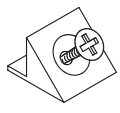
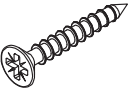
NO	Dim.			Col.-No	Qty
1	268	384	16	1	1
2	268	384	16	1	1
3D/G	1602	384	16	1	2
4	268	364	16	1	2
5	1580	280	3	1	1
6	1596	296	16	1	1

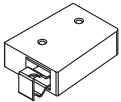
# FLY TYP-30

A1 x16  ø8x36	B4 x16 	B5 x16  ø15x12	G5 x16 	D7 x6  USØ3x16	G2 x1 
E1 x3 Ø26 H=0 	E2 x3 H=0 	S1 x12 	D6 x8 USØ3,5x30 	D10 x12 USØ3,5x13 	G21 x2 
ZR1 x4 	KR2 x4 	T1 x1 			

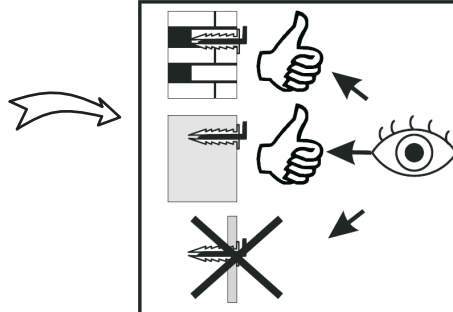
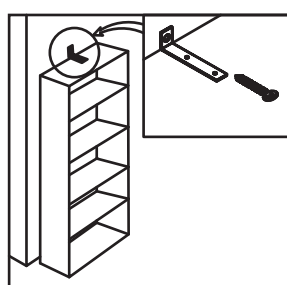
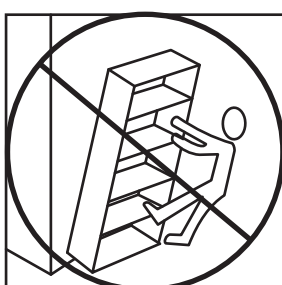
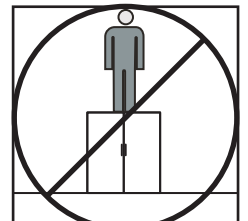
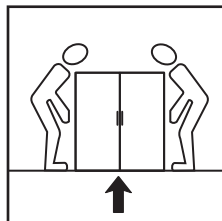
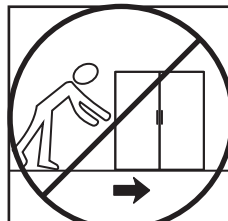
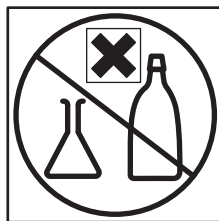
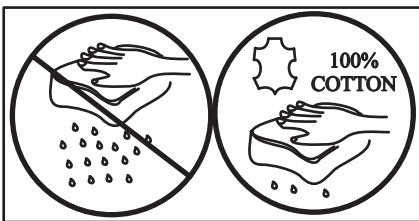
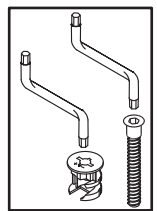
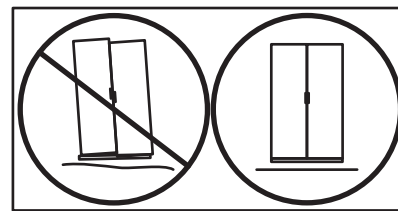
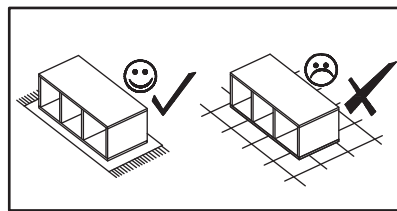
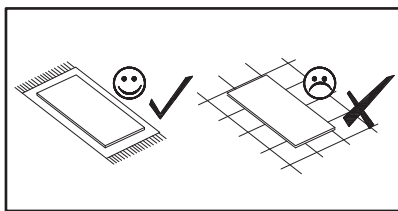
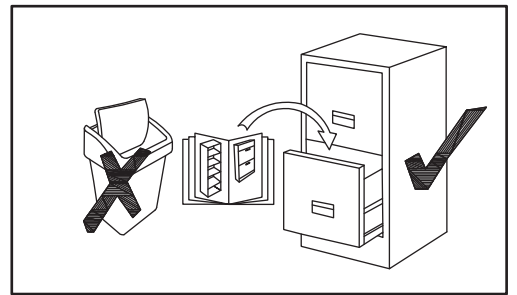
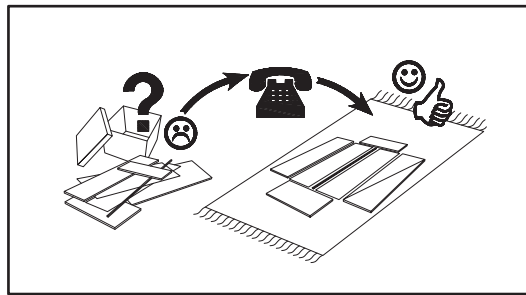
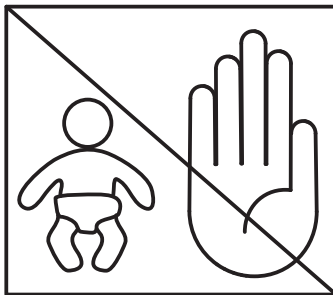
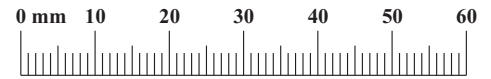

# FLY TYP-30

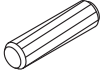
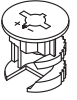
A1		B5	
x16	ø8x36	x16	ø15x12

## 1

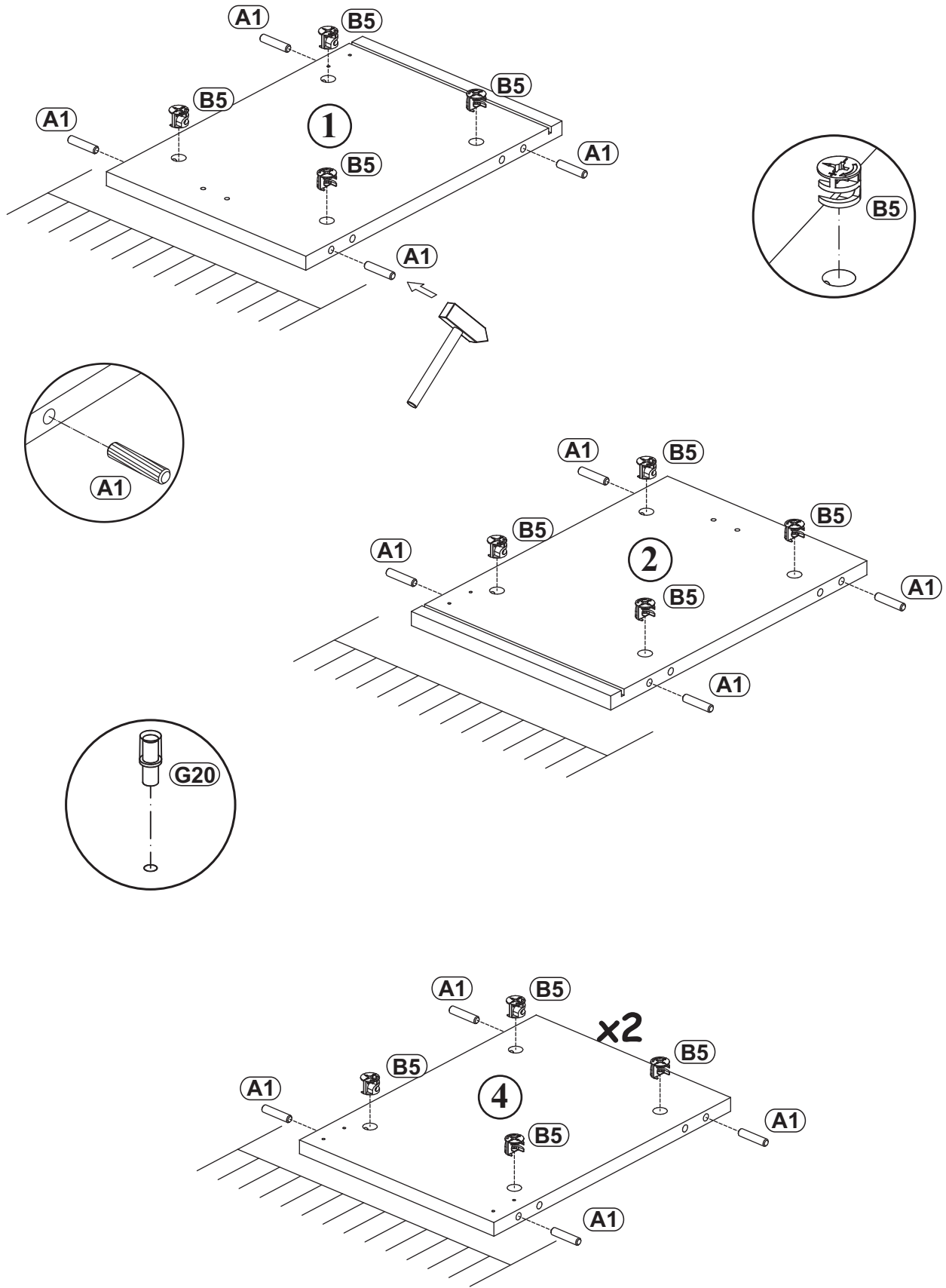

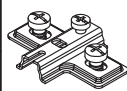
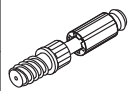

FLY TYP-30

2

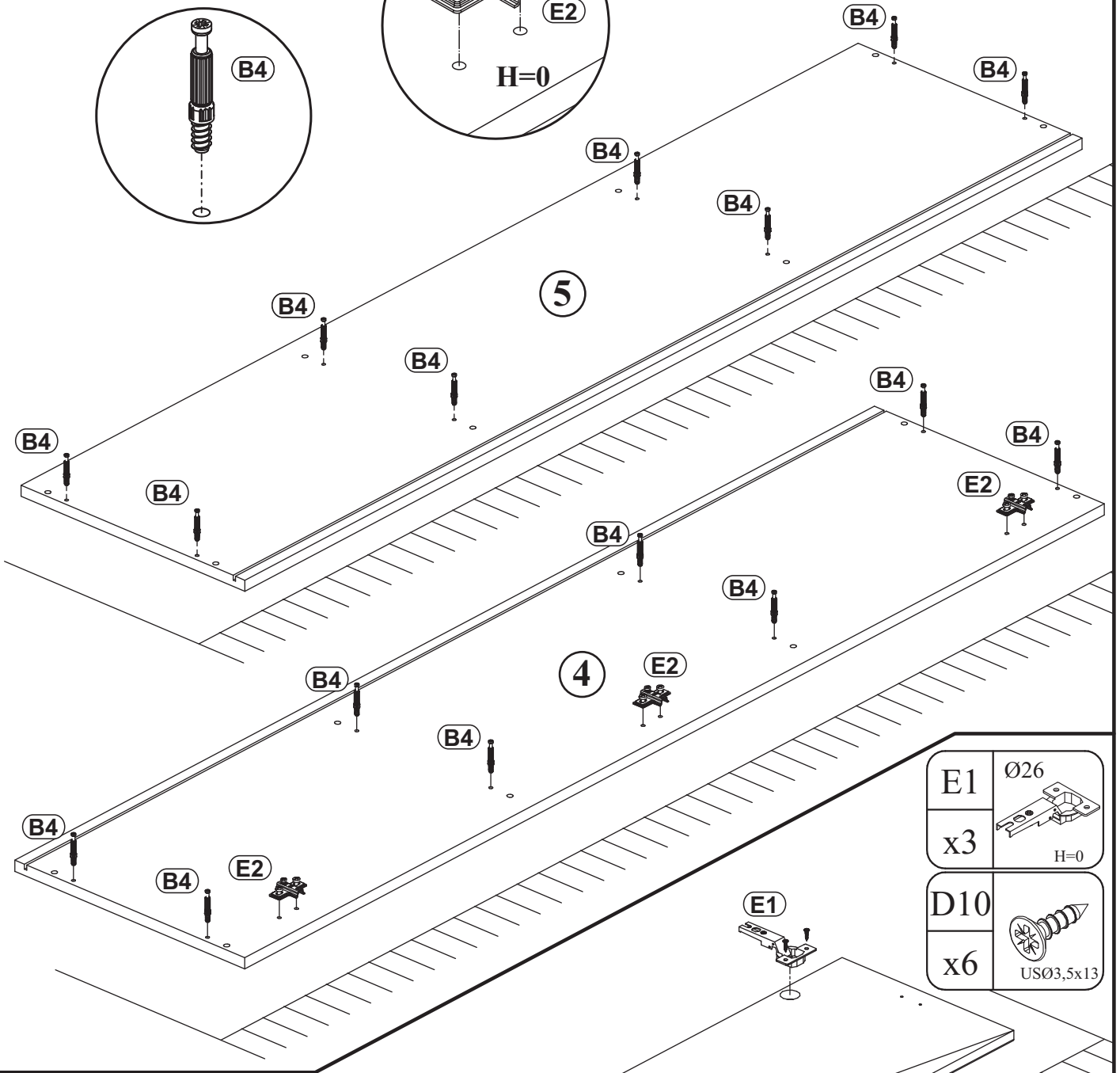
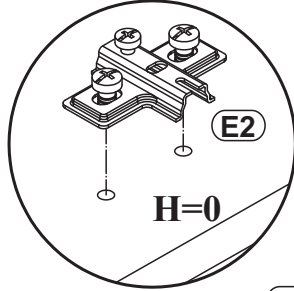
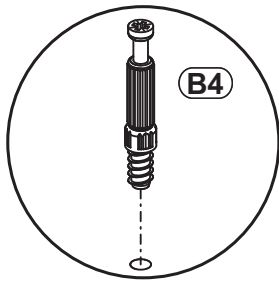
E2		B4	
x3	H=0	x16	

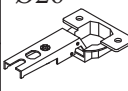

3

E1	Ø26	
x3	H=0	
D10		
x6	USØ3,5x13	

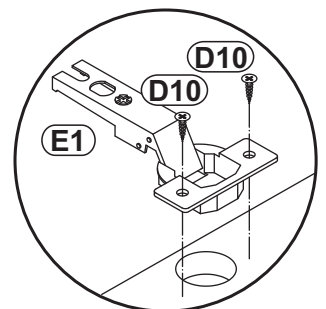
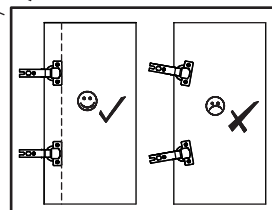
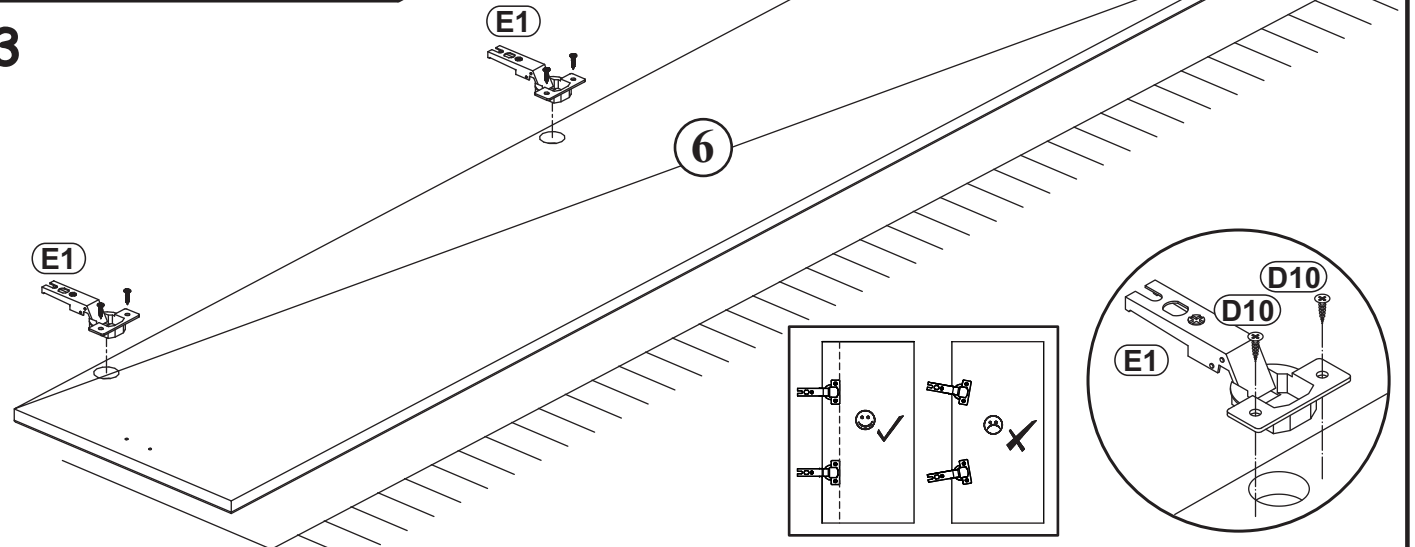

G5	
x16	

4

a)

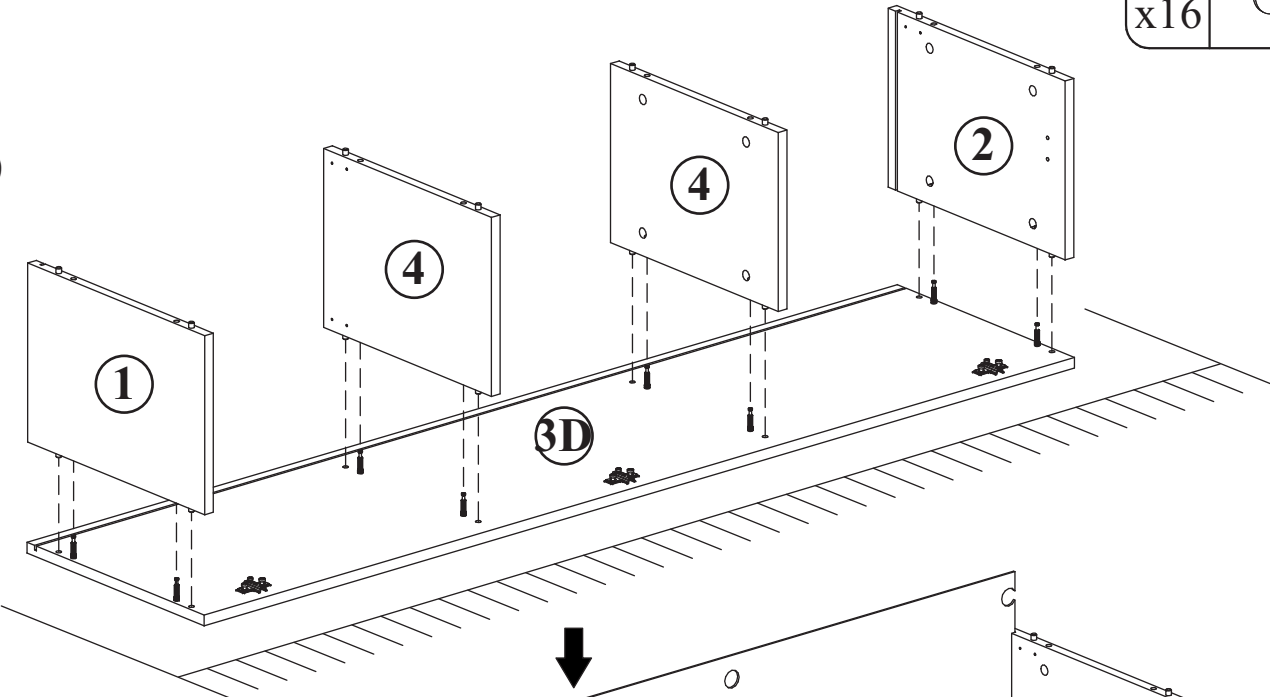

b)

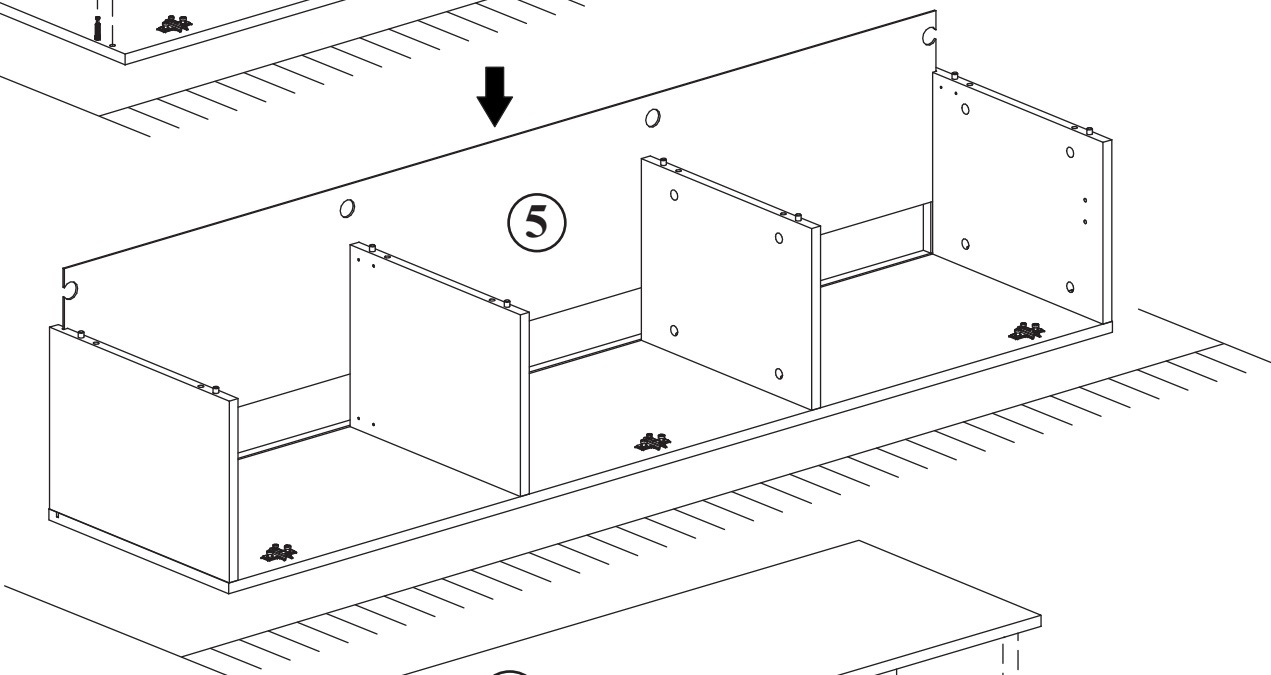

c)

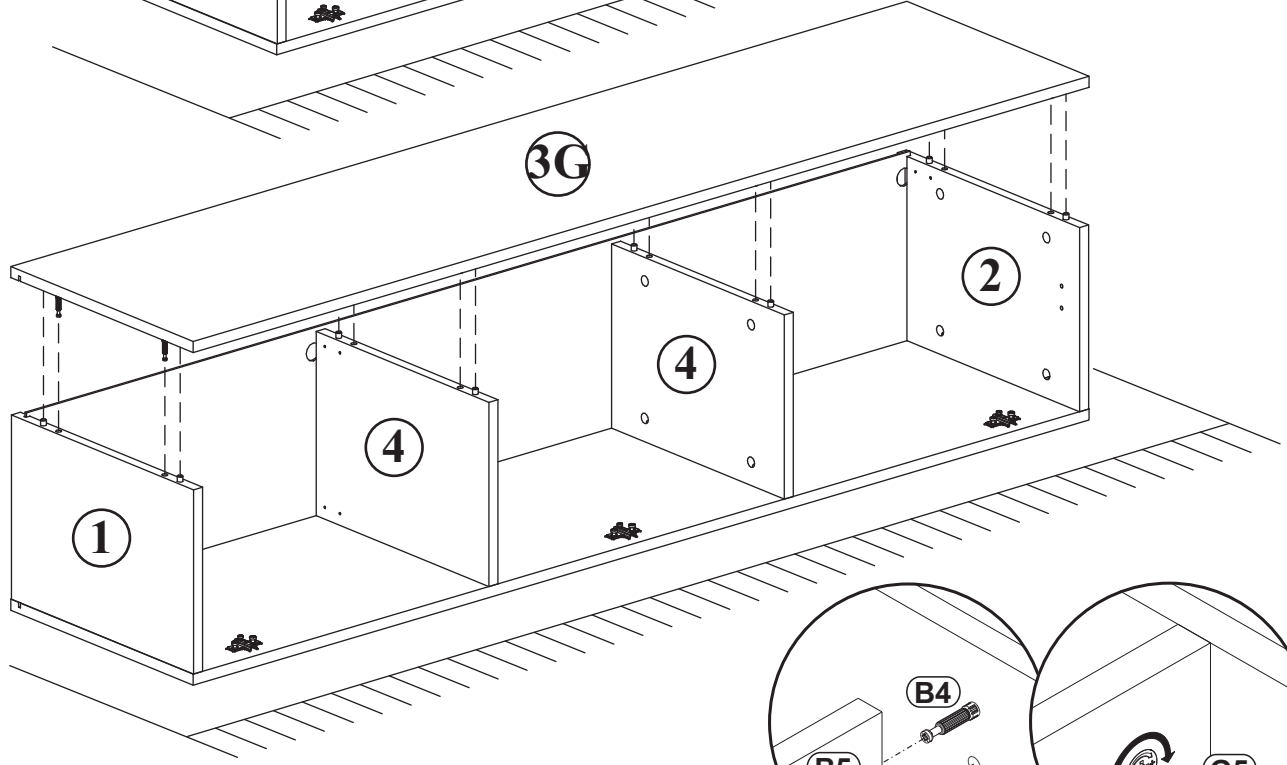

B4

B5

G5

FLY TYP-30

5

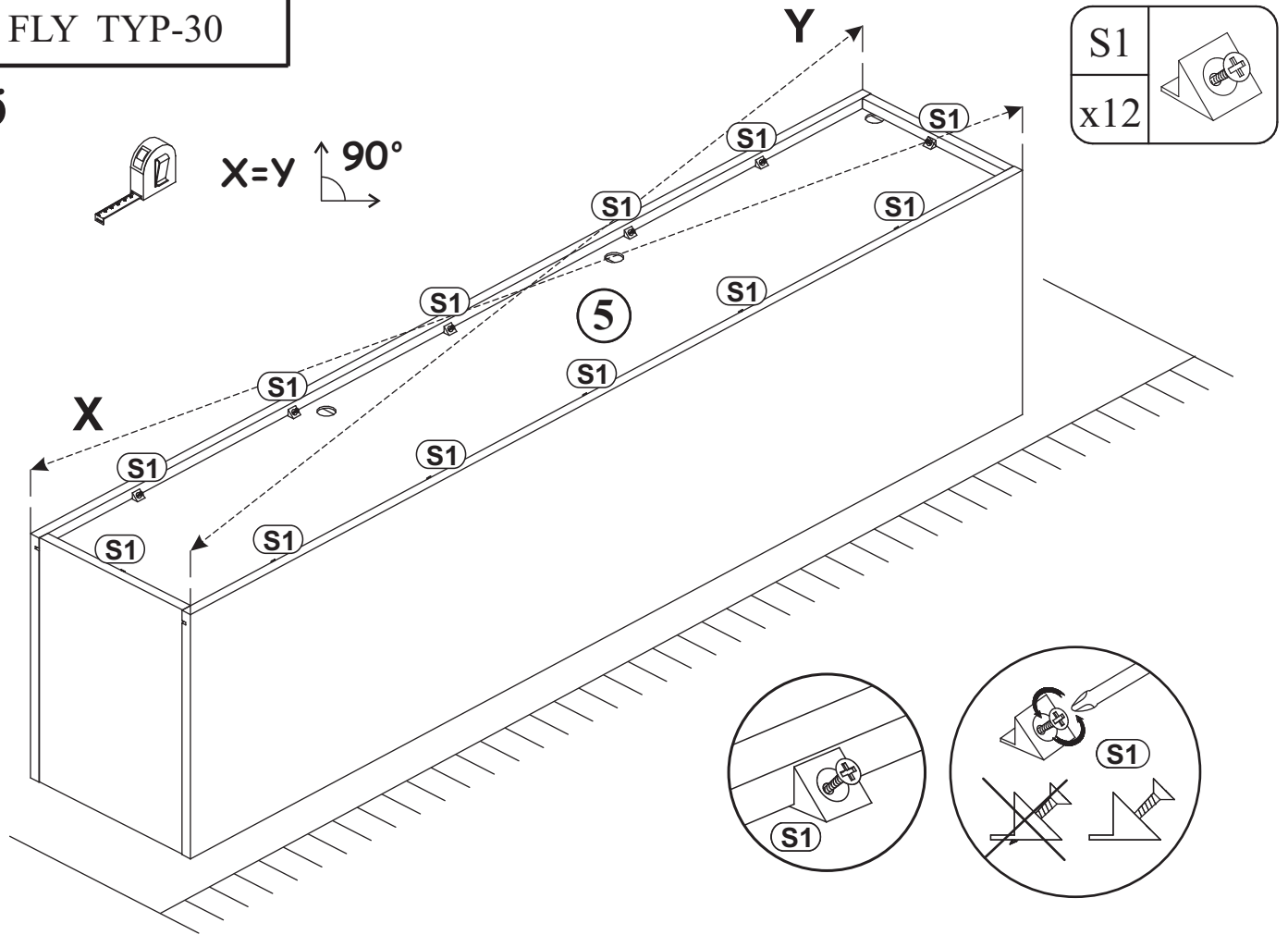

S1	
x12	

6

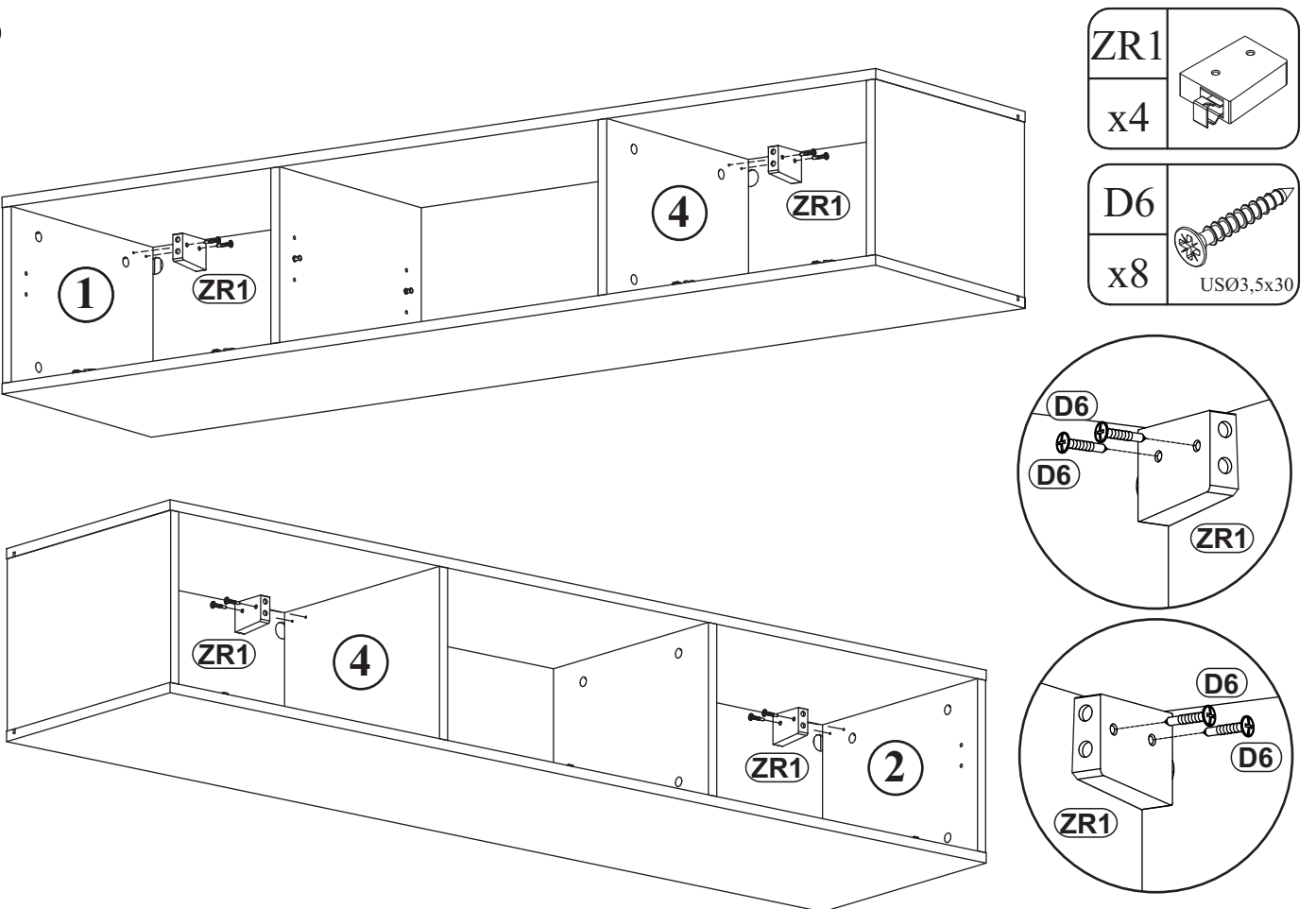

ZR1	
x4	

D6	
x8	USØ3,5x30

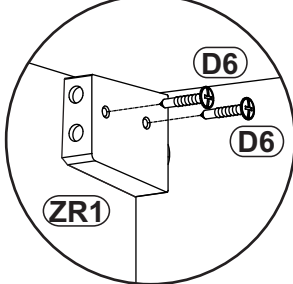
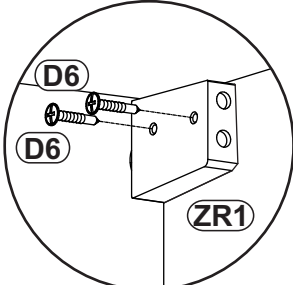

# FLY TYP-30

7

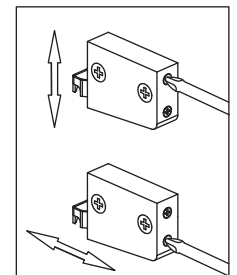
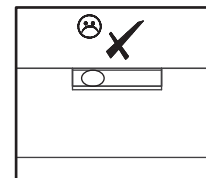
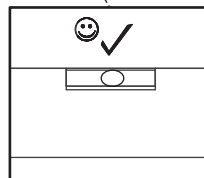
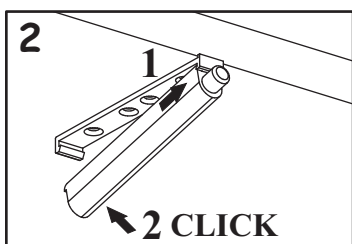
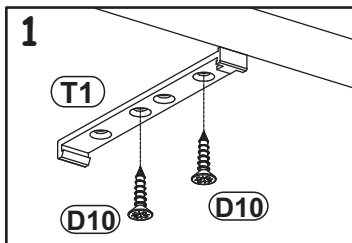
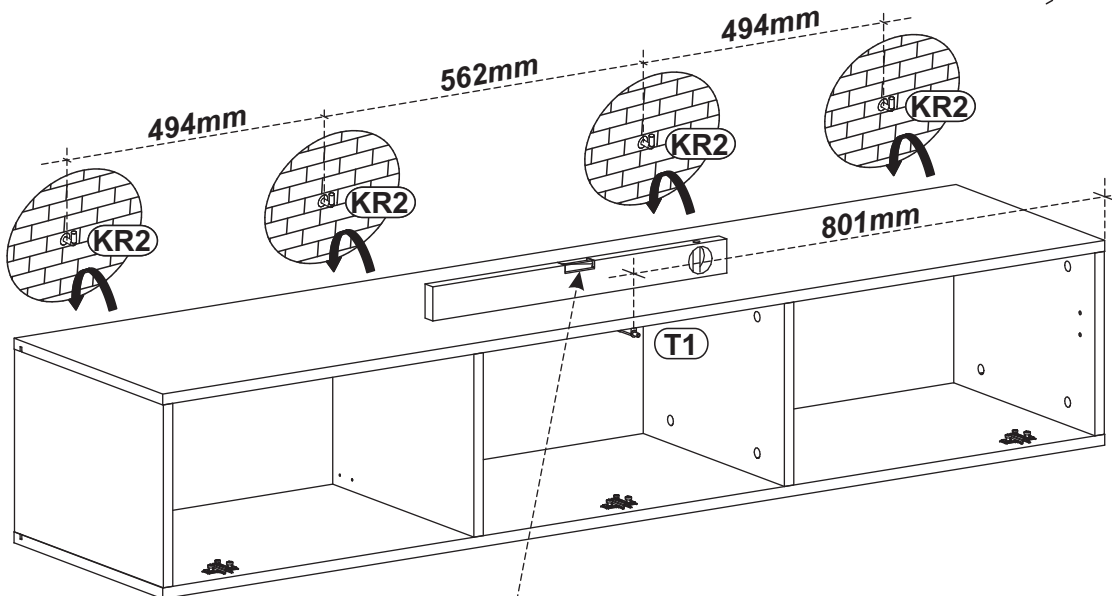
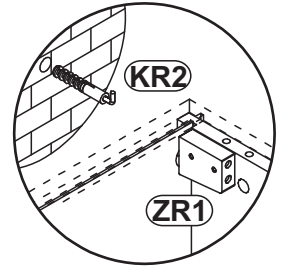
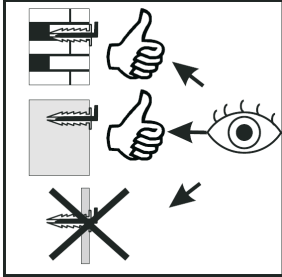
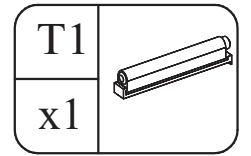
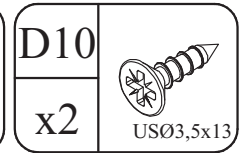
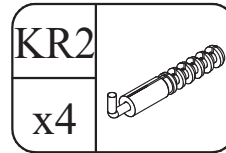
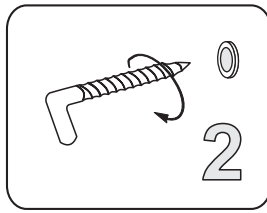
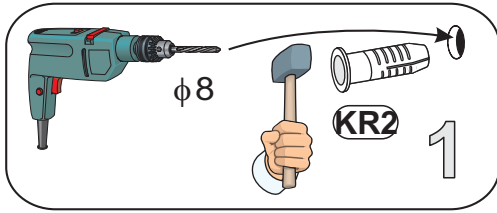

8

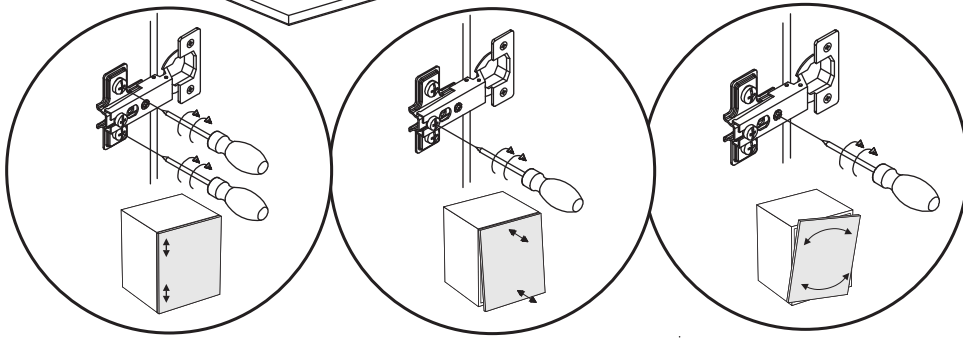
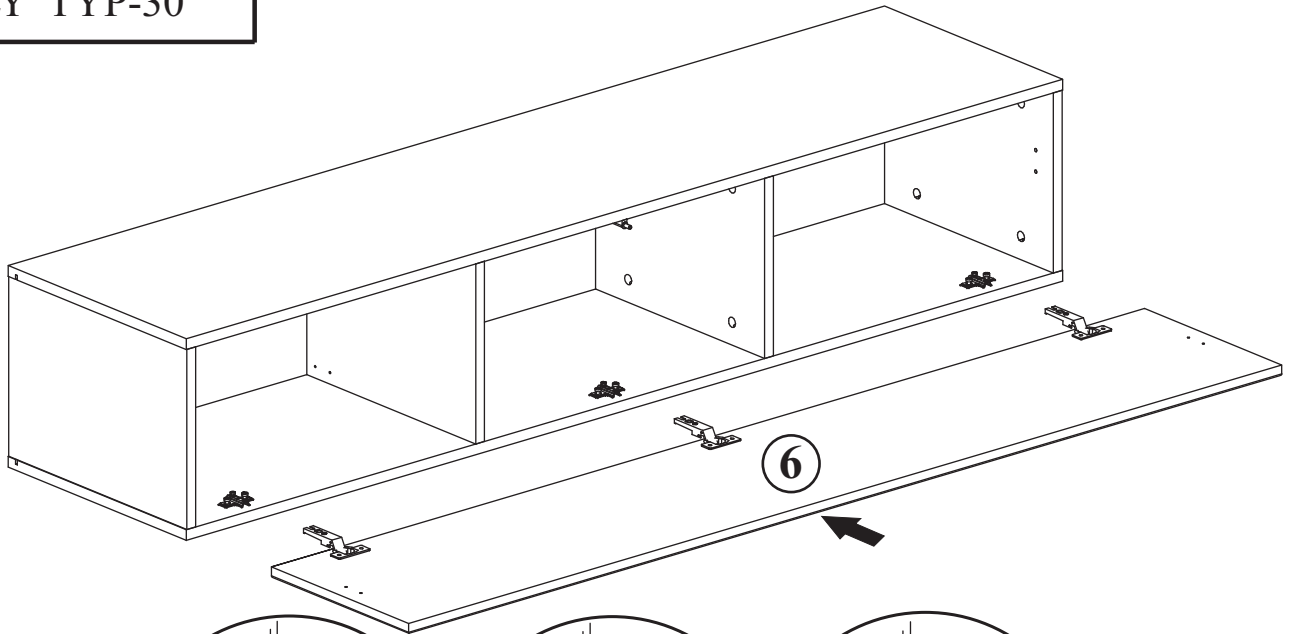

9

